

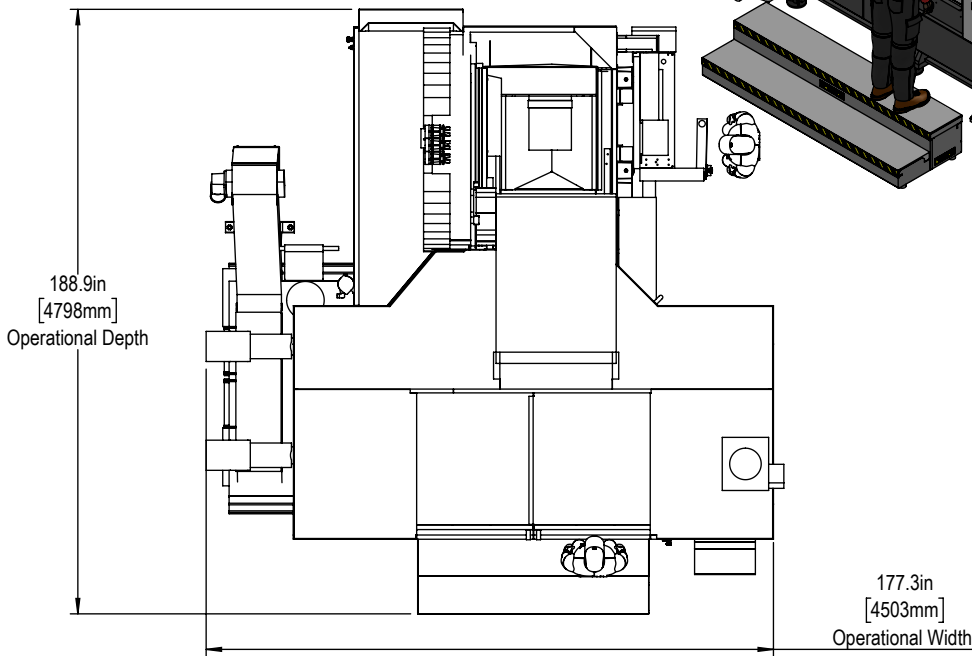

Installed Dimensions

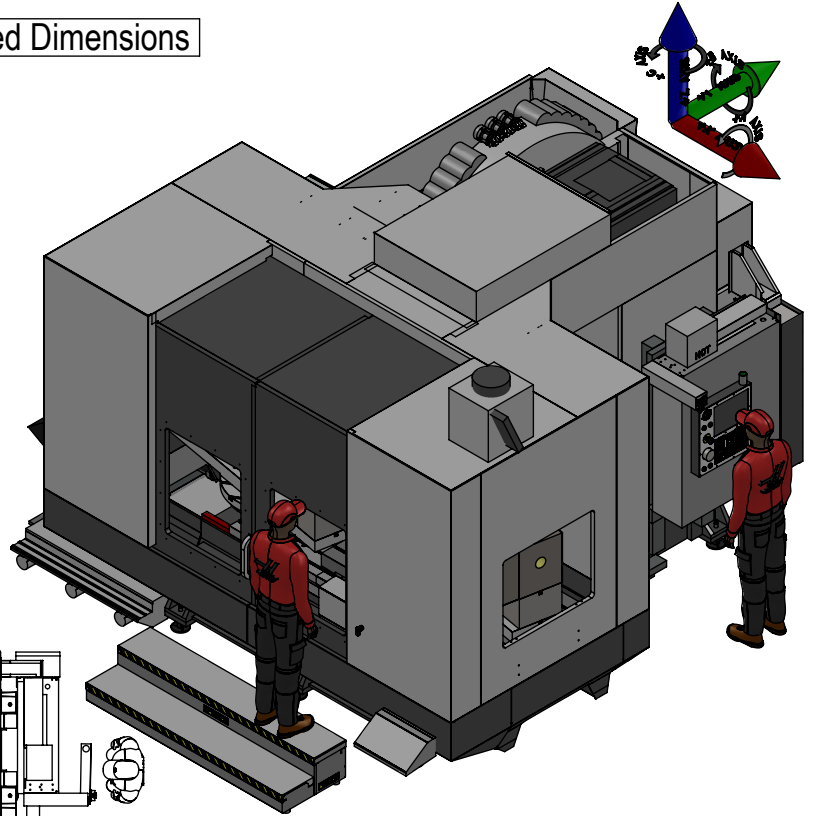

Leveling Pad Height

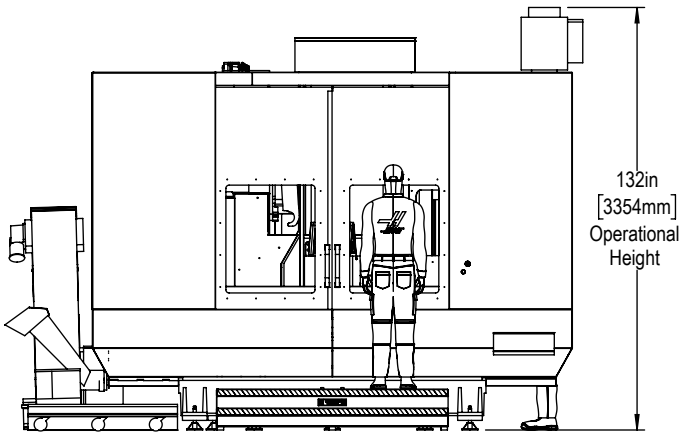
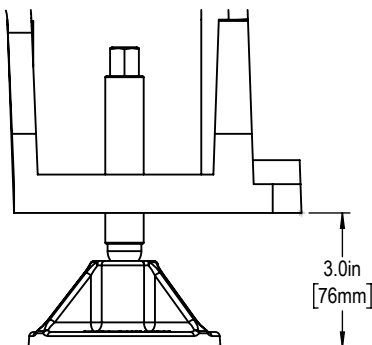

Shipping Dimensions

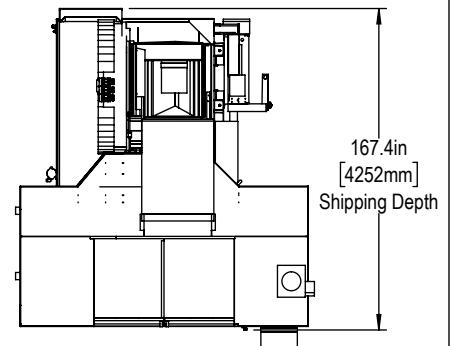
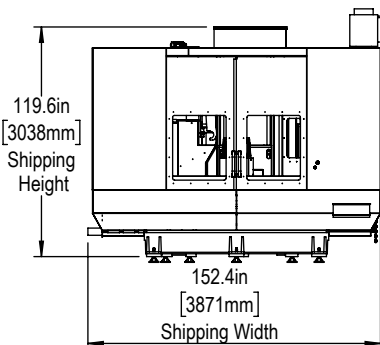

\*All Height Dimensions Based on Suggested Leveling Pad Height

Air & Power

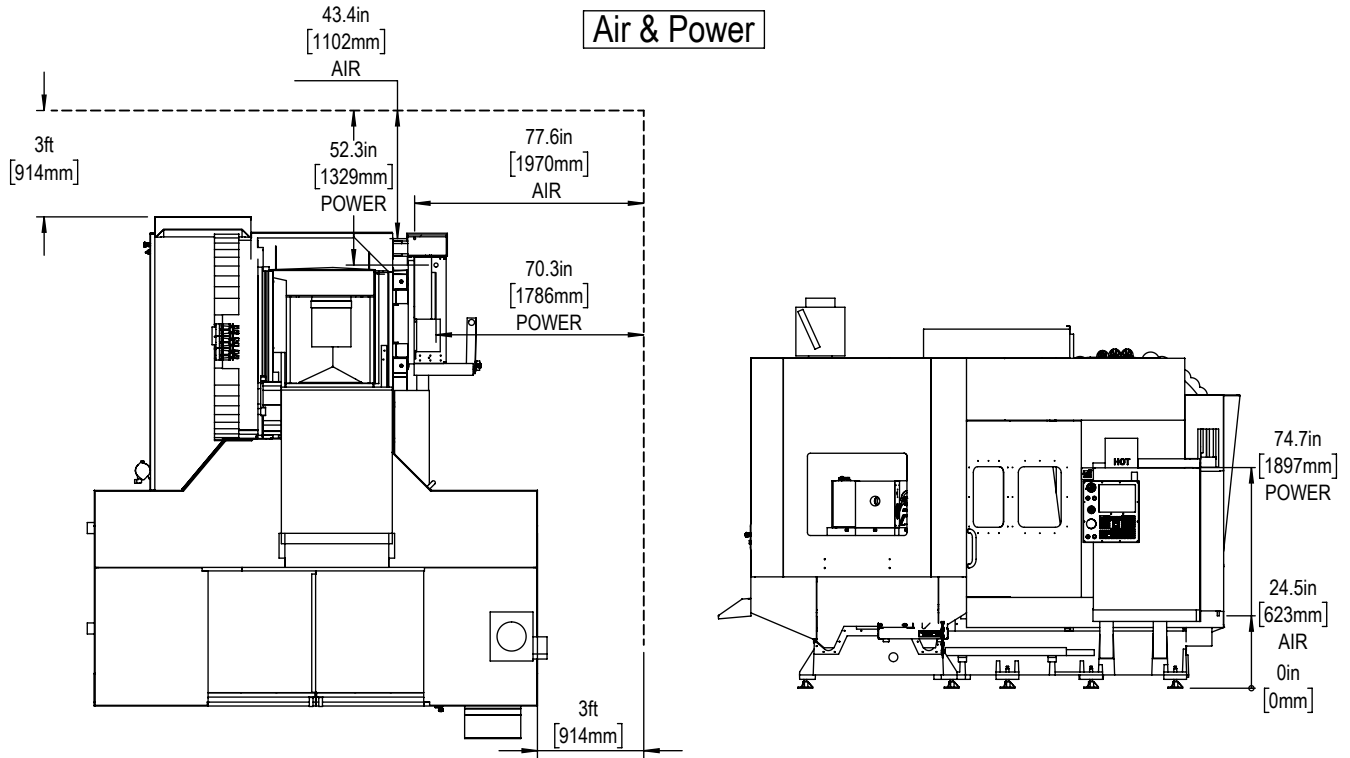

Anchor Pattern

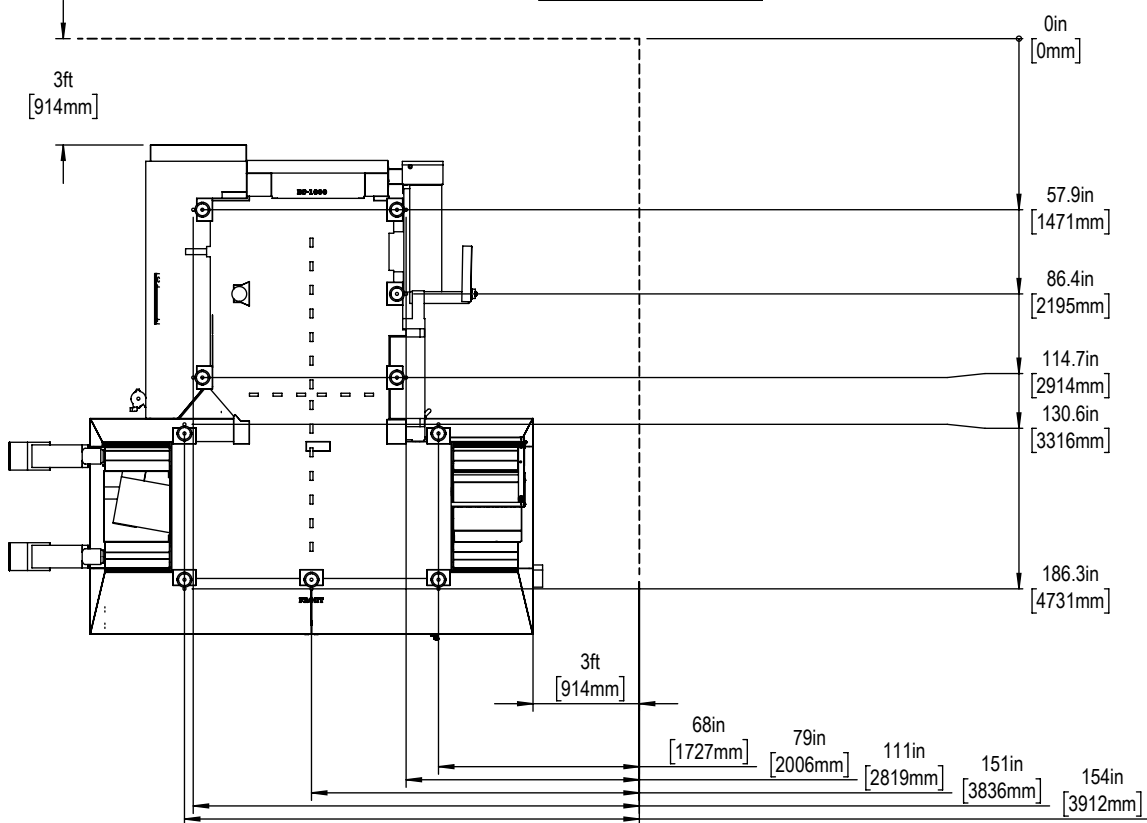

For precise locations please use template in Anchoring Kit found at Haascnc.com



Height Breakdown

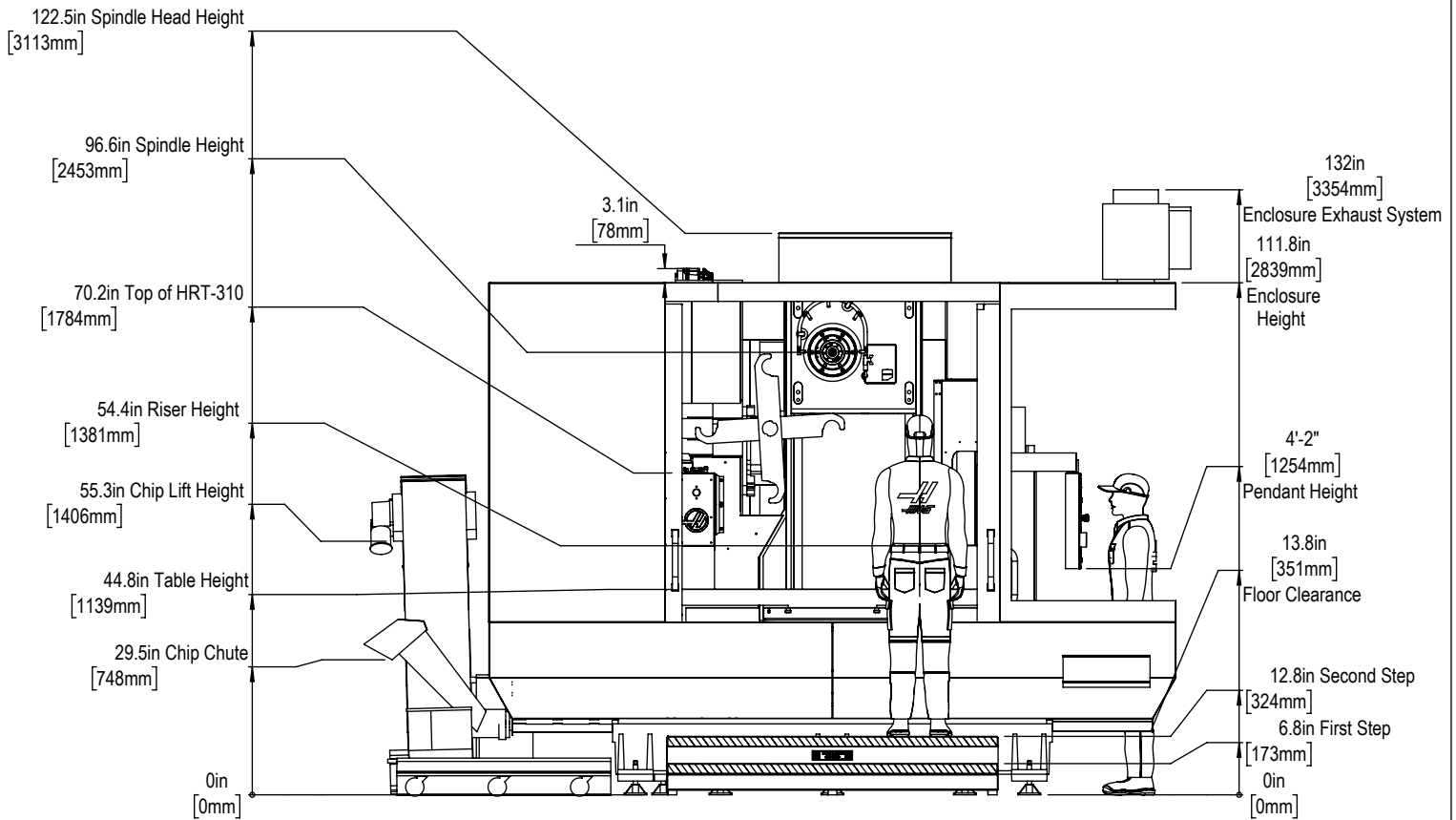

Width Breakdown

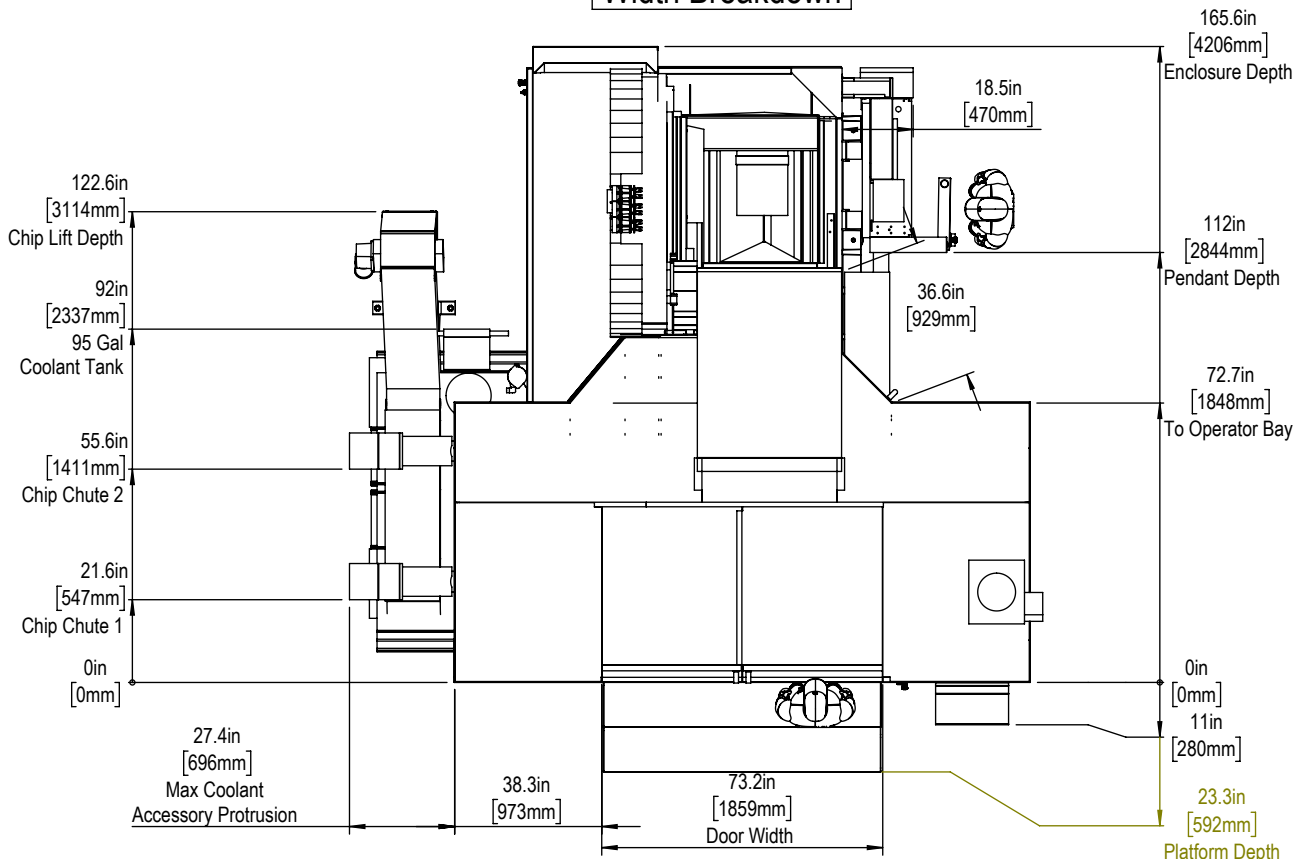

Maintain 3 feet [915mm] clearance to the nearest obstruction around all sides of machine perimeter for maintenance access



Max Part Swings

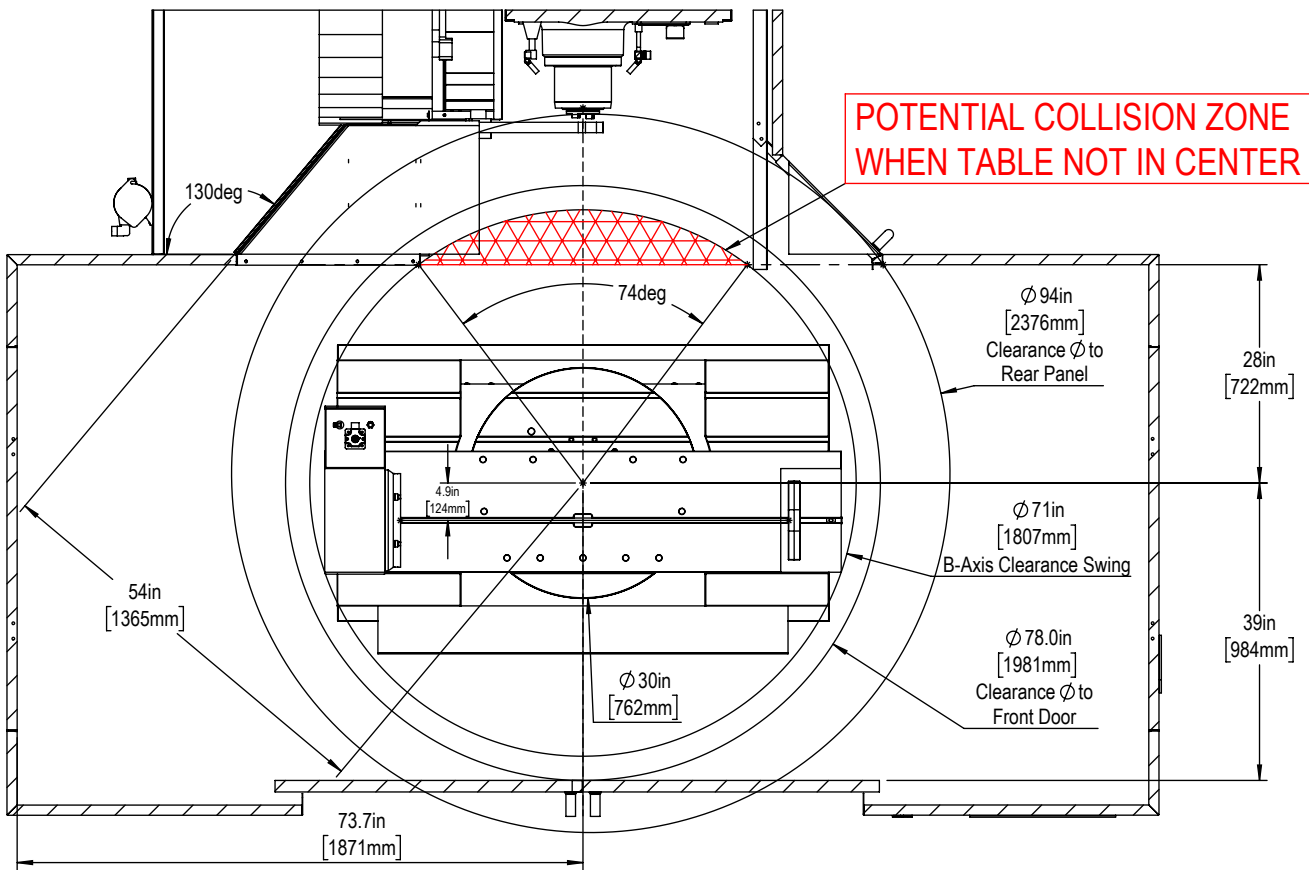

B-Axis Collision Zones

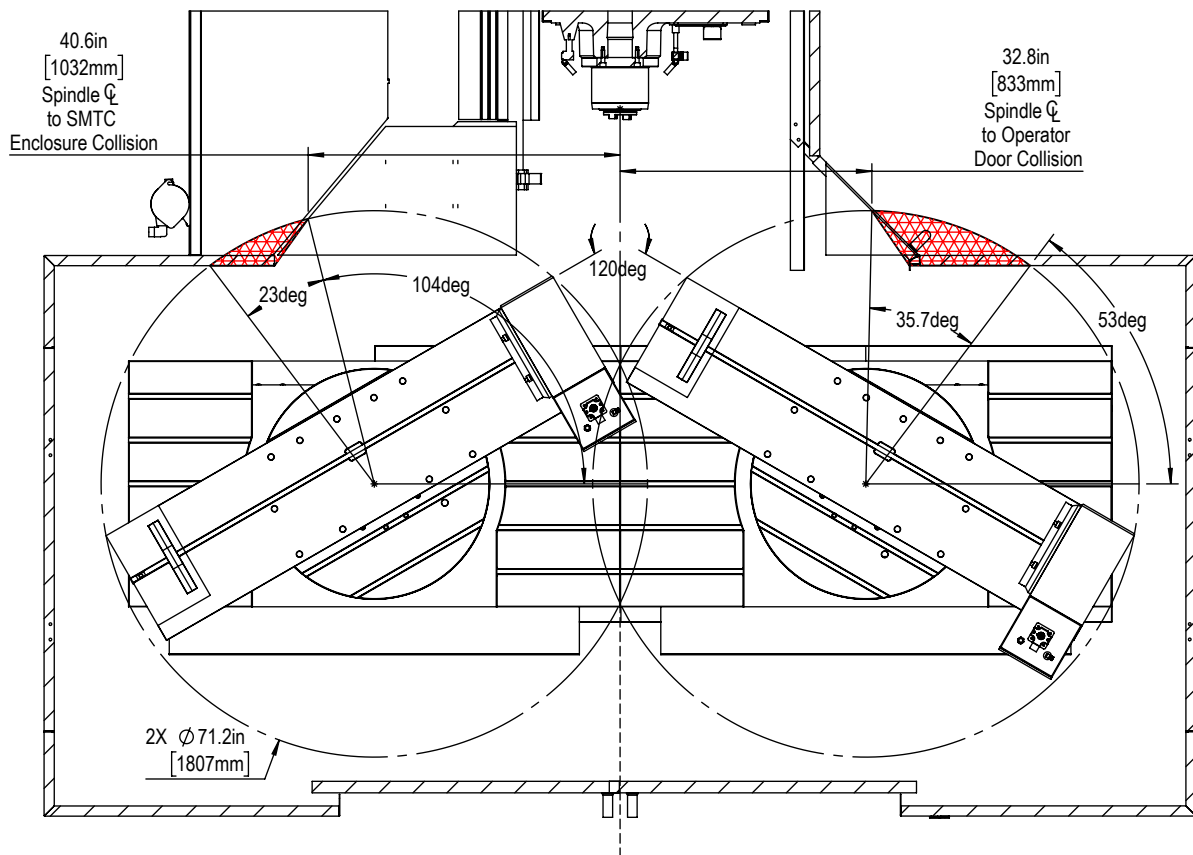

X&Z-Axis Travel

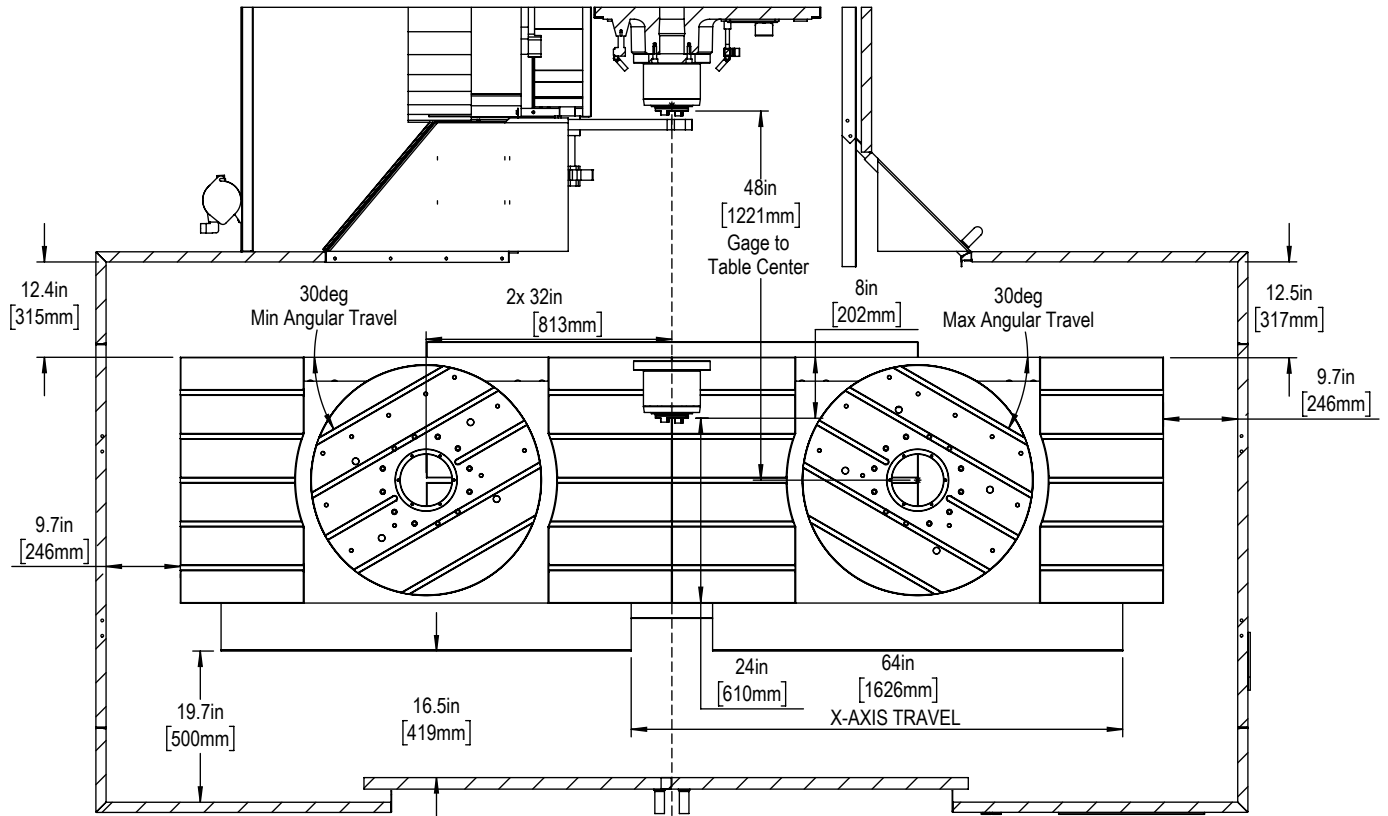

Y-Axis Travel

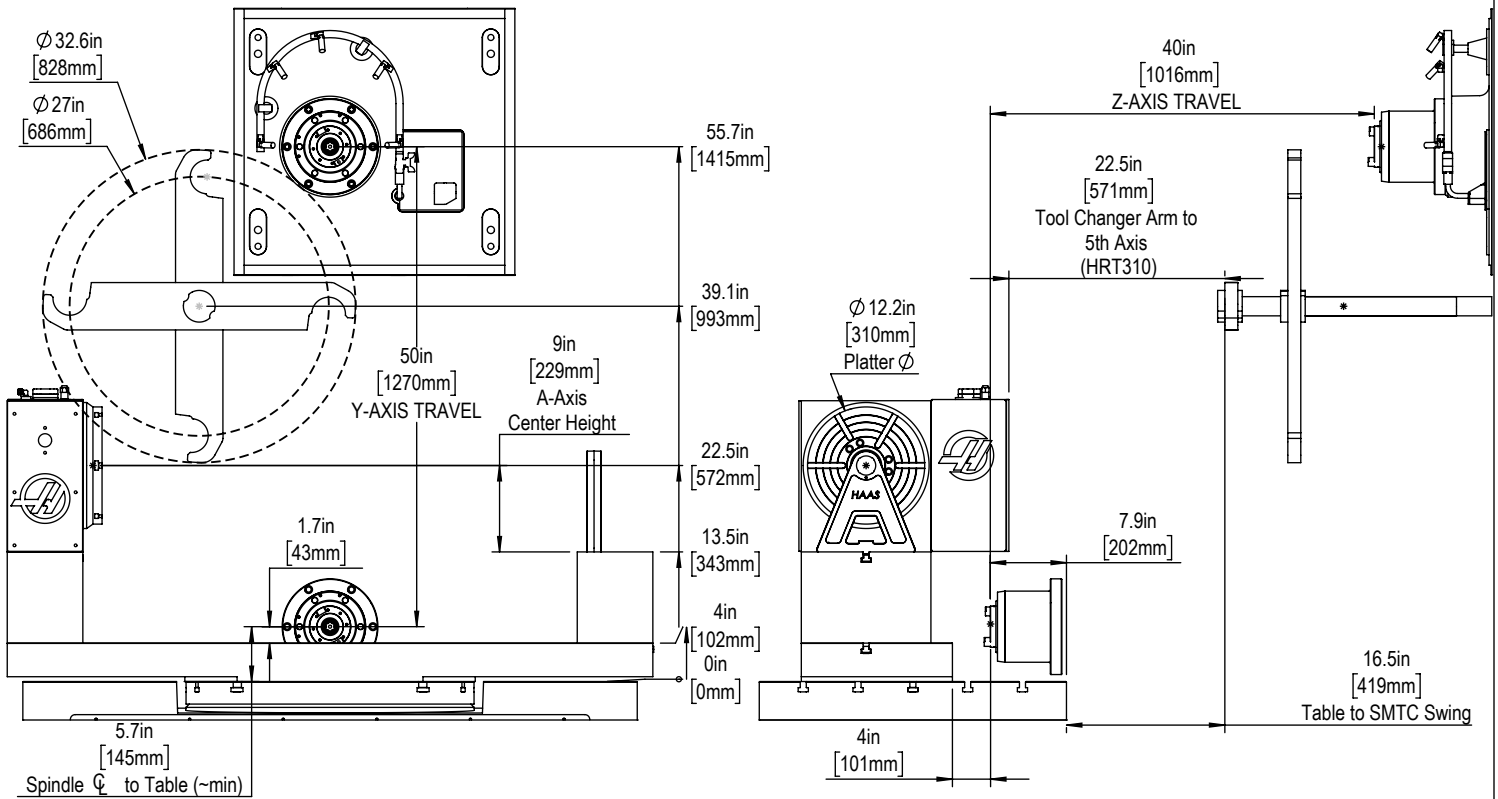

X&Z-Axis Travel

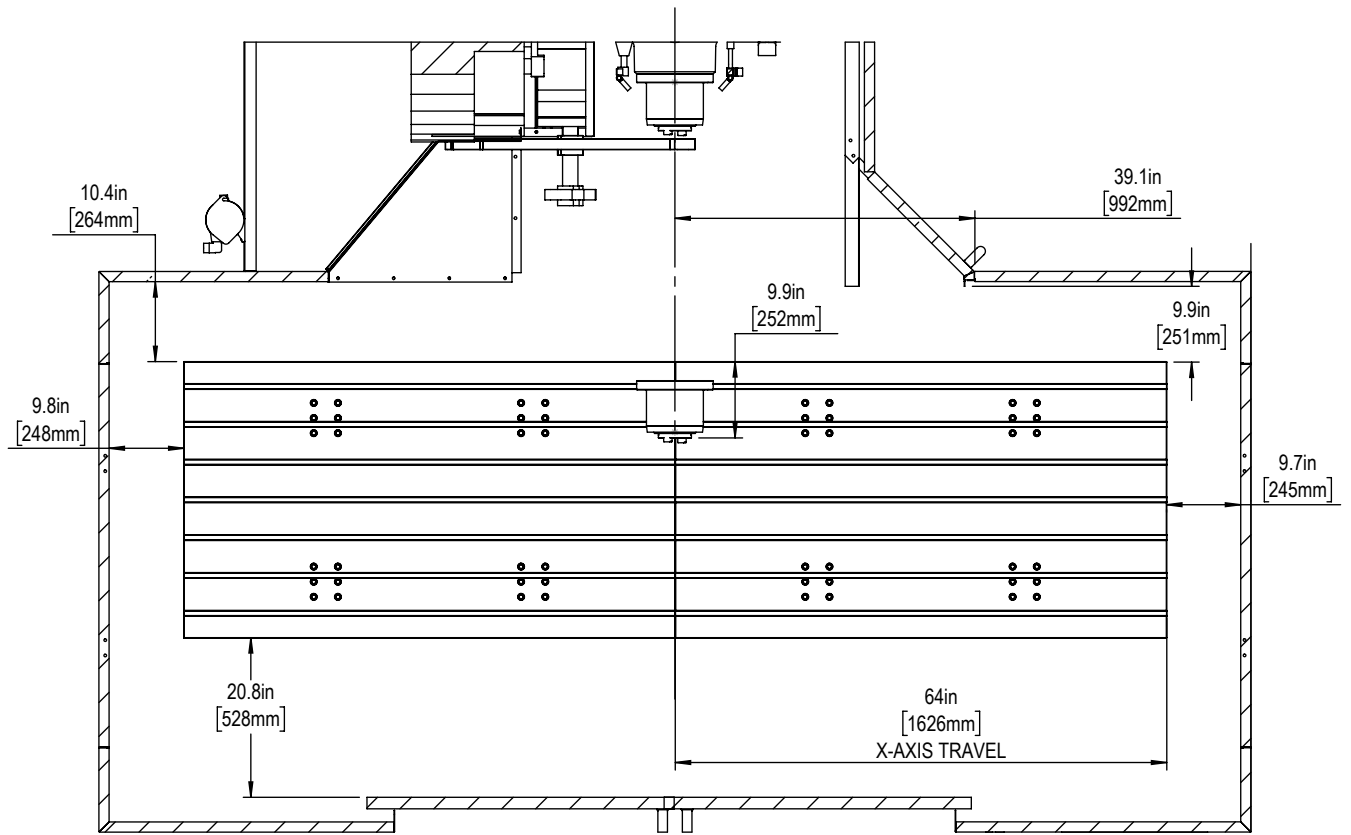

Y-Axis Travel

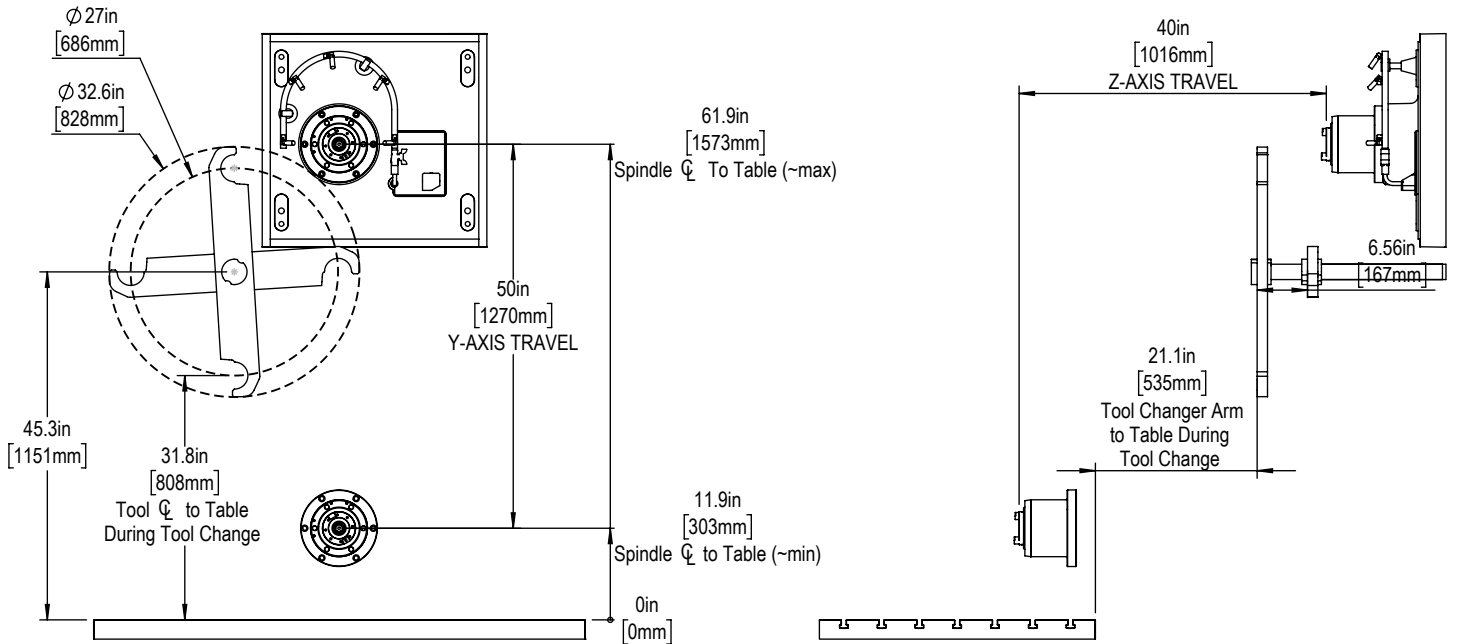



Table

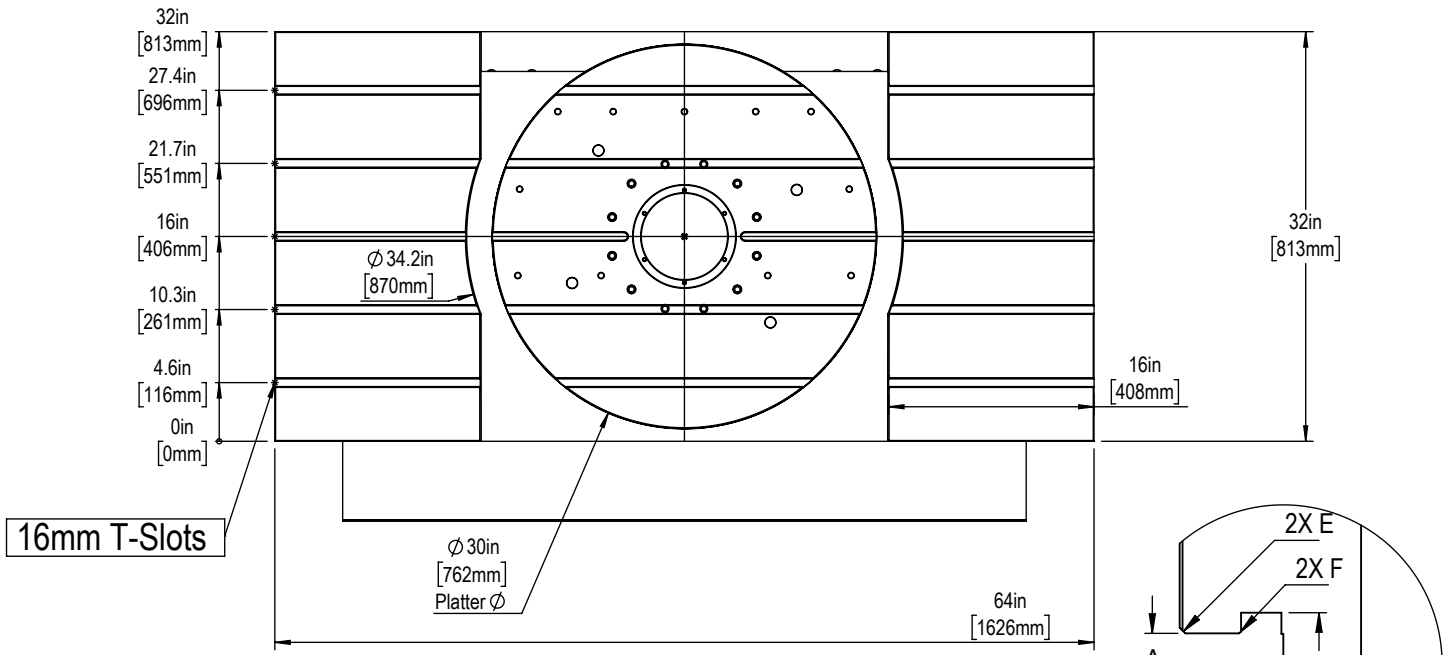

16mm T-Slots

ϕ 30in  
[762mm]  
Platter ϕ

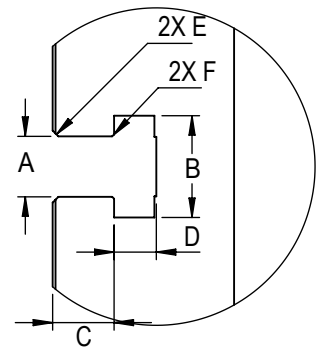

T-Slot Dimensions in inches

Slot Size	A	B	C	D	E	F
12mm	0.438 <sup>+0.002</sup> / <sub>-0.000</sub>	0.76 ± 0.02	0.310 ± 0.010	0.318 ± 0.010	0.03x45°	0.020x45°
16mm	0.628 ± 0.002	1.06 ± 0.02	0.640 ± 0.010	0.420 ± 0.010	0.06x45°	0.020x45°

Standard no 4th Axis Table

4th Axis Platter

11X 1/2-13 UNC-2B ∇ 1.000

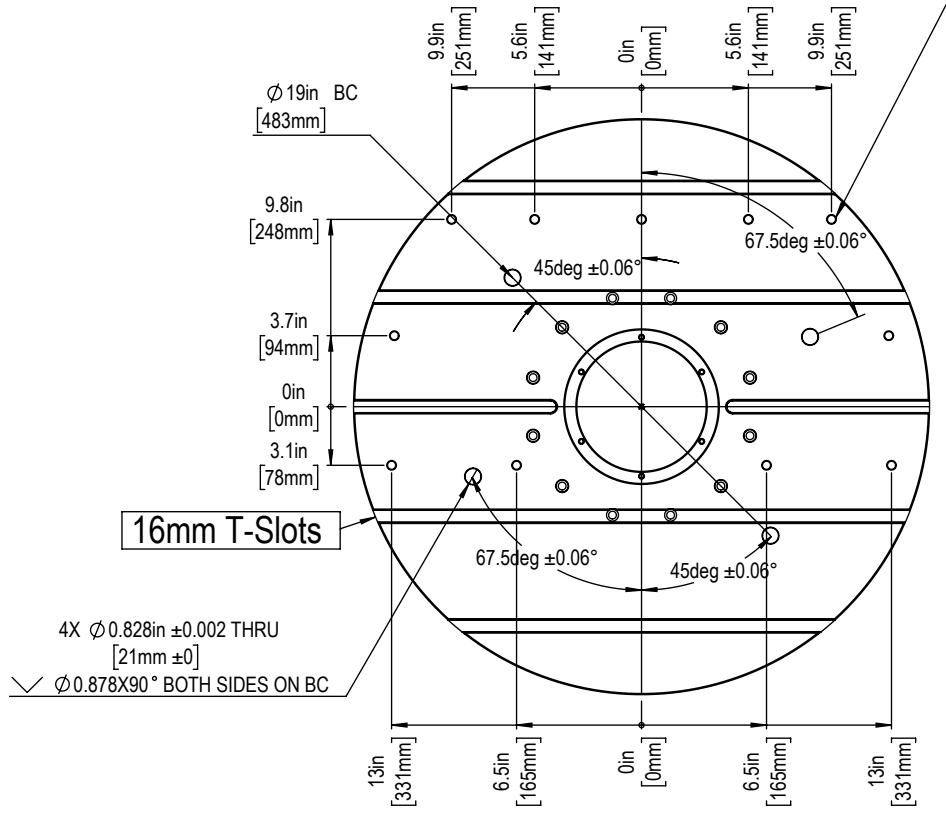
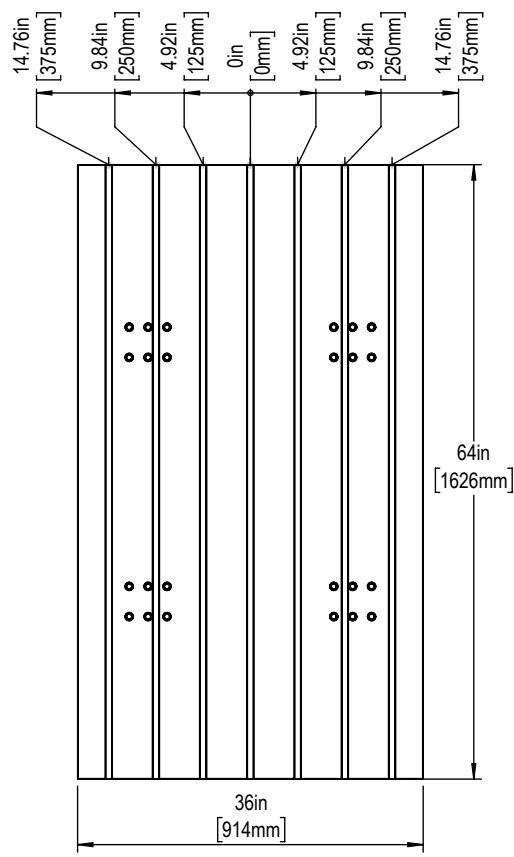

All dimensions based on stackup of sheetmetal, subject to variation of 1/2" ( 13mm) Due to continual product improvements, dimensions are subject to change without notice