

LGS Series

Switching automation light grid

Manual



IO-Link



Your automation, our passion.

 **PEPPERL+FUCHS**

With regard to the supply of products, the current issue of the following document is applicable: The General Terms of Delivery for Products and Services of the Electrical Industry, published by the Central Association of the Electrical Industry (Zentralverband Elektrotechnik und Elektroindustrie (ZVEI) e.V.) in its most recent version as well as the supplementary clause: "Expanded reservation of proprietorship"

Worldwide

Pepperl+Fuchs Group
Lilienthalstr. 200
68307 Mannheim
Germany
Phone: +49 621 776 - 0
E-mail: info@de.pepperl-fuchs.com

North American Headquarters

Pepperl+Fuchs Inc.
1600 Enterprise Parkway
Twinsburg, Ohio 44087
USA
Phone: +1 330 425-3555
E-mail: sales@us.pepperl-fuchs.com

Asia Headquarters

Pepperl+Fuchs Pte. Ltd.
P+F Building
18 Ayer Rajah Crescent
Singapore 139942
Phone: +65 6779-9091
E-mail: sales@sg.pepperl-fuchs.com
<https://www.pepperl-fuchs.com>

1	Introduction	5
2	Declaration of conformity.....	6
2.1	Declaration of Conformity	6
3	Safety	7
3.1	Symbols relevant to safety	7
3.2	Intended Use	7
4	Product Description.....	9
4.1	Use and Application	9
4.2	Indicators and Operating Elements.....	9
4.3	Interfaces and connections.....	11
4.4	Accessories	12
4.5	Scope of Delivery	12
5	Installation	13
5.1	Preparation.....	13
5.2	Mounting	13
5.3	Multiple Positions	16
5.4	Connecting the Sensor Rails.....	16
5.5	Storage and Transportation.....	19
6	Commissioning	20
6.1	Final Assembly	20
6.2	Commissioning the Light Grid	20
7	Operation	21
7.1	Operating the Light Grid	21
7.1.1	Object detection (overhang control).....	26
7.1.2	Monitoring the object height with height controls	27
7.1.3	Object identification	28
7.2	Commissioning and Operating the Light Grid with IO-Link	29

- 8 Maintenance and Repair30**
 - 8.1 Maintenance..... 30**
 - 8.2 Repair 30**

- 9 Troubleshooting31**
 - 9.1 Troubleshooting..... 31**

- 10 Appendix.....33**
 - 10.1 Technical Data..... 33**
 - 10.2 Type Code..... 36**
 - 10.3 Response Times and Number of Beams 36**
 - 10.4 Profile length and weight..... 40**
 - 10.5 Accessories 41**
 - 10.5.1 Installation accessories 41**
 - 10.5.1.1 Mounting Aid OMH-SLCT-01 42
 - 10.5.1.2 Mounting Aid OMH-LGS-01 42
 - 10.5.1.3 Alignment aid 43
 - 10.5.2 Connecting Cables 44**
 - 10.5.3 Accessories for IO-Link Operation 44**
 - 10.6 Parameterizing the light grid 45**

1 Introduction

Congratulations

You have chosen a device manufactured by Pepperl+Fuchs. Pepperl+Fuchs develops, produces and distributes electronic sensors and interface modules for the market of automation technology on a worldwide scale.

Before you install this device and put it into operation, please read the operating instructions thoroughly. The instructions and notes contained in this operating manual will guide you step-by-step through the installation and commissioning procedures to ensure trouble-free use of this product. By doing so, you:

- guarantee safe operation of the device
- can utilize the entire range of device functions
- avoid faulty operation and associated errors
- reduce costs from downtimes and incidental repairs
- increase the effectiveness and operating efficiency of your plant.

Store this operating manual somewhere safe in order to have it available for future work on the device.

Directly after opening the packaging, please ensure that the device is intact and that the package is complete.

Contact

If you have any questions about the device, its functions, or accessories, please contact us at:

Pepperl+Fuchs Group
Lilienthalstraße 200
68307 Mannheim, Germany
Telephone: +49 (0)621 776-1111
Fax: +49 (0)621 776-271111
Email: fa-info@de.pepperl-fuchs.com

Symbols used

The following symbols are used in this manual:



Note

This symbol draws your attention to important information.



Handling instructions

You will find handling instructions beside this symbol

2 Declaration of conformity

2.1 Declaration of Conformity

This product was developed and manufactured in line with the applicable European standards and directives.



Note

A declaration of conformity can be requested from the manufacturer.

The product manufacturer, Pepperl+Fuchs Group, 68307 Mannheim, Germany, has a certified quality assurance system that conforms to ISO 9001.



3 Safety

3.1 Symbols relevant to safety



Danger!

This symbol indicates an imminent danger.
Non-observance will result in personal injury or death.



Warning!

This symbol indicates a possible fault or danger.
Non-observance may cause personal injury or serious property damage.



Caution!

This symbol indicates a possible fault.
Non-observance could interrupt the device and any connected systems and plants, or result in their complete failure.

3.2 Intended Use

The LGS automation light grid is a compact optical light grid that consists of a emitter strip and a receiver strip. The detection field to be monitored is located between the emitter strip and the receiver strip. The electronics for level measurement are located in the receiver strip.

Areas of Use

- Object detection in the packaging and material handling sectors
- Detecting and counting irregular objects
- Measuring and sorting objects of different heights (height control)
- Presence and overhang control in material handling systems
- Overhang control of load heights in transport systems and material handling applications
- Web sag monitoring
- Position or shape monitoring
- Gap detection



Caution!

Not a safety component

The light grid is not a certified safety light grid in accordance with EN 61496. It is also not a safety component under the terms of the EU Machinery Directive 2006/42/EC. The light grid must therefore not be used for the purpose of preventing risk to individuals or parts of the body.

Always operate the device as described in these instructions to ensure that the device and connected systems function correctly. The protection of operating personnel and plant is guaranteed only if the device is operated in accordance with its intended use.

The device and its input and output circuits must be operated from a power supply that fulfills the requirements of PELV/SELV systems.

Only use recommended original accessories.

The operating company bears responsibility for observing locally applicable safety regulations.

Installation and commissioning of all devices may be performed only by trained and qualified personnel.

It is dangerous for the user to make changes and/or repairs. Additionally, doing so voids the warranty and excludes the manufacturer from any liability. In the event of any serious errors, stop using the device. Secure the device against unintended operation. To have the device repaired, return it to your local Pepperl+Fuchs representative or your sales center.

4 Product Description

4.1 Use and Application

LGS series: Touch it, save it—intelligent automation light grid with extras

Features

- Adjustable beam crossover for refining the resolution. The beam crossover does not alter the response time
- Optical synchronization of both outer beams possible
- Three separate outputs for height control
- Light-on or dark-on options
- Parameterizable object detection
- Parameterizable beam suppression (blanking)
- Operation via touch field or external input
- IO-Link interface for service and process data, and for parameterization

Description

In addition to the usual standard functions, LGS series light grids feature a range of useful extra functions previously found only in much more expensive device classes. These functions include ultra-quick object detection even with beam crossover, the option of identifying objects, and remote communication via an IO-Link interface. The blanking function can be used to deactivate two connected beam areas if unfavorable installation conditions result in plant components extending into and interrupting the detection field. The standby operating mode is another feature for applications where light grids are not in continuous operation.

The LGS is modular in design and available with five different beam gaps (8 mm, 17 mm, 25 mm, 50 mm, and 100 mm) and detection field heights ranging from 100 mm to 3200 mm to enable extensive monitoring of the evaluation area. Integrated signal evaluation means it is not necessary to mount a separate additional switching device. The slimline profiles can easily be mounted using existing holes, the rear continuous groove, or the fixtures available as accessories, enabling light grids in the LGS series to be used to maximum effect and tailored to the specific application.

The switching light grid has one switching output, which displays an identified object, and three height control outputs.

The LGS receiver strip also has an IO-Link interface, enabling advanced parameterization, extensive configuration, identification, and diagnosis of the light grid. This requires operation on an IO-Link master.

The SC (stability control) diagnostic output indicates an insufficient functional reserve, e.g., due to misalignment or soiling. The receiver strip can be taught in for various objects via a teach-in input. The touch button can also be replicated externally via this input.

4.2 Indicators and Operating Elements

Emitter strip

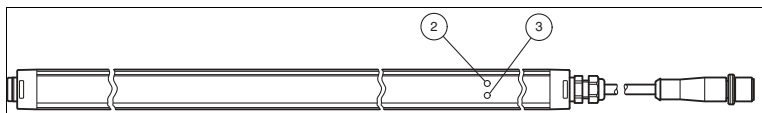

Figure 4.1 Function indicator on the emitter strip

- 2 Operating indicator: Indicates power on or power save mode
- 3 Status indicator: Indicates transmission power, fault state, or active test input

Receiver strip

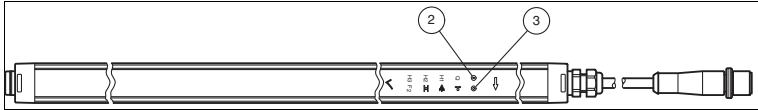

Figure 4.2 Function indicator on the receiver strip

- 2 Operating indicator: Indicates power on, power save mode, active IO-Link, or fault state
- 3 Status indicator: Indicates detection field status, functional reserve, or fault state

On the receiver strip behind the plastic front panel there are 12 illuminated pictograms. The pictograms indicate the functional state and allow you to parameterize the system. The two outer pictograms indicate the position of the two operating buttons (capacitive touch buttons) for parameterization.

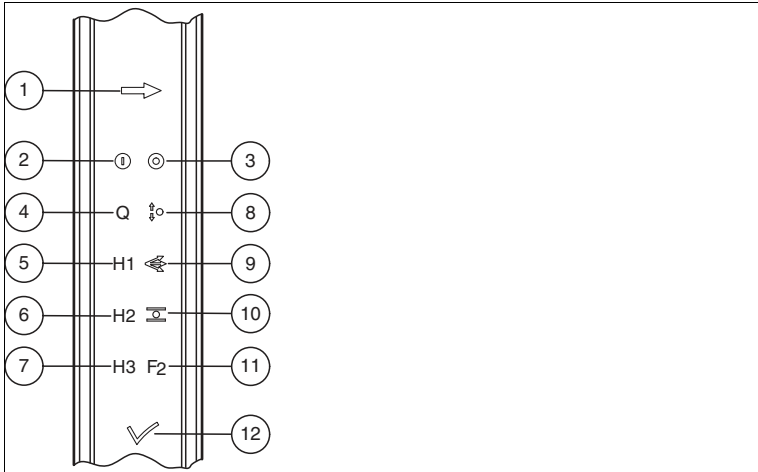

Figure 4.3 Touch field: Function indicators on the receiver strip

Touch buttons

1	Menu button	Function selection
12	OK button	Function confirmation

Function status indicators, level 1

4	Detection field status and object teach-in switching output	Teach in object or display object detection
5	Height output 1	Teach in height 1 or display taught-in height 1
6	Height output 2	Teach in height 2 or display taught-in height 2
7	Height output 3	Teach in height 3 or display taught-in height 3
8	Object position	Object detection for moving objects Object detection for static objects
9	Crossover	Beam crossover active Beam crossover deactivated
10	Object tolerance	Tolerance beam for objects active Tolerance for objects deactivated
11	F2	Activate second level

Function status indicators, level 2

4	Q (F2)	Beam suppression (blinking) for interfering objects
5	H1 (F2)	Inverse operation (gap detection)
6	H2 (F2)	Light-on or dark-on switching type
7	H3 (F2)	Reset factory setting
8	Object position (F2)	Signal tracking active Signal tracking inactive

4.3 Interfaces and connections

The electrical connections are established using two M12 connectors. The transmitter strip has a cable with a 4-pin connector and the receiver strip a cable with an 8-pin connector.

Transmitter strip

Figure 4.4 Emitter unit connection layout

- 1 24 V DC
- 2 Range (In)

- 3 0 V DC
- 4 Test (In)

Receiver strip

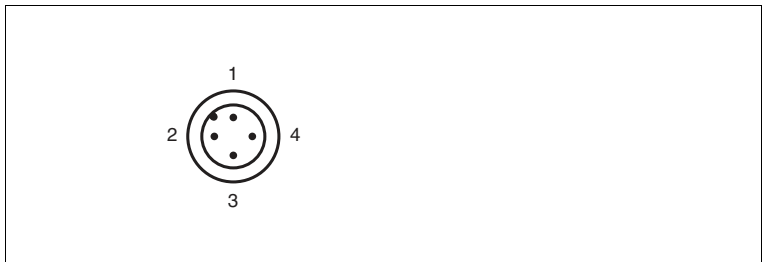
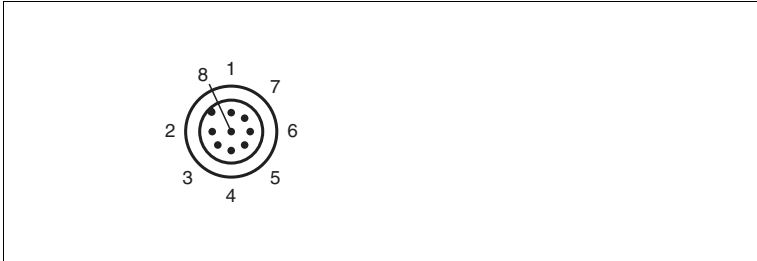

Figure 4.5 Receiver strip connection layout

- 1 + UB
- 2 SC (Stability Control, Out)
- 3 0 V DC
- 4 C/Q (IO-Link / Out)
- 5 H1 (Out)
- 6 H2 (Out)
- 7 H3 (Out)
- 8 Teach-in (In)

IO-Link communication is established via the C/Q connector (pin 4).

4.4 Accessories

An extensive range of accessories with detailed descriptions can be found in the appendix see chapter 10.5.

4.5 Scope of Delivery

The scope of delivery includes:

- Emitter strip and receiver strip
- Manual
- Cable lug and spare housing screw

Fixtures and cables are not included in the scope of delivery. See the appendix or visit <http://www.pepperl-fuchs.com> for a selection of compatible mounting aids and recommended cables.

5 Installation

5.1 Preparation



Unpacking the Device

1. Check the packaging and contents for damage.
 - ↳ In the event of damage, inform the shipping company and notify the supplier.
2. Check the package contents against your order and the shipping documents to ensure that all items are present and correct.
 - ↳ Should you have any questions, direct them to Pepperl+Fuchs.
3. Retain the original packaging in case the device is to be stored or shipped again at a later date.



Note

Preventing Extraneous Light and Reflections

Situations in which the receiver is exposed to powerful extraneous light (e.g., from flashing lamps or direct sunlight) must be avoided. The influence of other optical sensors should also be prevented through suitable positioning or the use of partitions. There must be no reflective surfaces in the detection field, since reflections may prevent the detection of objects.

5.2 Mounting

Remember to keep the detection field free of obstacles wherever possible. The first or last beam in particular is used for visual synchronization between the emitter strip and the receiver strip. If both synchronous beams are interrupted, the detection field is no longer measured.

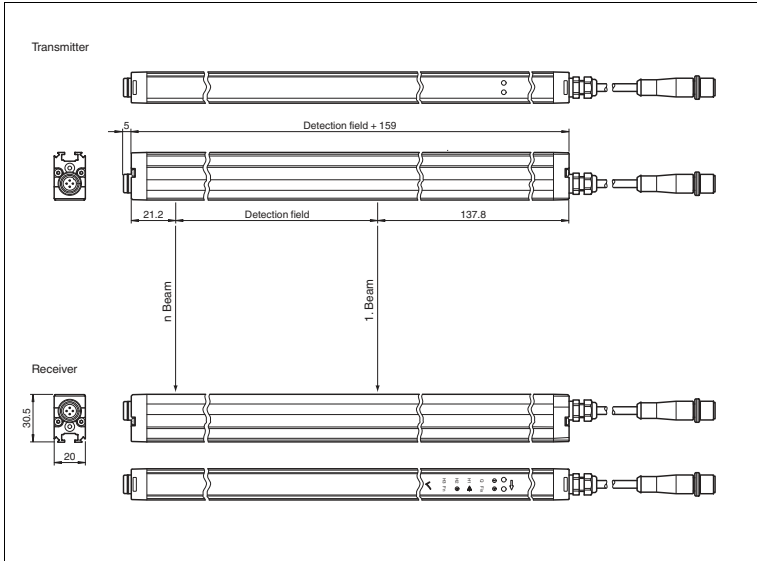

Figure 5.1 Light Grid Dimension Drawing

To mount the slim panels, use customized bore holes ($d = 4.5 \text{ mm}$ for M4 screws) or a rear, continuous groove (for flat M6 nuts in accordance with ISO 4035).

Various fixtures are available for mounting the light grid see chapter 10.5.1.

Mounting Using the Rear Groove

There is a continuous groove located on the rear of the strip on the light grid. Standard flat M6 nuts in accordance with DIN 4035 fit into this groove. Once these nuts have been inserted, they can be used to mount the light grid.

Mounting Using Holes Drilled by the Customer

The light grids can be mounted using user-defined holes. The maximum screw size is M4. Make sure you follow the instructions when positioning the hole. Improper handling can damage the internal electronics.



Drilling Holes

1. Mark the position of the holes. Focus on the continuous line on the side of the light grid .
 2. Mark the position of the holes.
 3. Using a 4.5 mm diameter drill, drill all the way through the housing.
 4. Deburr the hole.
 5. Repeat the first steps until all holes have been drilled.
 6. Make sure that the aluminum chips do not scratch the optical surface.
- ↳ Secure the light grid in its final position using the drilled holes.

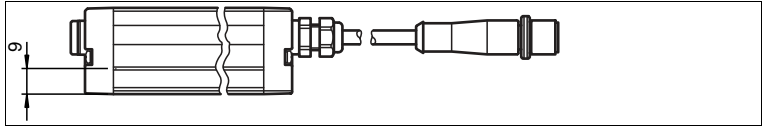

Figure 5.2 Position of the central point for the mounting holes

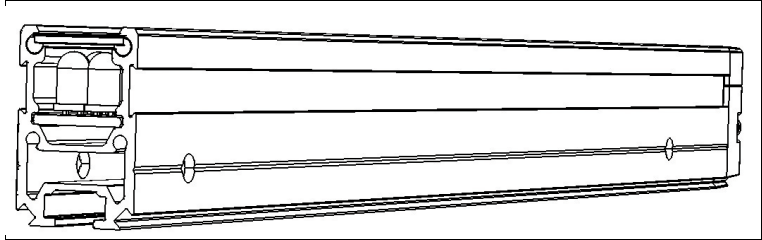

Figure 5.3 Mounting holes



Mounting

1. Align the emitter strip and receiver strip so they are parallel with one another and at the same height.
2. The strips must be aligned with one another with an accuracy of approximately $\pm 5^\circ$.
3. During mounting, ensure that the two strips have the same orientation. (Cable outlet facing either upward or downward on both strips.)
4. The maximum detection range must not be exceeded.

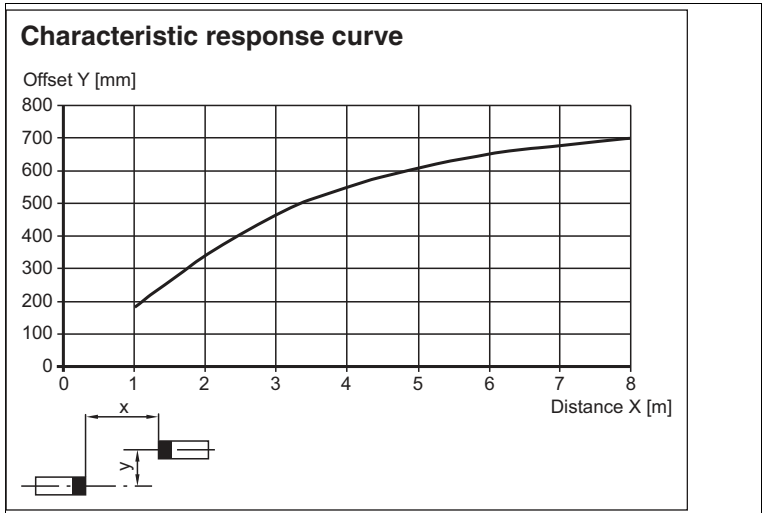

Figure 5.4 Maximum offset between emitter and receiver

5.3 Multiple Positions



Note

If several light grids are operating close to each other, care must be taken to prevent cross-talk. This can be achieved by swapping the emitter and receiver, or by ensuring a sufficient distance between the two light grids.

The illustration below indicates how to mount two light grids with a swapped emitter and receiver.

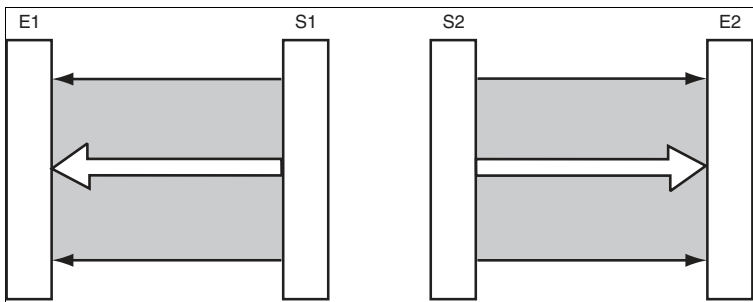

Figure 5.5 Multiple assignment of two pairs of light grids

5.4 Connecting the Sensor Rails



Caution!

Electrical connection

Wiring work that requires the opening and closing of electrical connections must always be performed with the power disconnected.

Use a Class 2 power supply to supply the power (certified according to UL 1310).

Connecting the Emitter Strip

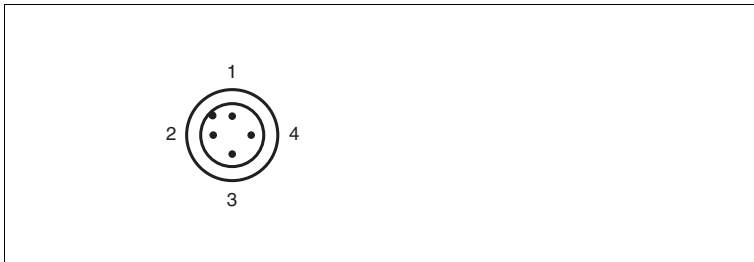

Figure 5.6 Emitter unit connection layout

- 1 24 V DC
- 2 Range (In)

- 3 0 V DC
- 4 Test (In)

Connect the emitter strip after the top pinout. Insulate the unused wires. See the switching example shown on the following page → see Figure 5.8 on page 19.

Range input

The transmitter strip has a range input (pin 2) that adapts the transmitting power to the relevant sensing range in the application. The transmitter attains a maximum sensing range of 1.6 m (or 2 m with option /35) if the input is open. **If the application requires a longer sensing range (6 m or 8 m with /35), the input must be connected either to + UB or 0 V.** The reduction in the transmitting power also prevents extraneous light from interfering with other sensors located in the direct vicinity.

Test input

The transmitter strip has a test input (pin 4) that can be used to test the function of all switching outputs on the system by activating the test input or operate the system in energy-saving mode. The input can be connected either to + UB or 0 V.

- **Function test:** When the strip is activated for less than 1.2 s, the transmitter beams switch off and the outputs on the receiver strip switch on in the same way as when a beam is interrupted. The outputs for the height control can also be tested in this way, if the relevant height control parameters are available.
- **Energy-saving mode:** If the test input is activated for longer than 1.2 s, the system switches to energy-saving mode with minimal energy consumption and no functions. The light grid reverts back to normal mode immediately when the test input is deactivated.

Connecting the Receiver Strip

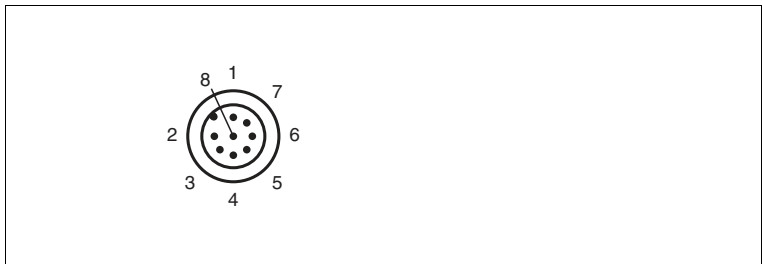

Figure 5.7 Receiver strip connection layout

- 1 + UB
- 2 SC (Stability Control, Out)
- 3 0 V DC
- 4 C/Q (IO-Link / Out)
- 5 H1 (Out)
- 6 H2 (Out)

- 7 H3 (Out)
- 8 Teach-in (In)

Connect the receiver strip after the top pinout. All outputs are short-circuit proof. Insulate the unused wires. See the switching example shown on the following page → see Figure 5.8 on page 19.

Stability Control Output (SC)

The SC switching output indicates an insufficient functional reserve and makes status indicator 3 flash at 4 Hz with a delay of 5 seconds. The SC switching output only switches off once there is sufficient functional reserve again, for example, if the front lenses are cleaned or the strips are readjusted.

Switching Output (C/Q)

This signal output is active (switched on for dark on, opposite for light on) if an object is within the detection range, or if a taught-in object is detected. This is shown by status indicator 3 and 4 respectively.

Height Control Outputs (H1, H2, H3)

These three independent signal outputs are active if objects in the detection field match the position of the taught-in height controls see chapter 7.1.2. The outputs then report the same statuses as the function status indicators 5 (H1), 6 (H2), and 7 (H3). If no height controls are parameterized, the signal outputs are always inactive.

Connecting External Operating Buttons (Teach-In Input)

The receiver strip is equipped with a teach-in input. This input can be used to route out the two operating buttons and to connect them externally. The function of the menu button is connected via an external normally-open contact to + UB. The OK button is connected via an external normally-open contact to 0 V. To prevent a short circuit when both normally-open contacts are actuated simultaneously, a 1 k Ω /2 W resistor must be installed between the NO contact and 0 V.

Parameterization can be locked to prevent the **menu button** being pressed unintentionally (keyboard lock). To do this, set the external teach-in input permanently to + UB.

Switching Example

The LEDs on the outputs are optional.

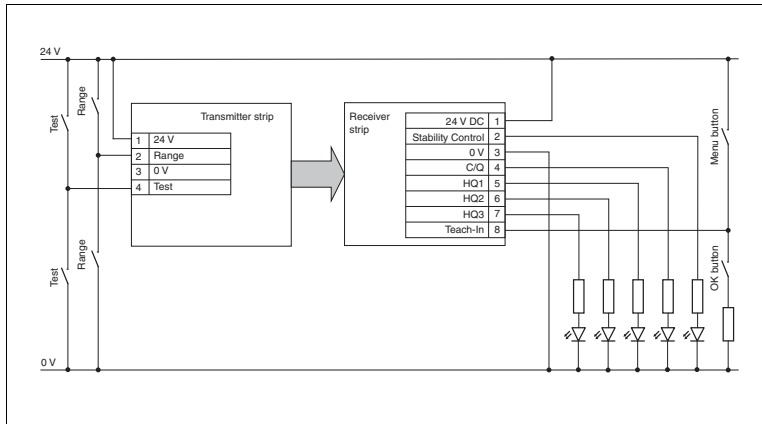

Figure 5.8 Connection example LGS



Grounding/Shielding

The system does not require grounding in standard cases. If EMC faults occur, use a grounding cable with the cable lug supplied in the scope of delivery. The grounding/shielding must always be mounted on the receiver strip. This is purely functional grounding rather than protective grounding. It acts solely as a down conductor for cable-related faults and is not subject to any safety guidelines (e.g., personnel protection).

Ground/shield the device as follows:

1. Make up a grounding cable (max. 1 mm²) using the supplied cable lug.
2. Remove one housing screw from the cover at the cable end, using a Torx T8 screwdriver.
3. Place the cable lug with the prepared cable under the cover and tighten the housing screw again.
4. Connect the other end of the ground cable to adjacent metal components (e.g., mounting base, frame, etc.).

↳ The sensor is now grounded.

5.5 Storage and Transportation

Keep the original packaging. Always store and transport the device in the original packaging.

Store the device in a clean and dry environment. The permitted ambient conditions must be considered, see datasheet.

6 Commissioning

6.1 Final Assembly

Checking the Mounting and Settings

1. Check the position of the light strips in relation to one another. The emitter strip and receiver strip must be aligned with one another with an accuracy of approximately $\pm 5^\circ$.
2. The light strips can be operated briefly to check that the final assembly has been performed correctly. The light strips are aligned perfectly with each other when the yellow status LED on the receiver strip does **not** light up continuously or flash.
3. Now secure the light strips. Check all screw connections and tighten as necessary.
4. Check the cabling, referring to the wiring diagrams.

Remember to keep the detection field free of obstacles wherever possible. The first or last beam in particular is used for visual synchronization between the emitter strip and the receiver strip. If both synchronous beams are interrupted, the detection field is no longer measured.

The signal needs to be calibrated to achieve the best possible resolution for the relevant application. Therefore, after any modifications to the application (installation situation), start the system to recalibrate the signal and maintain the same level of availability.

The signal output responds to detected objects, heavy soiling on the lenses, or misaligned profiles. The electronics compensate for signal changes caused by gradual soiling or temperature changes. If a minimum of one light beam is interrupted, the output remains active until the light beam is interrupted (with dark on) or soiling is detected.

6.2 Commissioning the Light Grid



Commissioning

1. Check that the light grid is in the correct position.
2. Switch on the supply voltage. The operating status indicators on the emitter strip and receiver strip light up green.
3. If the status LED is not lit, the light grid is aligned. The status LED lights up when the device is misaligned or an object is detected.

↳ The two strips are perfectly aligned with one another and can now be configured see chapter 7.1.

To commission and operate the light grid via the IO-Link interface, please refer to the following section see chapter 7.2.

7 Operation

7.1 Operating the Light Grid

No objects or height controls are parameterized on delivery.

The grid is operated using the touch field on the front of the receiver strip. The system can be parameterized as required using the two operating elements and the icons on the receiver strip. Parameterize the light grid by pressing the menu button. The "Q" icon flashes in parameterization mode.

- Rapid flashing means: The function is not yet activated/taught in (the LED turns on briefly and then turns off for a long period)
- Slow flashing means: The function is activated/taught in (the LED turns on for a long period and then turns off briefly)

Pressing the menu button again activates all parameterizable functions in succession, and each relevant icon flashes brightly.

To teach in or activate the current parameter, press the OK button .





For information on operating via an external connection, see chapter 5.4.

If no operating buttons are pressed within a timeout period of 30 seconds, parameterization automatically ends. Any previously modified parameters are retained.



Factory Settings

To restore the factory settings, proceed as follows:

1. Press the Menu button  to enter parameterization mode.
2. Press the Menu button  repeatedly until the "F2" icon starts flashing.
3. Press the Menu button . This will take you to the 2nd parameterization level.
4. Press the Menu button  repeatedly until the "H3" icon starts flashing.

↳ If you now press the OK button , the light grid will be restored to its factory settings..

Factory Setting

Parameter	Status
Height control 1 – 3	Inactive
Beam crossover (3-way)	Active
Object position	Floating
Object tolerance	Active
Light-on/dark-on switching	Dark on
Beam suppression (blinking)	Inactive

Parameter	Status
Inverse operation (gap detection)	Inactive (solid objects)
Signal tracking	Inactive

Table 7.1 Factory settings of the light grid

Parameterization Status Indicator

To display the current statuses parameterized on the 1st level, briefly press the

OK button  outside of the parameterization menu.

This displays all the active functions for five seconds.

- Icon dimly lit: Function has not been parameterized or is disabled
- Icon bright and constantly lit: Function has been parameterized or is activated

The status of functions on the 2nd level can only be read while the relevant function is being parameterized:

LED flashing quickly = function disabled



LED flashing slowly = function enabled

Touch Field Overview



Figure 7.1 Touch field on the sensor for parameterization

Touch Field: Configurable Parameters, 1st Level

Parameter	Touch field icon	Description
Q object	Q	<p>Explanation of function: Teach in object. The object currently located in the detection field is taught in. Output Q is activated when the object is detected during operation. The "Q" icon lights up brightly to indicate this status.</p> <p>Detection field vacant: If the detection field is vacant when the OK button is pressed, any object previously taught in will be deleted and the Q switching output will respond to any interruption in the beam.</p> <p>Display function: The "Q" icon signals each interruption in the detection field in parallel to status indicator 3.</p>
Height control 1	H1	<p>Explanation of function: Teach in object height. The uppermost beam interrupted by the object currently located in the detection field is taught in as the height control. The H1 output switches on whenever this beam is interrupted during operation. The "H1" icon lights up brightly to indicate this status.</p> <p>Synchronization interrupted: The H1 output switches on if synchronization is lost, even if there is no corresponding object located in the detection field.</p> <p>Detection field vacant: If the detection field is vacant when the OK button is pressed, any height control previously taught in will be deleted and the H1 switching output will no longer respond.</p>
Height control 2	H2	Function as described for height control 1. The H2 switching output is activated.
Height control 3	H3	Function as described for height control 1. The H3 switching output is activated.
Object position		<p>Explanation of function: Type of object position. The object position is "floating" in the factory setting.</p> <p>Change function: Pressing the OK button changes the object position of a taught-in object from "floating" to "fixed."</p> <p>Reset function: Pressing the OK button again sets the object position to "floating" again.</p>
Beam crossover		<p>Beam crossover is active in the factory setting.</p> <p>Change function: Pressing the OK button disables beam crossover.</p> <p>Reset function: Pressing the OK button again enables beam crossover again.</p>
Object tolerance		<p>Explanation of function: When object tolerance is activated, this permits a deviation in the relevant object sizes of a resolution unit and improves object detection when beams are interrupted due to vibrations. The tolerance applies to both beam suppression (blanking) areas. Object tolerance is active in the factory setting.</p> <p>Change function: Pressing the OK button disables active tolerance of a resolution unit for object detection.</p> <p>Reset function: Pressing the OK button again enables object tolerance again.</p>

Parameter	Touch field icon	Description
2nd parameterization level	F2	Enable function: Pressing the OK button enables the 2nd parameterization level. Disable function: Pressing the OK button again quits the parameterization process.

Table 7.2 Touch field: configurable parameters, 1st level

Touch Field: Configurable Parameters, 2nd Level

Parameter	Touch field icon	Description
Beam suppression (blanking)	F2 Q	Explanation of function: Any beams detected within the taught-in object area during operation do not trigger a switching element function. Teach in object: Press the OK button: The object currently located in the detection field is taught in as beam suppression. Two different areas can be taught in simultaneously. However, at least one of the two outer synchronous beams must remain free. If the detection field is vacant when the OK button is pressed, any previously taught in beam suppression area is deleted again.
Inverse operation (gap detection)	F2 H1	The parameter can be modified before or after teaching in an object. Object type detection is set to "solid" in the factory setting. Modify: Pressing the OK button modifies the object type of a taught-in object from "solid" to "inverse" for gap detection. Reset: Pressing the OK button again sets object type detection to "solid" again.
Light-on/dark-on switching	F2 H2	Explanation of function: Dark on: The switching output is activated when beams in the detection field are interrupted (or there is no synchronization with the emitter). Light on: The switching output is activated when the detection field is vacant. The switching type is set to "dark on" in the factory setting. Enable function: Pressing the OK button changes the switching type of all Q, H1, H2, H3 switching outputs from "dark on" to "light on." Disable function: Pressing the OK button again sets the switching type to "dark on" again.
Reset factory setting	F2 H3	Pressing the OK button resets all parameters to the factory setting. Pressing the menu button again instead quits the parameterization process.

Parameter	Touch field icon	Description
Signal tracking	F2 Object position	<p>Explanation of function: In non-stable ambient conditions, e.g., soiling and temperature changes, signal tracking ensures that the response threshold remains constant. Reflective objects that are occasionally present along the detection field can distort signal tracking and cause switching faults. In the worst-case scenario, permanent detection is signaled even though there is no object in the monitoring field. In this case, the function must be disabled.</p> <p>Signal tracking is inactive in the factory setting.</p> <p>Enable function: Pressing the OK button enables signal tracking.</p> <p>When signal tracking is enabled, the specified resolution is reached. The value of the switching threshold is set to $\geq 60\%$.</p> <p>Parameterization via IO-Link Parameterization via IO-Link allows the response threshold and signal tracking to be defined independently of each other.</p> <p>=> Without tracking: The response threshold can be selected in 10 % increments between 0 = minimum threshold, 1 = 10 %, and 9 = 90 %.</p> <ul style="list-style-type: none"> • 0 = minimum threshold, no tracking, maximum gain, default value • 1 = 10 % of value of response threshold, no tracking • 2 = 20 % of value of response threshold, no tracking • ... • 9 = 90 % of value of response threshold, no tracking <p>=> With tracking: The response threshold can be freely selected between 10 % ... 90 %. This allows customized configuration between fine resolution (high threshold) and high immunity to reflective objects (low threshold).</p> <ul style="list-style-type: none"> • 10 % ... 90 % = value for response threshold that can be freely selected, with tracking <p>Disable function: Pressing the OK button again disables signal tracking.</p> <p>When signal tracking is disabled, the lowest switching threshold is configured. The optical resolution is increased by ≤ 4 mm.</p>

Table 7.3

Touch field: configurable parameters, 2nd level

7.1.1 Object detection (overhang control)

The LGS switching light grid uses the factory settings and does not require any further parameterization. Switching output Q reacts to every single object in the detection field.

Possible application-specific settings:

- Deactivate beam crossover
- Beam suppression (blanking) of permanent installations in the detection field
- Set switching mode of outputs to light on

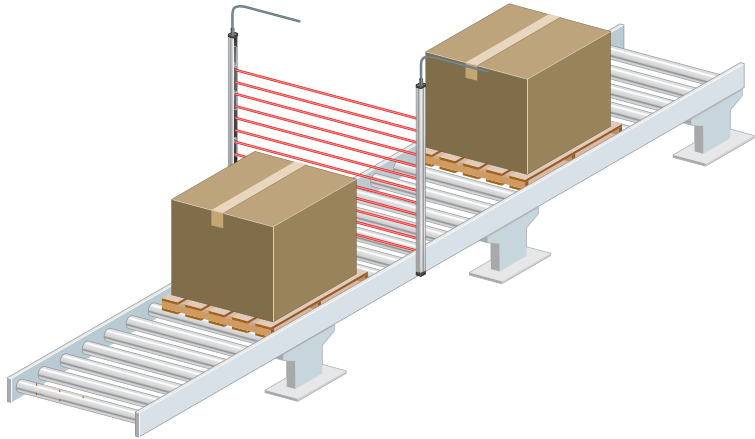

7.1.2 Monitoring the object height with height controls

The LGS switching light grid has been designed e.g. to monitor the load heights of pallets. An H switching output is therefore allocated for every load height. For example, the upper edge of the smallest object is taught in as height control 1 (H1), the upper edge of the middle object as height control 2 (H2) and the upper edge of the largest object as height control 3 (H3). No height output will switch on for any object smaller than height control 1. Only output H1 will switch on for objects larger than or equal to height control 1 but smaller than height control 2. Larger objects will trigger outputs H2 and H3 as well. The assignment of more than one beam to a height control is only possible via IO-Link. Switching output Q is activated every time an object is detected.

Possible application-specific settings:

- Deactivate beam crossover
- Beam suppression (blanking) of permanent installations in the detection field
- Set switching mode of outputs to light on

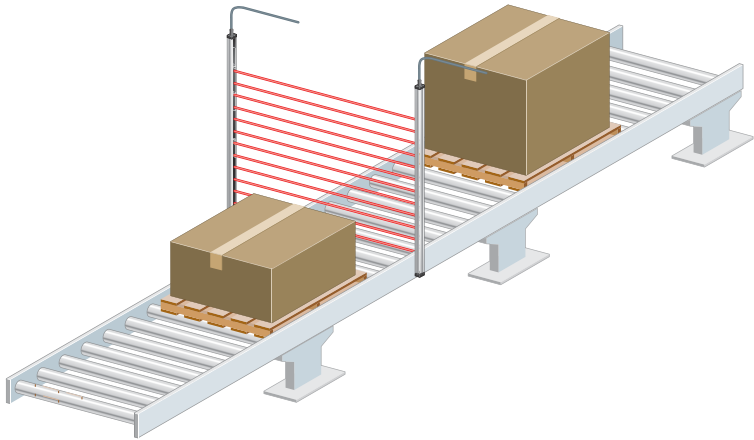

7.1.3 Object identification

The switching light grid can identify solid or perforated objects in the detection field from the interrupted light beams. Output Q is switched for the entire time that the object is in the detection field.

The object can also be set to a floating or fixed location in the detection field. If a fixed position is configured, output Q will only switch on if the identified object is exactly at this taught location. The inverse object identification operating mode is intended to detect holes, e.g., in plates. Either individual holes or contiguous hole patterns can be detected. The position of the outer edge of the plate in the detection field is irrelevant.

Possible application-specific settings:

- Deactivate beam crossover
- Beam suppression (blinking) of permanent installations in the detection field
- Set switching mode of outputs to light on

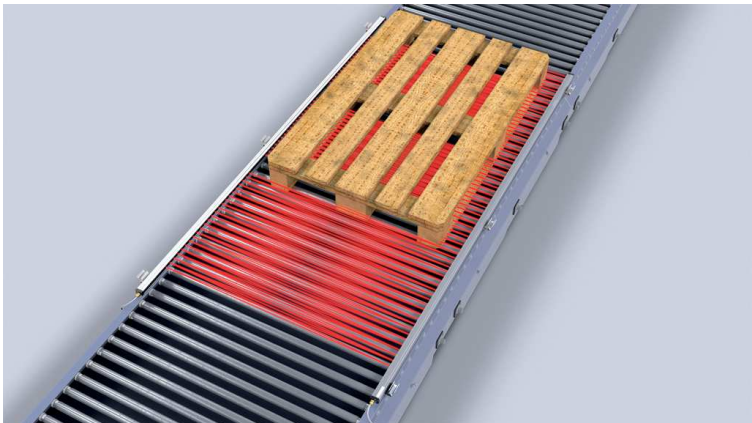



7.2 Commissioning and Operating the Light Grid with IO-Link



Commissioning with IO-Link

To activate the sensor via the IO-Link, proceed with the following steps:

1. Set the corresponding port on the IO-Link master to which the sensor is connected to IO-Link status.
2. When communication is successfully established, the green operating indicator flashes with short interruptions every second.

↳ The sensor now transmits process data and can be parametrized or diagnosis can be run.

Use preset parameters to configure, parameterize, and diagnose the sensors. To parameterize the sensors with an engineering tool, use the device description (IODD), which can be loaded into all system environments with IO-Link support. To operate the sensor in an FDT environment, you can also use a DTM.

See the device description and software, e.g., the IODD, DTM, and the FDT master application within the product at www.pepperl-fuchs.com/io-link.

8 Maintenance and Repair

8.1 Maintenance

To get the best possible performance out of your device, clean the optical unit on the device when necessary and always keep it clean.

When cleaning the optical unit you should note the following:

- Do not touch the optical unit with your fingers.
- Do not immerse the device in water. Do not spray the device with water or other liquids.
- Do not use a scouring agent to clean the surface of the device.
- Use a cotton or paper cloth moistened with water or isopropyl alcohol. The cloth must not be soaked!
- Remove any residual alcohol using a cotton or paper cloth moistened with distilled water. The cloth must not be soaked!
- Wipe the device surfaces dry using a lint-free cloth.

8.2 Repair

The device must not be repaired, changed, or manipulated. In case of failure, always replace the device with an original device.



Note

If it appears that safe operation of the sensor system is no longer possible, it must be taken out of operation and secured against inadvertent use.

Always send both parts of the device (transmitter and receiver strip) to Pepperl+Fuchs together for repair.

9 Troubleshooting

9.1 Troubleshooting

Before requesting field service, check that the following actions have been taken:

- The plant has been tested according to the following checklists.
- Telephone assistance obtained from the Service Center to isolate the problem.

Interference

- The sensor must be firmly mounted. It must not vibrate.
- The sensor must not be installed behind a cover.
- The sensor should be installed so it is protected from rain.

Eliminating Interference

Source of fault	Cause	Action
Emitter: Status indicator flashes quickly at 8 Hz	Fault state	1. Check the operating voltage. 2. Switch the voltage off and on again.
Receiver: Operating indicator (green) flashes in pulses at 0.8 Hz	Low voltage	Check the operating voltage.
Receiver: Operating indicator (green) flashes at 4 Hz	Short circuit at the outputs	Check the wiring at the outputs.
Receiver: Status indicator flashes at 4 Hz	Insufficient functional reserve	Clean the front panels; adjust the emitter and receiver.
Receiver: Status indicator flashes quickly at 8 Hz	Fault state during signal measurement	1. Check the operating voltage. 2. Switch the voltage off and on again.
Receiver: Switching output with detection signal although there is no object in the detection field	Reflective objects parallel to the detection field	Deactivate signal tracking (2nd level, object position).
Non-specific flashing of the indicators on the light grid		Switch the voltage off and on again.





- If none of the suggestions above corrects the problem, please contact the Service Center.

Load factory setting



Factory Settings

To restore the factory settings, proceed as follows:

1. Press the Menu button  to enter parameterization mode.
 2. Press the Menu button  repeatedly until the "F2" icon starts flashing.
 3. Press the Menu button . This will take you to the 2nd parameterization level.
 4. Press the Menu button  repeatedly until the "H3" icon starts flashing.
- ↳ If you now press the OK button , the light grid will be restored to its factory settings..

10 Appendix

10.1 Technical Data

General specifications

Effective detection range	Standard : 0.3 ... 6 m Option /35: 0.5 ... 8 m LGS100: When beam crossover is activated, the detection range starts at 0.6 m
Threshold detection range	Standard : 7.5 m Option /35: 10 m
Light source	IREC
Light type	modulated infrared light , 850 nm
Field height	See chapter 10.3
Beam crossover	Factory setting: three beam crossing, deactivateable
Beam blanking	adjustable max. 2 fixed suppressible beam areas (blanking)
Beam spacing	LGS8 = 8.33 mm; LGS17 = 16,67 mm; LGS25 = 25 mm; LGS50 = 50 mm; LGS100 = 100 mm
Number of beams	See chapter 10.3
Operating mode	Emitter: Emitter power adjustable in two ranges
Optical resolution	without beam crossover: see beam spacing with beam crossover: 4 / 8,5 / 12,5 / 25 / 50 mm. Only between 25 % ... 75 % of range
Angle of divergence	10 °
Ambient light limit	> 50000 Lux (if external light source is outside the opening angle)

Functional safety related parameters

	LGS8	LGS17	LGS25	LGS50	LGS100
MTTF _d	21 a	25 a	34 a	56 a	78 a
Mission Time (T _M)	20 a	20 a	20 a	20 a	20 a
Diagnostic Coverage (DC)	60 %	60 %	60 %	60 %	60 %

Indicators/operating means

Operation indicator	Power on: LED green, statically lit , Undervoltage indicator: Green LED, pulsing (approx. 0.8 Hz) , short-circuit : LED green flashing (approx. 4 Hz)
Function indicator	Emitter: Yellow LED, illuminates at high emitting power, off at low emitting power Receiver: Yellow LED: illuminates when an object is detected flashes when falling short of the stability control (4 Hz) Error message: Yellow LED flashes (8 Hz) in emitter and receiver
Control elements	Receiver: 2 touch buttons for programming

Electrical specifications

Operating voltage	18 ... 30 V DC
Ripple	10 %
No-load supply current	Emitter ≤ 50 mA Receiver: ≤ 150 mA (without outputs)

Interface

Interface type	IO-Link
Protocol	IO-Link V1.0
Mode	COM 2 (38.4 kBaud)

Input

Test input	Emitter switch-off with +UB or 0 V at pin 4 (emitter)
Function input	Range input activation from 1.6 m (or 2 m in case of option /35) with +UB or 0 V on pin 2 (emitter) Teach-In input for programming on pin 8 (receiver)

Output

Pre-fault indication output	Stability Control (SC) 1 PNP, short-circuit protected, reverse polarity protected on pin 2 (receiver)
Switching type	Factory setting: dark on , Switchable to light-on mode
Signal output	Switch output (detection field C/Q) 1 push-pull (4 in 1) output, short-circuit protected, reverse polarity protected on pin 4 (receiver), Height monitoring (H1, H2, H3) 3 push-pull (4 in 1) outputs, short-circuit proof, reverse polarity protected on pin 5, pin 6, pin 7 (receiver)
Switching threshold	Factory setting: The signal tracking for the threshold value is deactivated, increasing the optical resolution by a maximum of 4 mm; switchable to active signal tracking
Switching voltage	max. 30 V DC

Switching current	max. 100 mA
Voltage drop	≤ 2 V DC
Switching frequency	max. 118 Hz, see datasheet
Response time	See chapter 10.3
Timer function	Off-delay programmable from 0 ... 1.25 s in 5 ms steps (adjustment via IO-Link only)

Conformity

Communication interface	IEC 61131-9
Product standard	EN 60947-5-2

Approvals and certificates

Protection class	III (IEC 61140)
UL approval	cULus Listed
CCC approval	CCC approval / marking not required for products rated ≤36 V

Ambient conditions

Ambient temperature	Standard : -10 ... 60 °C (14 ... 140 °F) Option /146: -30 ... 60 °C (-22 ... 140 °F)
Storage temperature	-30 ... 70 °C (-22 ... 158 °F)

Mechanical specifications

Conductor cross section	min. 0.25 mm ²
Housing length L	See chapter 10.4
Degree of protection	IP67
Connection	Emitter: connecting cable with 4-pin, M12 x 1 connector , 330 mm total length Receiver: connecting cable with 8-pin, M12 x 1 connector , 350 mm total length
Material	
Housing	extruded aluminum section , Silver anodized
Optical face	Plastic pane , Polycarbonate
Mass	See chapter 10.4
Cable length	max. 30 m

10.2 Type Code

Automation light grids from the LGS series are designated using a code as follows:

LGSxx-yyyy-IO/Options

Here, **xxx** indicates the resolution, **yyyy** indicates the height of the detection field, **IO** indicates the integrated IO interface, and **Options** indicates additional options.

Resolution [mm]	Detection field [mm]	IO-Link interface	Options
xxx	yyyy	IO	/35/110/115b/146
8	100, 300, ... 2100	IO	/35/110/115b/146
17	100, 300, ... 3200	IO	/35/110/115b/146
25	100, 300, ... 3200	IO	/35/110/115b/146
50	300, 600, ... 3000	IO	/35/110/115b/146
100	300, 600, ... 3000	IO	/35/110/115b/146

Clarification of Options

/35	Increased detection range: 8 m instead of 6 m
/110	Push-pull 0.1 A switching output, short-circuit proof, protected against reverse polarity (series)
/115b	M12 plug with 200 mm connection cable (series)
/146	Extended temperature range: -30 °C instead of -10 °C

10.3 Response Times and Number of Beams

The mechanical beam spacing determines the minimum detectable object size (signal tracking active). By crossing the light beams, the resolution of the light grid increases by a maximum of 100 %. The increased resolution is available in the area between 25 % ... 75 % of the detection range between the emitter strip and the receiver strip. Make sure that all objects pass the emitter strip or receiver strip at this distance. The crossover function is activated by default. Deactivating the crossover function does not alter the response time.

Variants	Detection field [mm]	Number of beams	Response time [ms]			
			C/Q output without object parameterization		C/Q output with object parameterization Height control outputs H1, H2, H3	
			Typical	Maximum	Typical	Maximum
LGS8-100	100	13	3	4	5	7
LGS8-300	300	37	3	6	7	10

Variants	Detection field [mm]	Number of beams	Response time [ms]			
			C/Q output without object parameterization		C/Q output with object parameterization Height control outputs H1, H2, H3	
			Typical	Maximum	Typical	Maximum
LGS8-600	600	73	5	8	9	15
LGS8-900	900	109	6	11	11	19
LGS8-1200	1200	145	7	13	13	24
LGS8-1500	1500	181	8	15	16	28
LGS8-1800	1800	217	9	17	18	33
LGS8-2100	2100	253	10	20	20	37
LGS17-100	100	7	2	4	5	7
LGS17-300	300	19	3	5	6	8
LGS17-600	600	37	3	6	7	10
LGS17-900	900	55	4	7	8	13
LGS17-1200	1200	73	5	8	9	15
LGS17-1500	1500	91	5	10	10	17
LGS17-1800	1800	109	6	11	11	19
LGS17-2100	2100	127	6	12	12	22
LGS17-2400	2400	145	7	13	13	24
LGS17-2700	2700	163	7	14	15	26
LGS17-3000	3000	181	8	15	16	28
LGS17-3100	3100	187	8	16	16	29
LGS17-3200	3200	193	8	16	16	30
LGS25-100	100	5	2	4	5	6
LGS25-300	300	13	3	5	5	7

Variants	Detection field [mm]	Number of beams	Response time [ms]			
			C/Q output without object parameterization		C/Q output with object parameterization Height control outputs H1, H2, H3	
			Typical	Maximum	Typical	Maximum
LGS25-600	600	25	3	5	6	9
LGS25-900	900	37	3	6	7	10
LGS25-1200	1200	49	4	7	7	12
LGS25-1500	1500	61	4	8	8	13
LGS25-1800	1800	73	5	8	9	15
LGS25-2100	2100	85	5	9	10	16
LGS25-2400	2400	97	5	10	10	18
LGS25-2700	2700	109	6	11	11	19
LGS25-3000	3000	121	6	11	12	21
LGS25-3100	3100	125	6	12	12	21
LGS25-3200	3200	129	6	12	12	22
LGS50-300	300	7	3	4	5	7
LGS50-600	600	13	3	5	5	7
LGS50-900	900	19	3	5	6	8
LGS50-1200	1200	25	3	5	6	9
LGS50-1500	1500	31	3	6	6	10
LGS50-1800	1800	37	3	6	7	10
LGS50-2100	2100	43	4	7	7	11
LGS50-2400	2400	49	4	7	7	12

Variants	Detection field [mm]	Number of beams	Response time [ms]			
			C/Q output without object parameterization		C/Q output with object parameterization Height control outputs H1, H2, H3	
			Typical	Maximum	Typical	Maximum
LGS50-2700	2700	55	4	7	8	13
LGS50-3000	3000	61	4	8	8	13
LGS100-300	300	4	2	4	5	6
LGS100-600	600	7	2	4	5	7
LGS100-900	900	10	3	5	5	7
LGS100-1200	1200	13	3	5	5	7
LGS100-1500	1500	16	3	5	5	8
LGS100-1800	1800	19	3	5	6	8
LGS100-2100	2100	22	3	5	6	9
LGS100-2400	2400	25	3	5	6	9
LGS100-2700	2700	28	3	6	6	9
LGS100-3000	3000	31	3	6	6	10

Table 10.1 Response times with and without object parameterization

10.4 Profile length and weight

Profile length and weight

Detection field [mm]	Overall length of the transmitter / receiver strip [mm]	Weight of transmitter / receiver strip [g]
100	260	200
200	360	250
300	460	300
400	560	350
500	660	400
600	760	450
700	860	500
800	960	550
900	1060	600
1000	1160	650
1100	1260	700
1200	1360	750
1300	1460	800
1400	1560	850
1500	1660	900
1600	1760	950
1700	1860	1000
1800	1960	1050
1900	2060	1100
2000	2160	1150
2100	2260	1200
2200	2360	1250
2300	2460	1300
2400	2560	1350
2500	2650	1400
2600	2760	1450
2700	2860	1500
2800	2960	1550
2900	3060	1600
3000	3160	1650

239596 2021-03

Detection field [mm]	Overall length of the transmitter / receiver strip [mm]	Weight of transmitter / receiver strip [g]
3100	3260	1700
3200	3360	1750



Table 10.2 Profile length and weight per strip

10.5 Accessories

10.5.1 Installation accessories

The following products are available as mounting accessories:

Compatible mounting accessories for the light grid

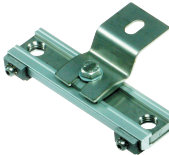
No.	Designation	Illustration	Description
1	OMH-SLCT-01		Mounting bracket
2	OMH-LGS-01 Only in combination with OMH-SLCT-01		Mounting bracket
3	OMH-SLCT-03		Mounting bracket



No.	Designation	Illustration	Description
4	OMH-SLCT-04		Mounting bracket
5	OMH-SLCT-05		Mounting bracket
6	AA SLCT-01		Profile alignment tool

Table 10.3 Accessories list

10.5.1.1 Mounting Aid OMH-SLCT-01

Model number: OMH-SLCT-01

The emitters/receivers can be secured using mounting aids that grip the dovetail guide. There are dovetail guides on three sides of the profile. When mounting and aligning the unit, avoid subjecting the profile to mechanical tension.

A minimum of two mounting aids must be used to secure the emitter or receiver. If vibrations or shocks are expected, we recommend attaching mounting aids at intervals of 500 mm.

10.5.1.2 Mounting Aid OMH-LGS-01

Model number: OMH-LGS-01

The OMH-LGS-01 mounting aid acts as a fixed bearing and secures the position of the light curtain in the event of thermal expansion, mechanical vibration, or shock.

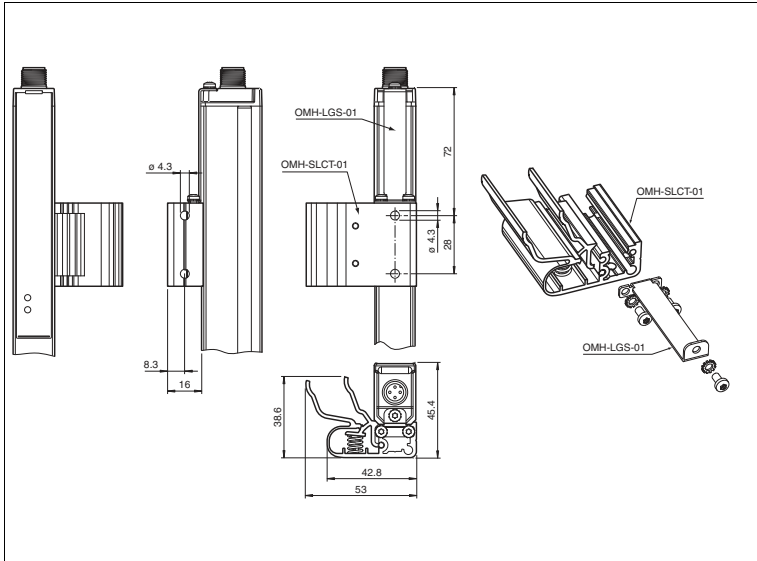

Figure 10.1 Dimensional drawing and fitting mounting accessory OMH-LGS-01

10.5.1.3

Alignment aid

Order code: AA-SLCT-01

The transmitter and receiver should always be aligned at the same height in parallel to one another. The AA-SLCT-01 alignment aid with bubble level assists the perpendicular alignment of the profile. The AA-SLCT-01 alignment aid is simply clipped into the groove on the side of the profile.

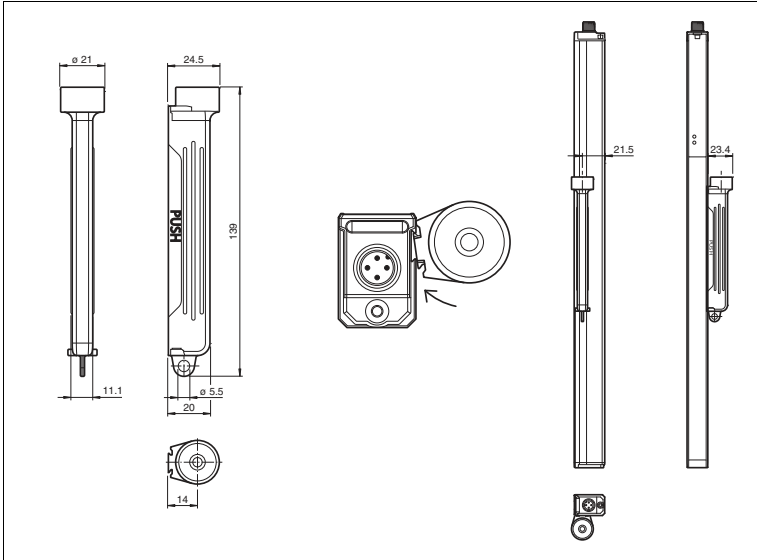

Figure 10.2 Dimensional drawing and assembly of the alignment AA-SLCT-01

10.5.2 Connecting Cables

Various 4-pin and 8-pin connecting cables are available in different cable lengths.

Connecting cables for automation light grids

Use	Model number			
	Length 2 m	Length 5 m	Length 10 m	Length 15 m
4-pin cable (transmitter strip)	V1-G-BK2M-PUR-UL	V1-G-BK5M-PUR-UL	V1-G-BK10M-PUR-UL	V1-G-BK15M-PUR-UL
8-pin cable (receiver strip)	V19-G-BK2M-PUR-IEC	V19-G-BK5M-PUR-IEC	V19-G-BK10M-PUR-IEC	

10.5.3 Accessories for IO-Link Operation

The following accessories are available for operating the receiver strip in IO-Link mode.

Designation	Description
IO-Link-Master02-USB	IO-Link master parameterization tool
V19-G-BK2M-PUR-U-V1-G	Adapter cable for offline parameterization M12 x 1, 8-pin to M12 x 1, 4-pin, length 2 m

239596 2021-03

Designation	Description
IO Device Description	Device description on how to operate and control automation light grids via an IO-Link master (available as a download on the product page)
IO Device Description Interpreter	IO Device Description interpreter and device type manager for use via IO Device Description within an FDT environment

10.6 Parameterizing the light grid

Parameterizing the light grid using a flow chart.

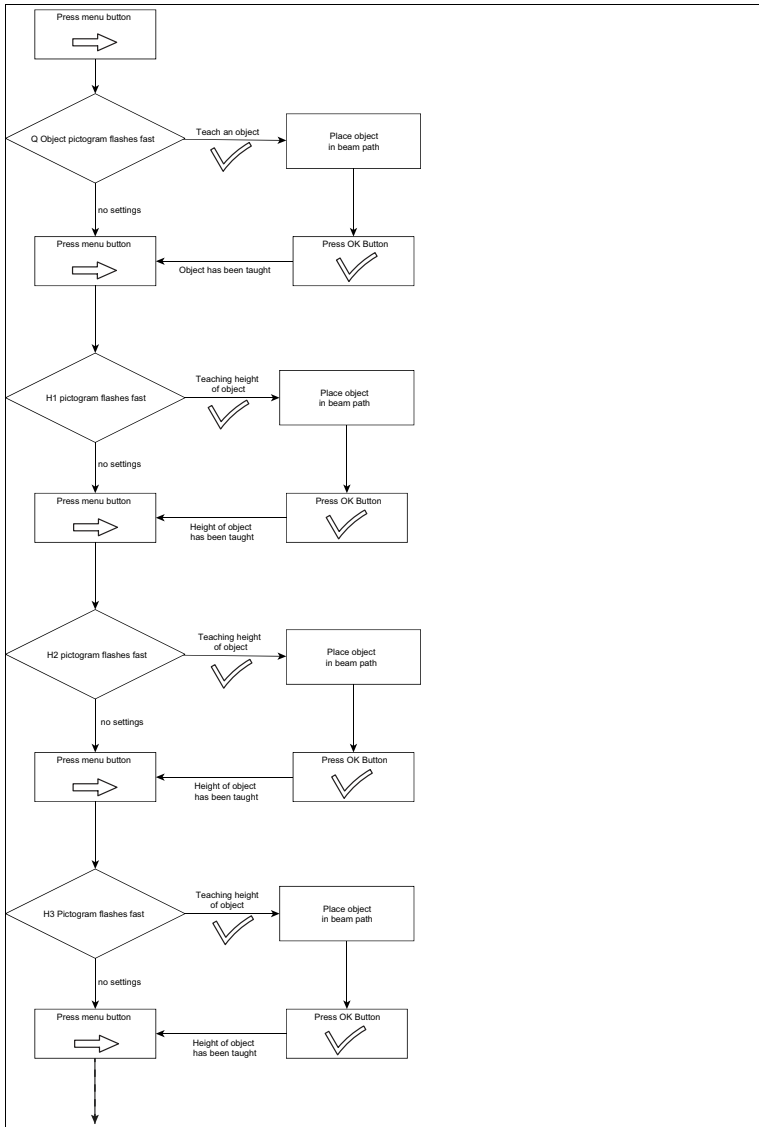

Figure 10.3 Parameterizing the light grid using a flow chart, left page

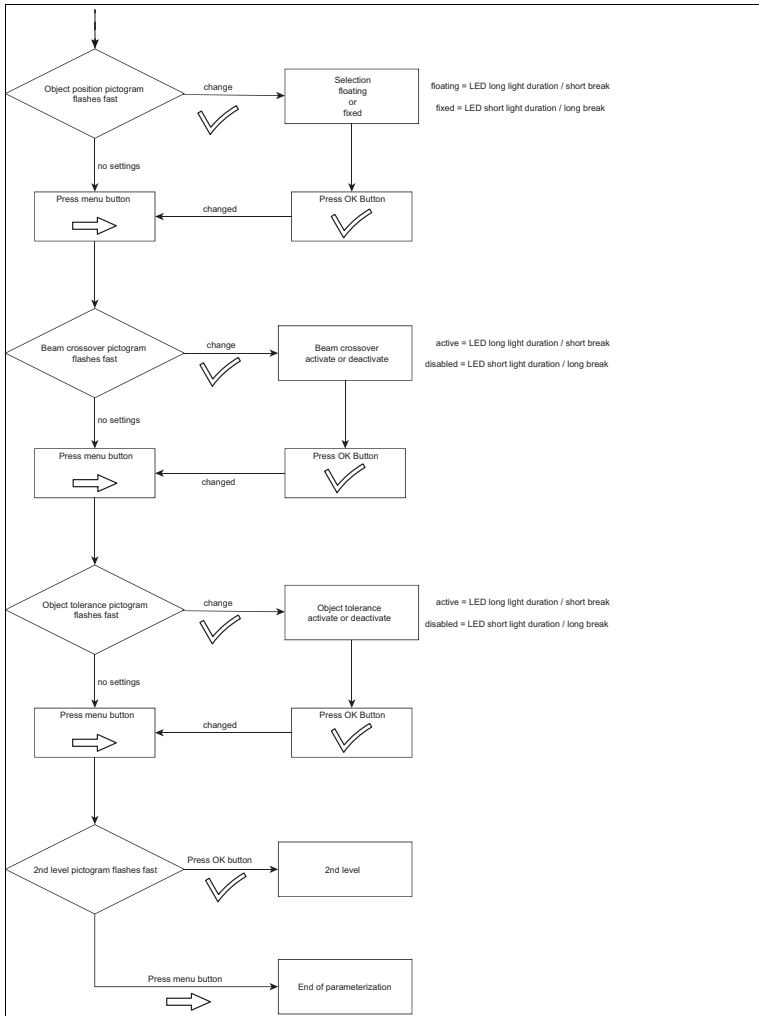

Figure 10.4 Parameterizing the light grid using a flow chart, right page

Your automation, our passion.

Explosion Protection

- Intrinsic Safety Barriers
- Signal Conditioners
- FieldConnex® Fieldbus
- Remote I/O Systems
- Electrical Ex Equipment
- Purge and Pressurization
- Industrial HMI
- Mobile Computing and Communications
- HART Interface Solutions
- Surge Protection
- Wireless Solutions
- Level Measurement

Industrial Sensors

- Proximity Sensors
- Photoelectric Sensors
- Industrial Vision
- Ultrasonic Sensors
- Rotary Encoders
- Positioning Systems
- Inclination and Acceleration Sensors
- Fieldbus Modules
- AS-Interface
- Identification Systems
- Displays and Signal Processing
- Connectivity

Pepperl+Fuchs Quality
Download our latest policy here:

www.pepperl-fuchs.com/quality

