

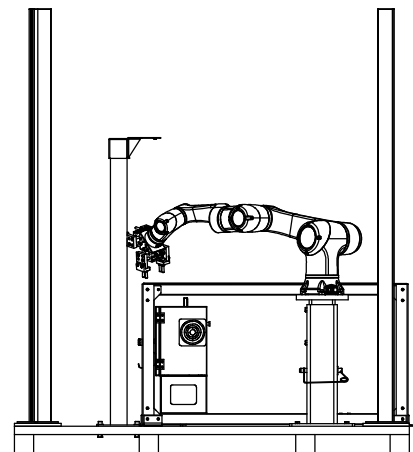

- TABLE, PEDESTAL, PART FLIP STATION AND LIGHT CURTAINS CAN BE MOUNTED ANYWHERE. LAYOUT DIMS PROVIDED IN THIS DOCUMENT ARE **FOR REFERENCE ONLY**. MEASURE YOUR MACHINE AND APPLICATION USE THE PROVIDED 3D MODELS TO DETERMINE THE BEST LAYOUT.
- THE WOOD PALLET INCLUDED WITH OUR COBOT PACKAGE IS A GREAT WAY TO PROVE OUT YOUR CELL LAYOUT. DECIDING WHERE TO MOUNT EACH PIECE MAY REQUIRE SOME EXPERIMENTATION, BUT ADJUSTING THE COMPONENTS ON THE WOOD PALLET IS EASY. ONCE YOU'RE SATISFIED WITH THE LAYOUT, **WE RECOMMEND MOUNTING EVERYTHING MORE PERMANENTLY TO THE SHOP FLOOR.**

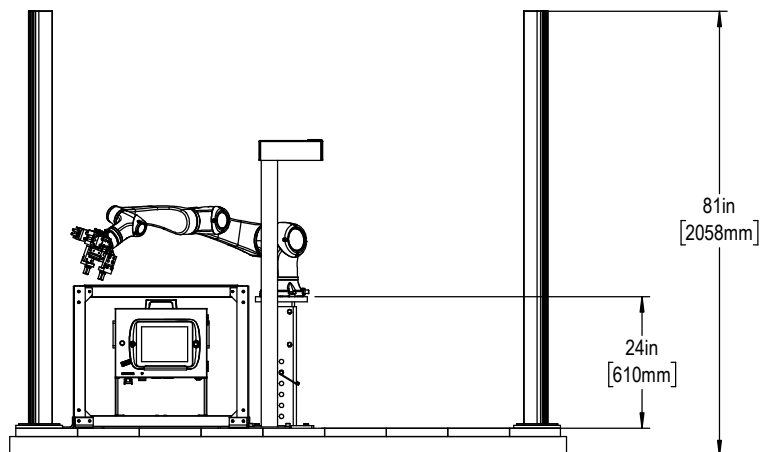
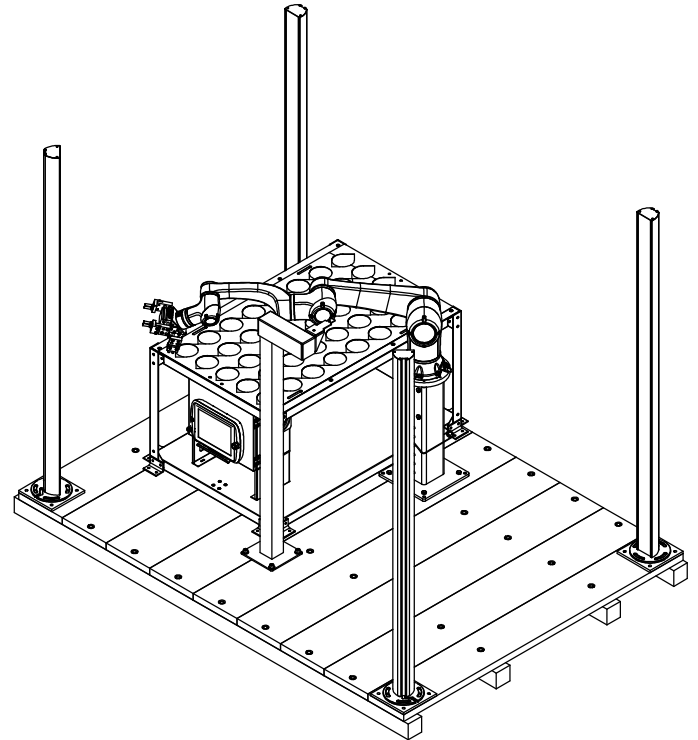
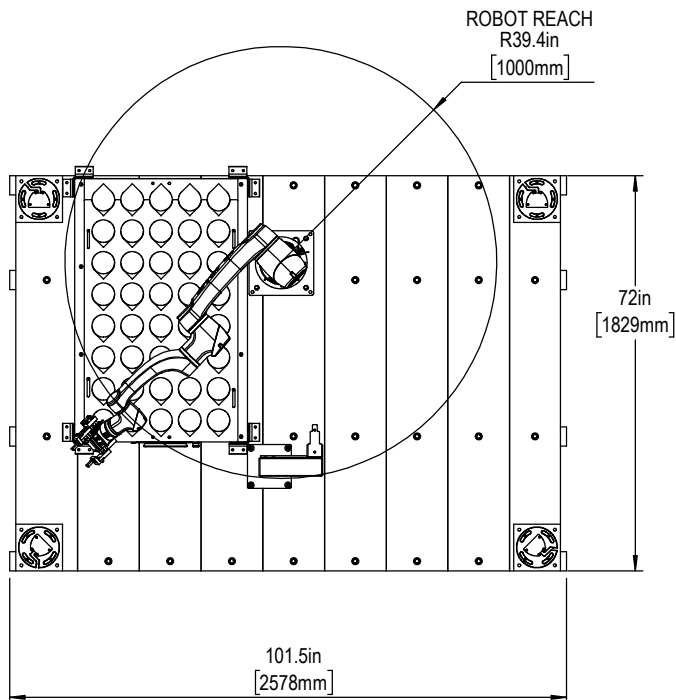

ST-10 SHOWN. ALL DIMS **FOR REFERENCE ONLY.**

08-1940 IS A MODULAR KIT. COMPONENT PLACEMENT WILL VARY BASED ON CUSTOMER APPLICATION AND RISK ASSESMENT

ENSURE THE FOLLOWING:

1. ROBOT IS CAPABLE OF REACHING MILL WORKHOLDING AND ALL OF PARTS TABLE
2. THE COBOT JOINTS MUST NOT BE IN LINE WITH EACH OTHER.
3. LIGHT CURTAIN PLACEMENT MUST NOT INTERFERE WITH CONTROLLER, OPERATOR MUST BE ABLE TO REACH CYCLE START OR RJH WITHOUT BREAKING LIGHT CURTAIN. RELOCATING THE RJH MAY BE NECESSARY. OPERATOR SHOULD NOT BE ABLE TO START ROBOT PROGRAM WHILE INSIDE LIGHT CURTAIN.
4. AUTO-WINDOW AND HANDLE MUST CLEAR SETUP
5. AUTO-DOOR AND HANDLE MUST CLEAR SETUP. MACHINES EQUIPPED WITH A PARTS CATCHER REQUIRE EXTRA CLEARANCE

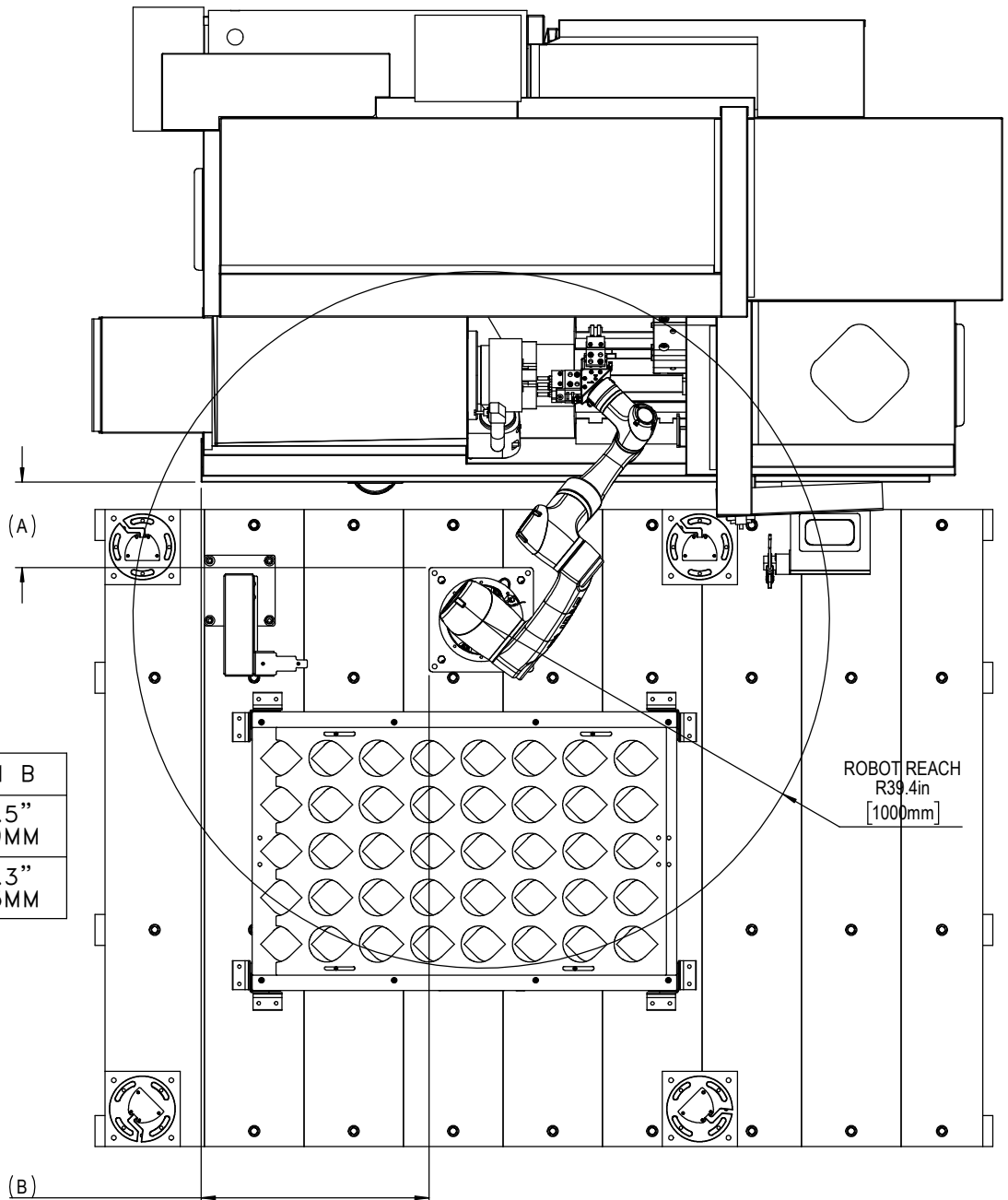

LATHE	DIM A	DIM B
ST-10/15	9.65" 245MM	25.5" 649MM
ST-20/25	8.18" 208MM	31.3" 795MM

ROBOT REACH  
R39.4in  
[1000mm]

VF-2 SHOWN. ALL DIMS FOR REFERENCE ONLY.

08-1940 IS A MODULAR KIT. COMPONENT PLACEMENT WILL VARY BASED ON CUSTOMER APPLICATION AND RISK ASSESSMENT

ENSURE THE FOLLOWING:

1. ROBOT IS CAPABLE OF REACHING MILL WORKHOLDING AND ALL OF PARTS TABLE
2. THE COBOT JOINTS MUST NOT BE IN LINE WITH EACH OTHER.
3. LIGHT CURTAIN PLACEMENT MUST NOT INTERFERE WITH CONTROLLER, OPERATOR MUST BE ABLE TO REACH CYCLE START OR RJH WITHOUT BREAKING LIGHT CURTAIN. RELOCATING THE RJH MAY BE NECESSARY. OPERATOR SHOULD NOT BE ABLE TO START ROBOT PROGRAM WHILE INSIDE LIGHT CURTAIN.
4. AUTO-DOOR AND HANDLE MUST CLEAR SETUP

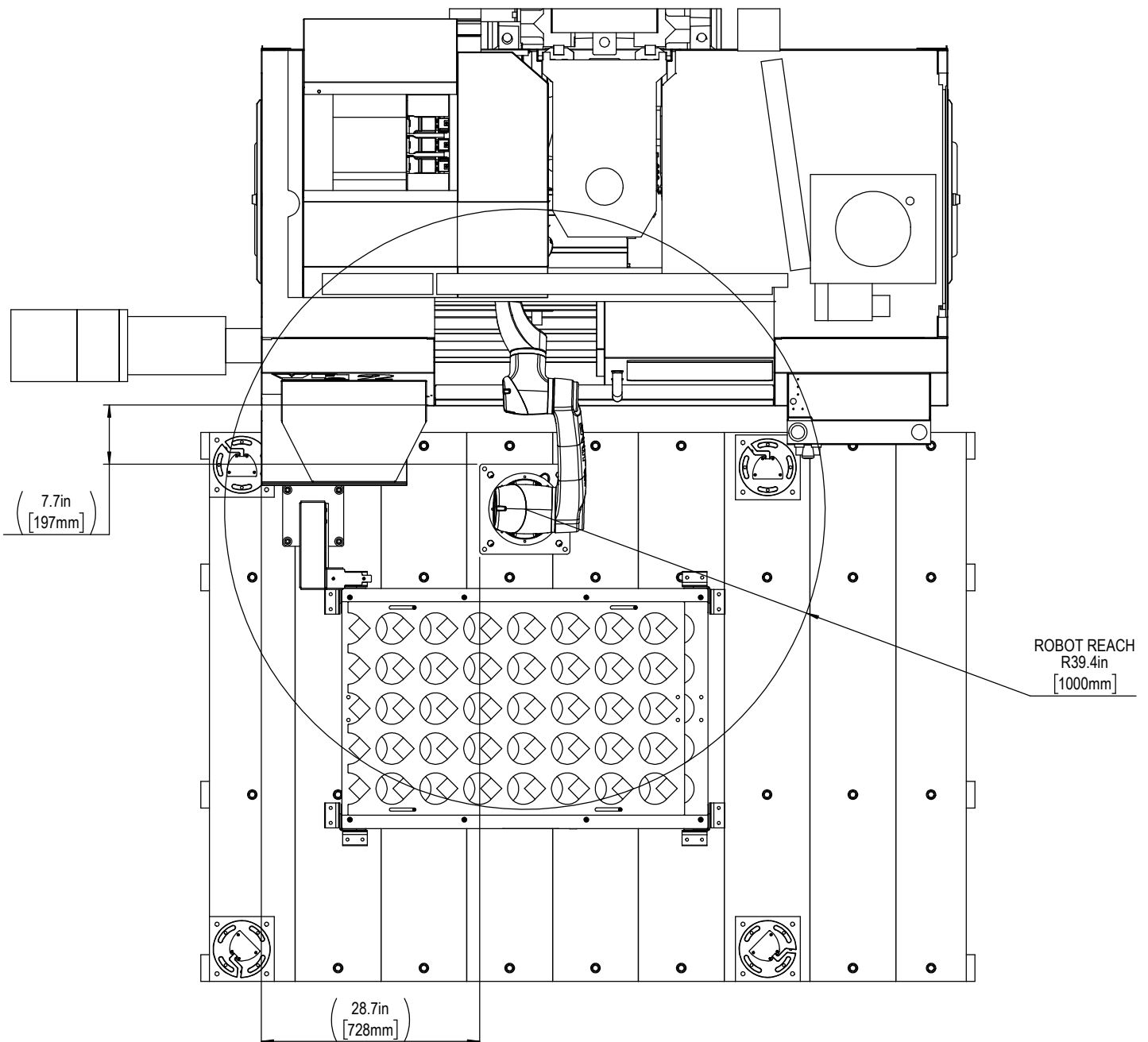

UMC-500 LOADING THROUGH SIDE WINDOW SHOWN. ALL DIMS **FOR REFERENCE ONLY**.  
08-1940 IS A MODULAR KIT. COMPONENT PLACEMENT WILL VARY BASED ON CUSTOMER APPLICATION AND RISK ASSESSMENT

ENSURE THE FOLLOWING:

1. ROBOT IS CAPABLE OF REACHING MILL WORKHOLDING AND ALL OF PARTS TABLE
2. THE COBOT JOINTS MUST NOT BE IN LINE WITH EACH OTHER.
3. LIGHT CURTAIN PLACEMENT MUST NOT INTERFERE WITH CONTROLLER, OPERATOR MUST BE ABLE TO REACH CYCLE START OR RJH WITHOUT BREAKING LIGHT CURTAIN. RELOCATING THE RJH MAY BE NECESSARY. OPERATOR SHOULD NOT BE ABLE TO START ROBOT PROGRAM WHILE INSIDE LIGHT CURTAIN.
4. AUTO-WINDOW AND HANDLE MUST CLEAR SETUP

