

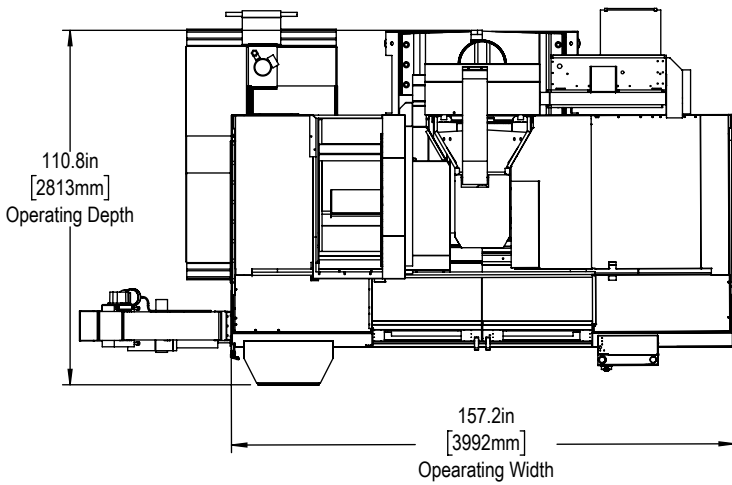

Installed Dimensions

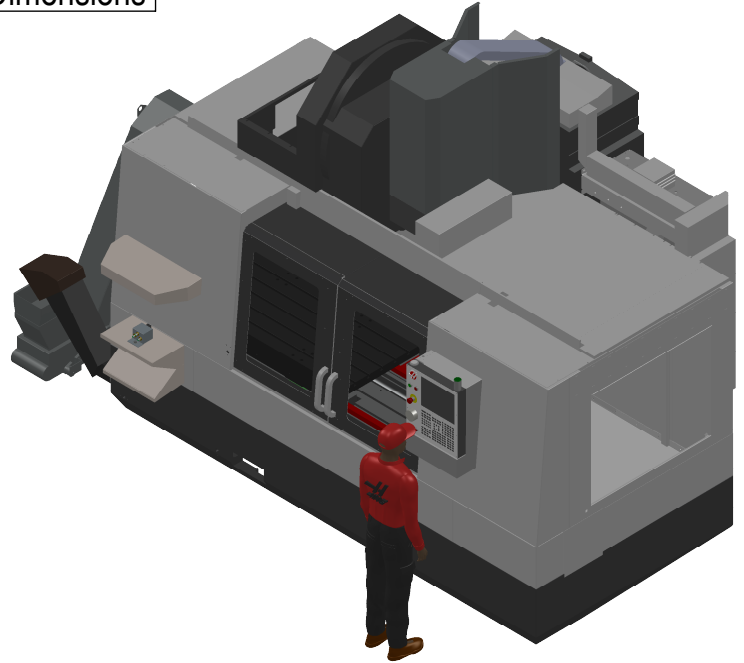

Leveling Pad Height

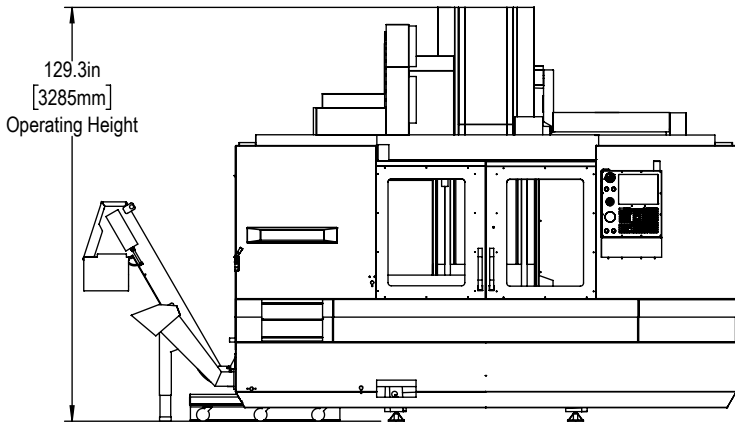
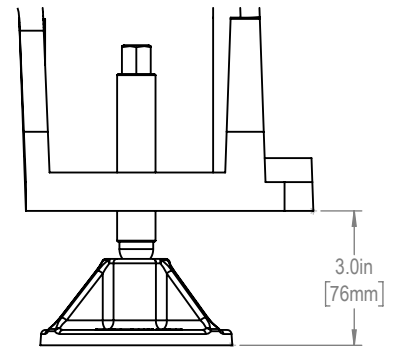

*All Height Dimensions Based on Suggested Leveling Pad Height

Shipping Dimensions

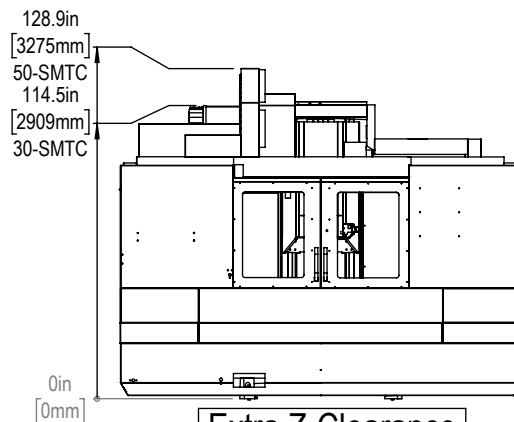
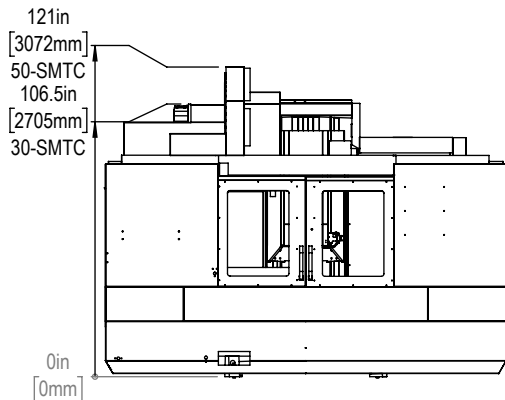

Extra Z-Clearance

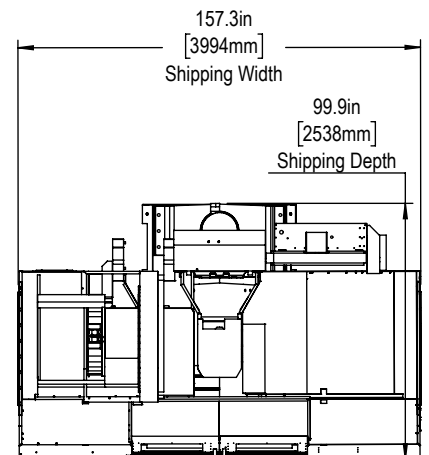

Air & Power

***Add 8in for Extended Z-Axis Clearance**

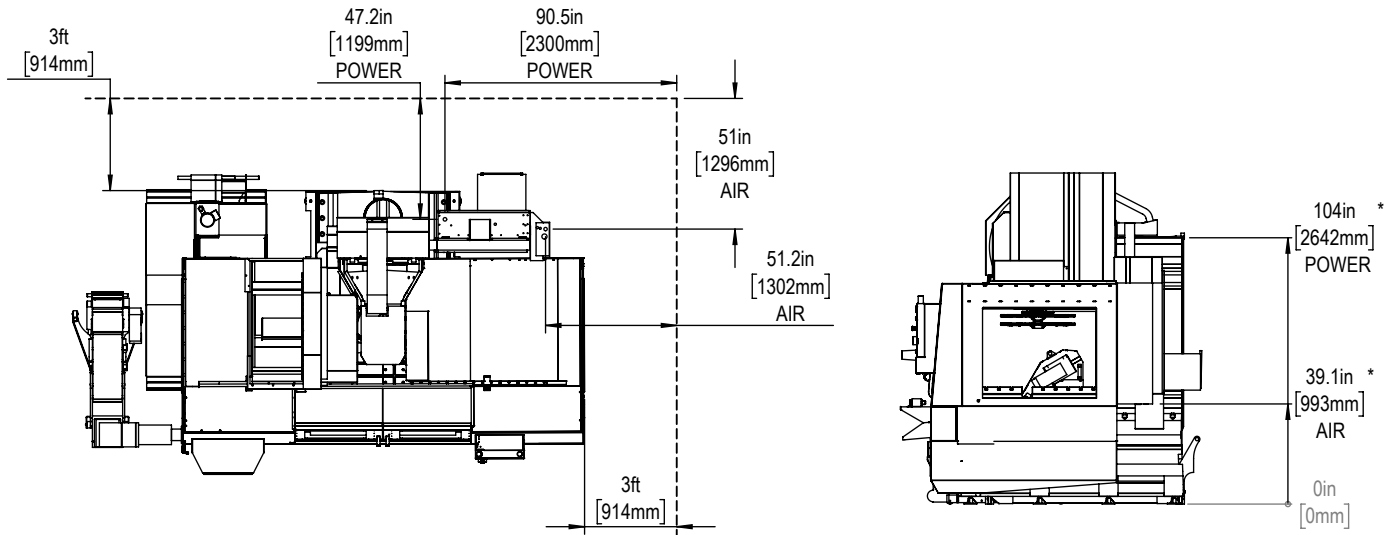

Maintain 3 feet [915mm] clearance to the nearest obstruction around all sides of machine perimeter for maintenance access

Note:
Machine must be placed on one continuous concrete slab. Slab should extend 12in [305mm] beyond anchor holes in all directions

Anchor Pattern

For machines built before Sept 2023.

Anchor Hole Detail
Ø0.625in
▽2.0in-2.25in

NOTE: For machines built after Sept. 2023, see separate Anchoring Template.

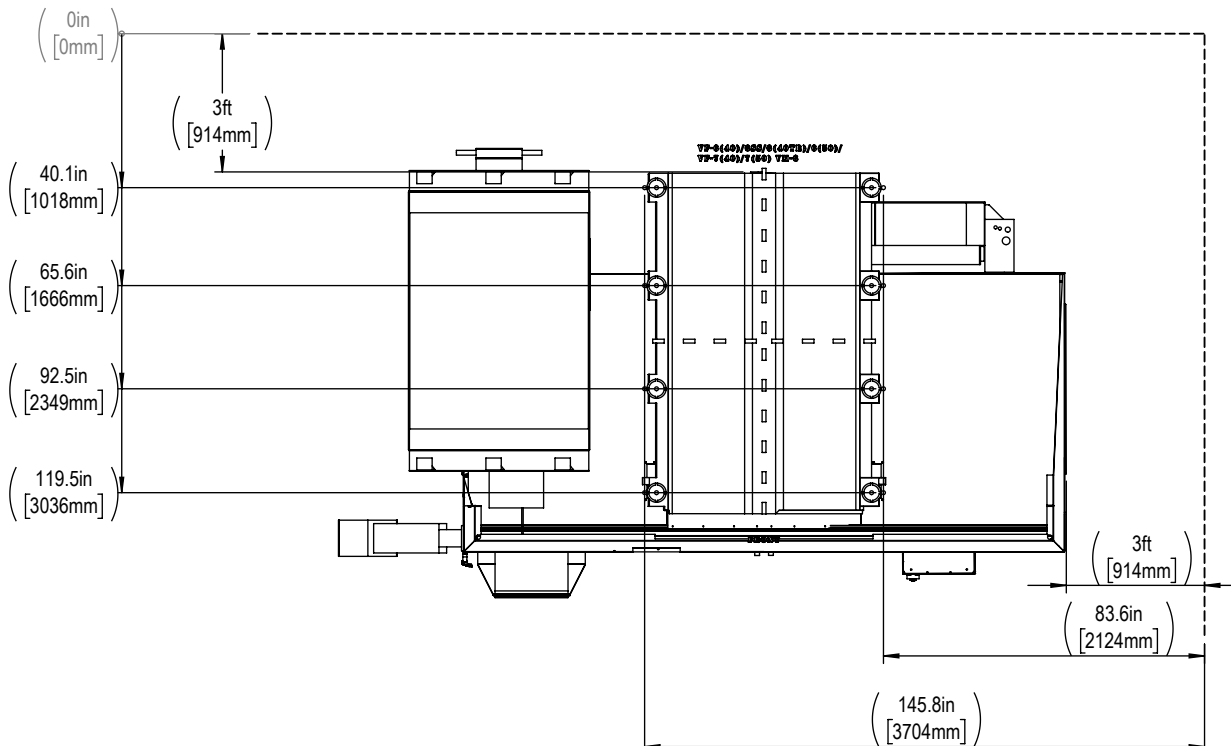

For precise locations and specifications please use template in Anchoring Kit found at Haascnc.com



Height Breakdown

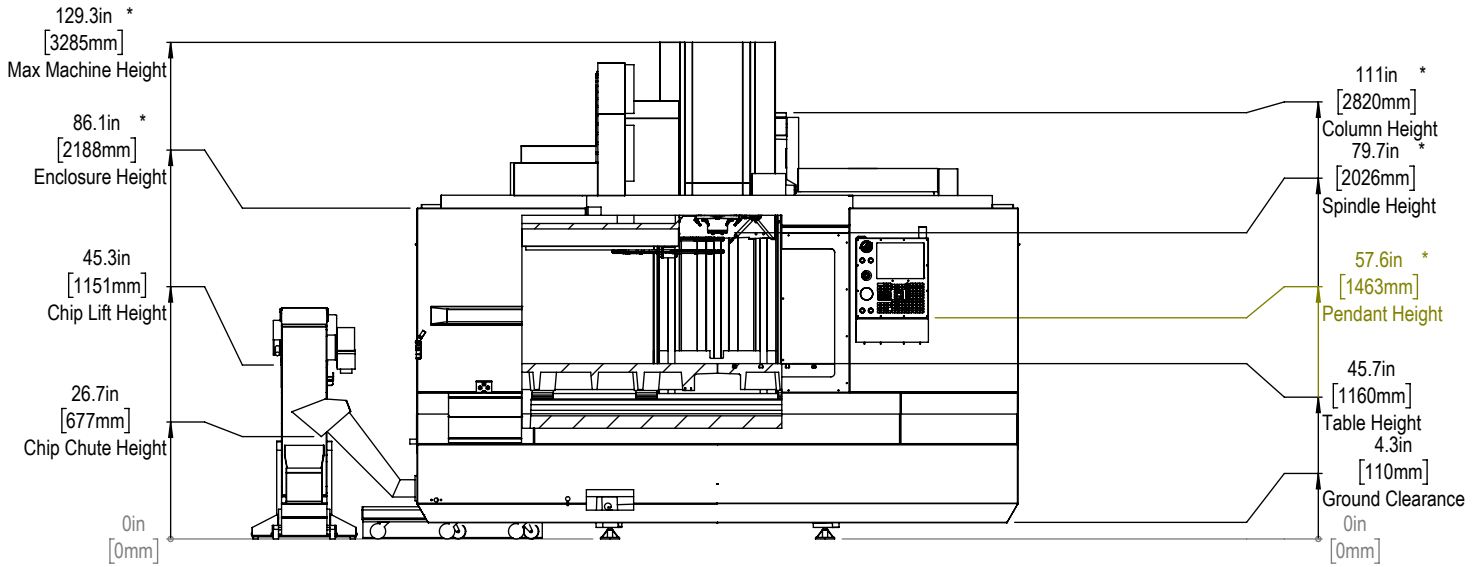

*Add 8in for Extended Z-Axis Clearance

Width Breakdown

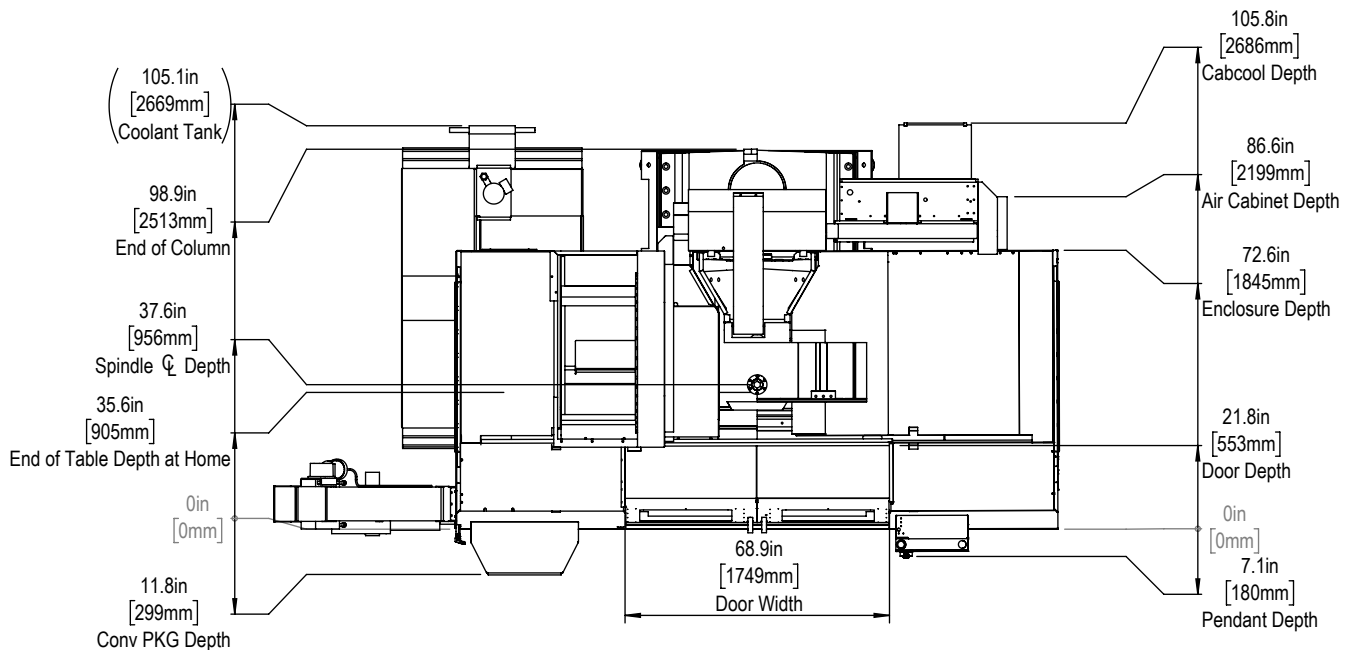

X&Y-Axis Travel and Clearance

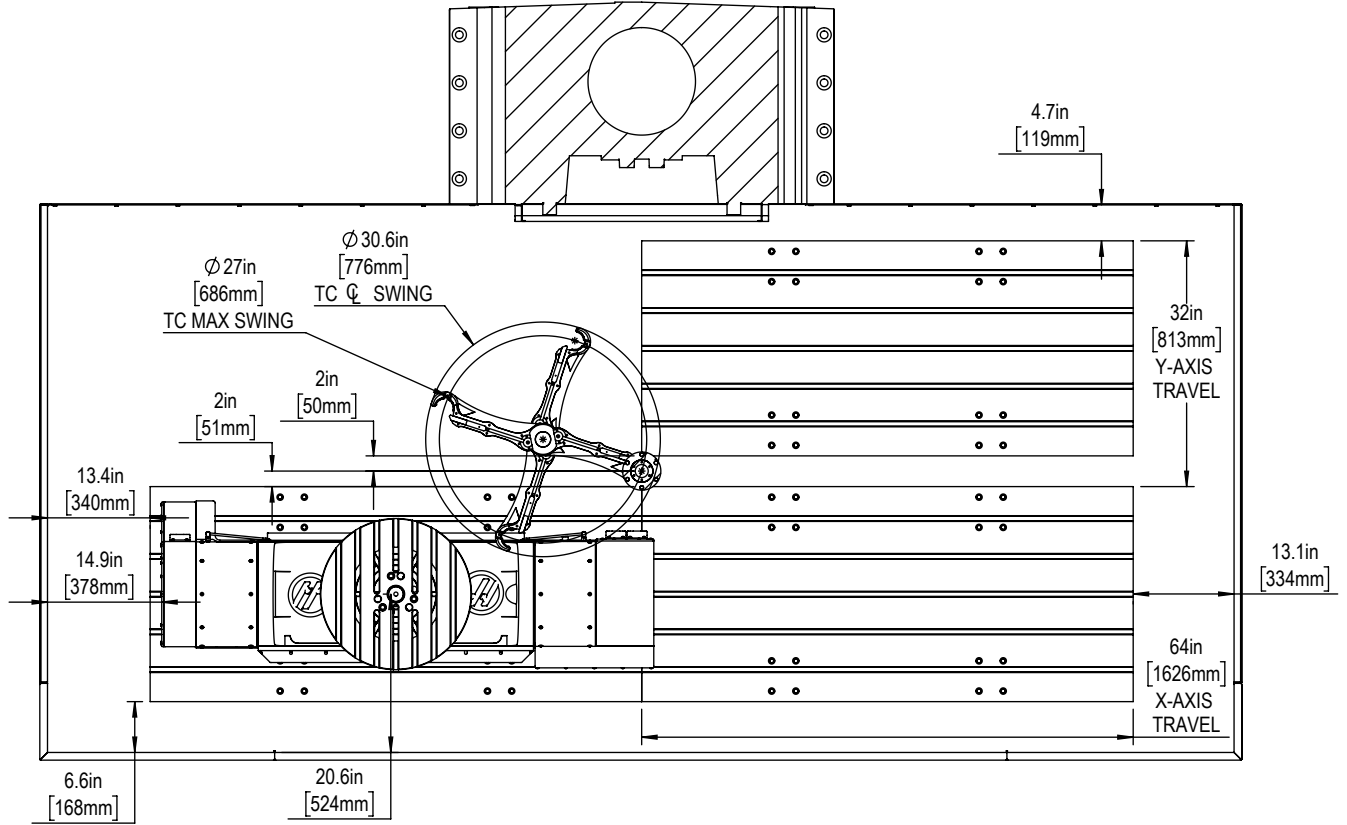

Z-Axis Travel and Clearance

With 8in EXTENDED Z-AXIS CLEARANCE

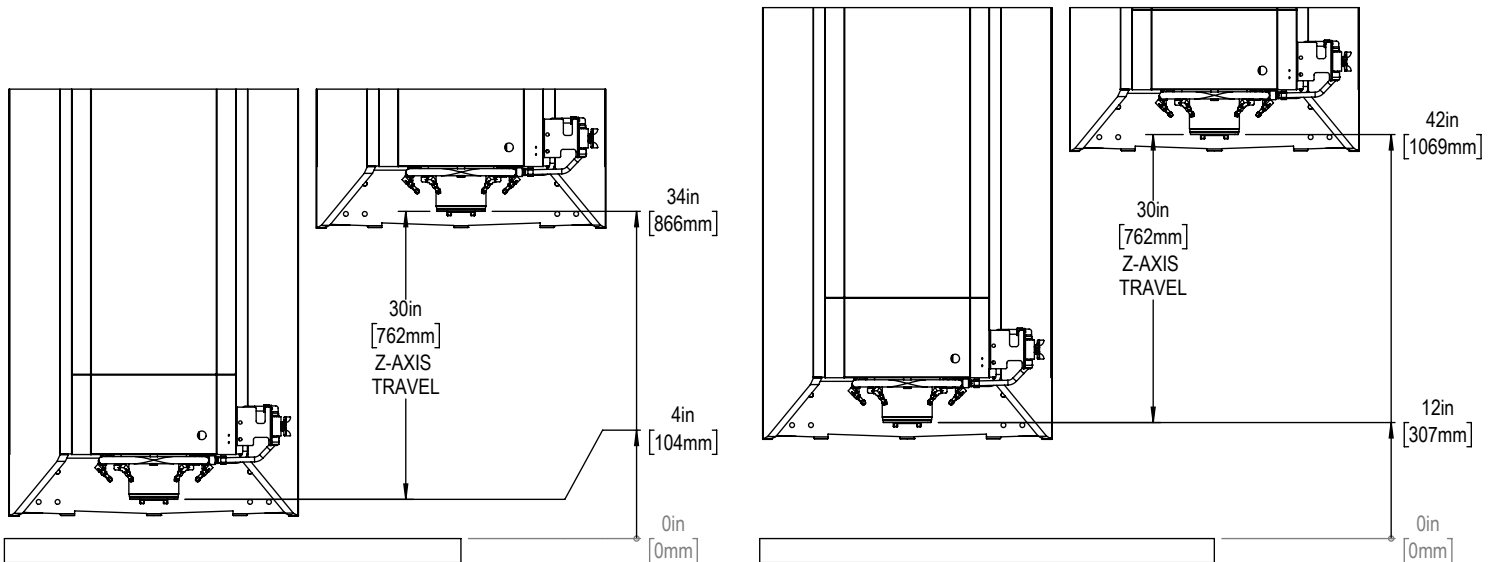



Optional Table With X T-Slots Only

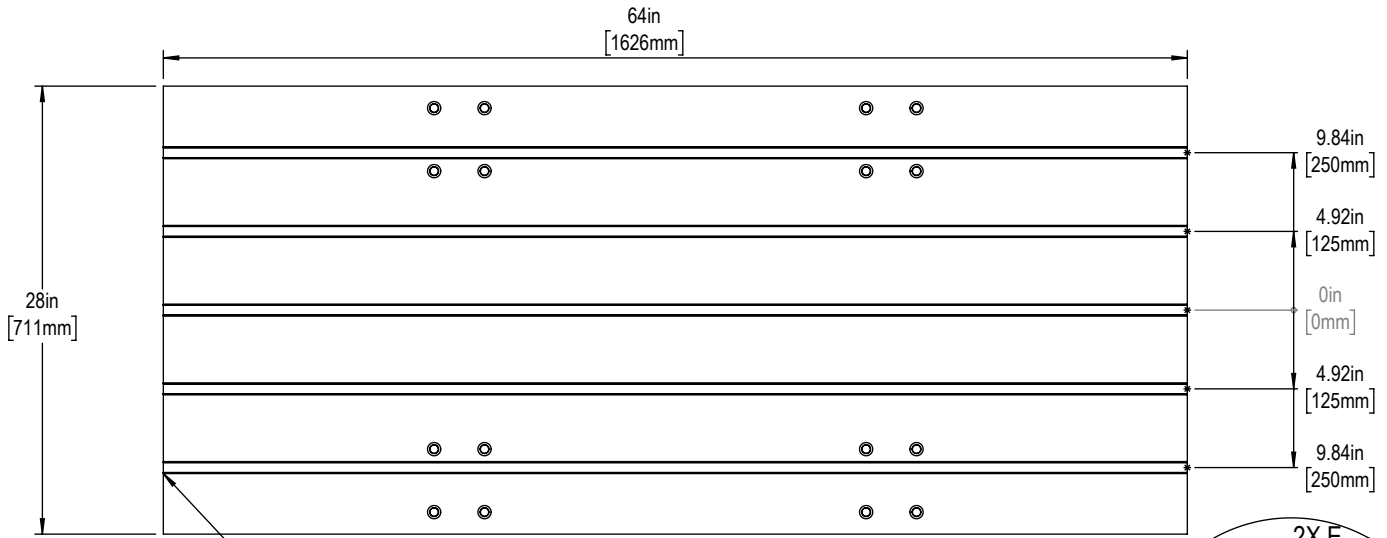

16mm T-Slots

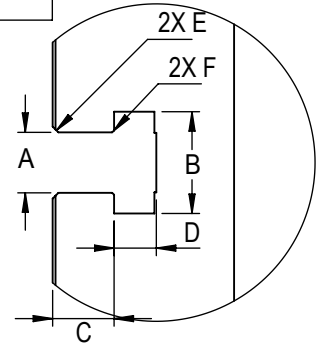

T-Slot Dimensions in inches

Slot Size	A	B	C	D	E	F
12mm	$0.438^{+0.002}_{-0.000}$	0.76 ± 0.02	0.310 ± 0.010	0.318 ± 0.010	$0.03 \times 45^\circ$	$0.020 \times 45^\circ$
16mm	0.628 ± 0.002	1.06 ± 0.02	0.640 ± 0.010	0.420 ± 0.010	$0.06 \times 45^\circ$	$0.020 \times 45^\circ$

Add 8in to all Dimensions for 8in Extended Z-Axis Clearance

Tool Changer

Drop Down Distance by Spindle Type:
50T = 6.56in
40T,30T,HSK-A63=4.56in

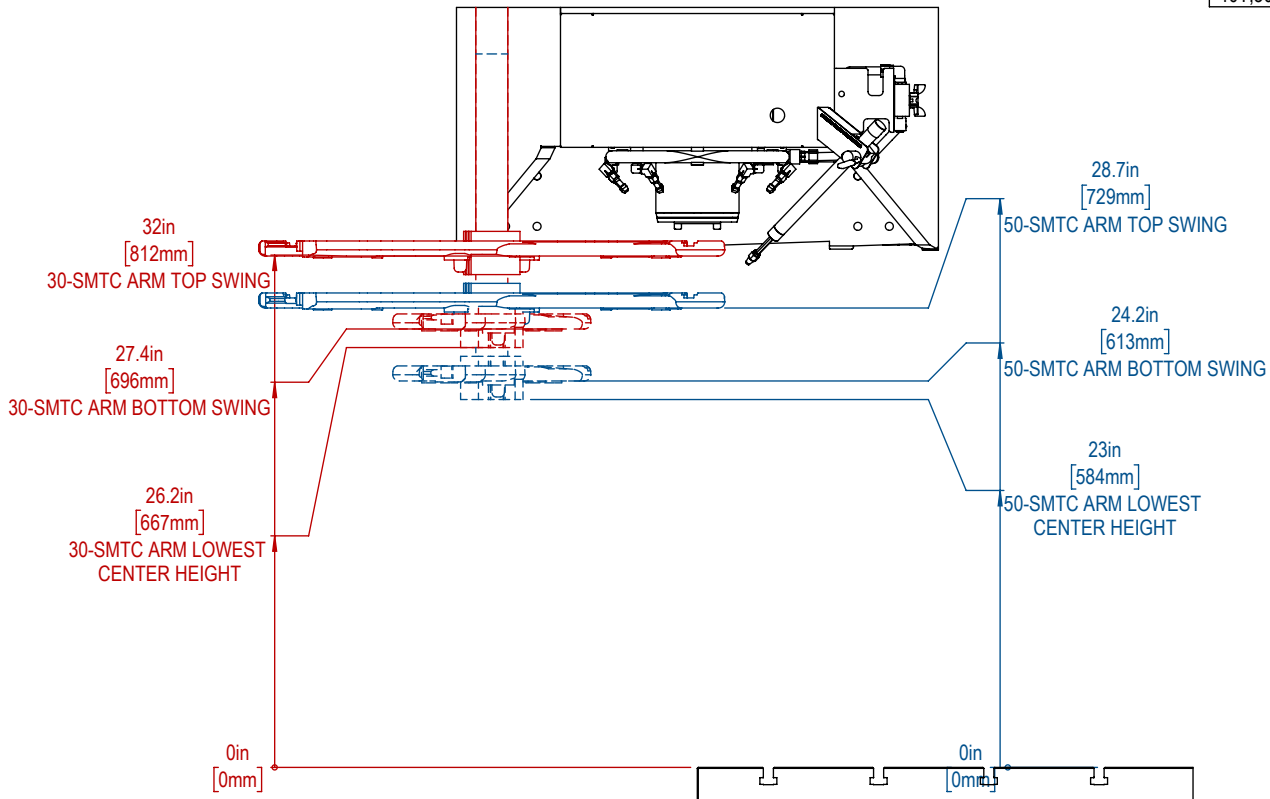

SINGLE PAGE

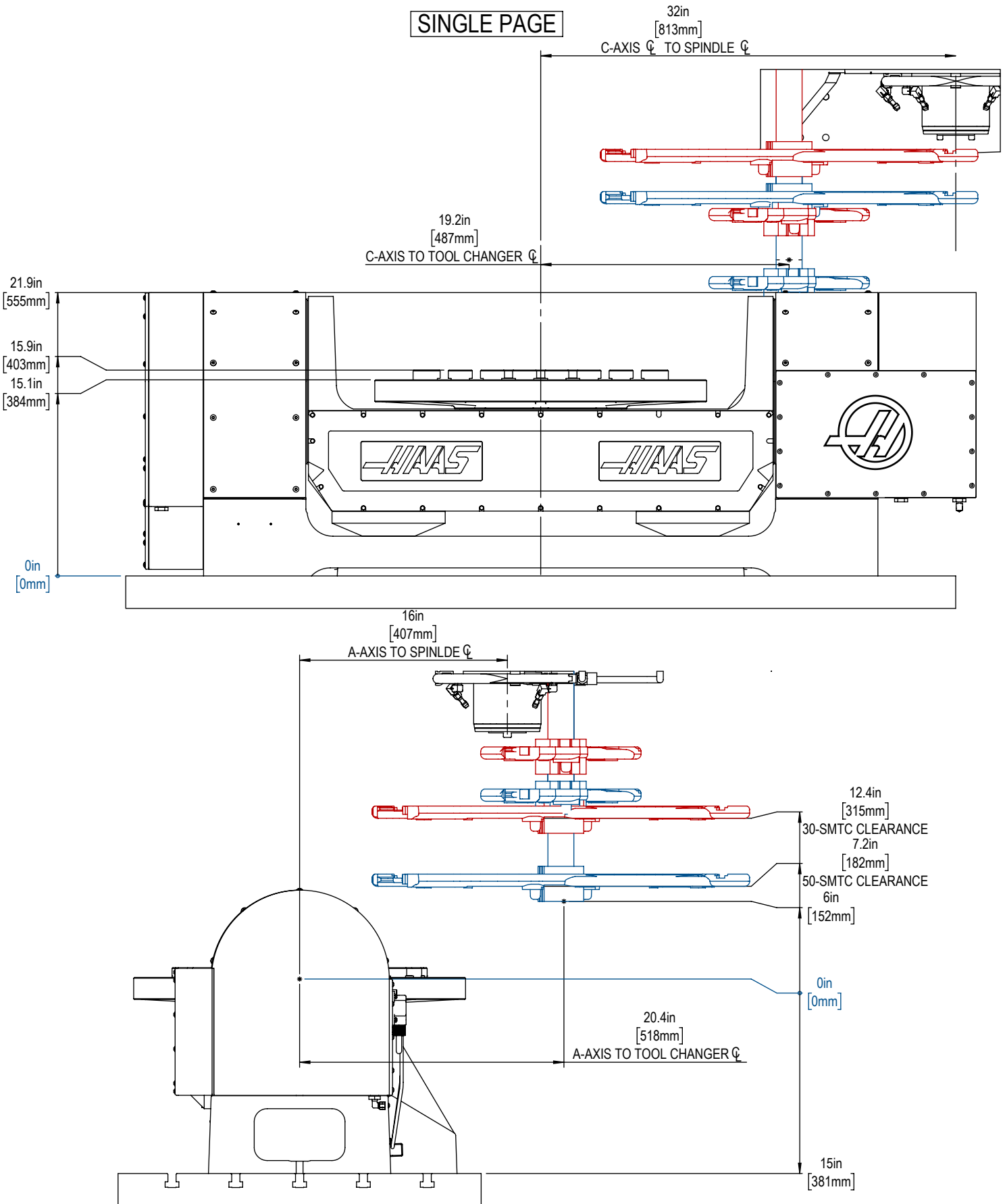

For more information please use the TR310 MLD found on Haascnc.com