



Haas
F1 Team
OFFICIAL MACHINE TOOL

F1 MILL

High-Performance Mill for Production and Prototyping



SMALL BUT MIGHTY

The CM-1 offers full VMC capabilities in an ultra-compact package that fits into just 6' x 7' (1.8 x 2.1 m) of floor space. But don't let the size fool you; the CM-1 can handle full production machining, and is perfect for cutting small, difficult parts. Add a Haas TRT70 dual-axis rotary to create a versatile 5-axis solution for small parts.

22.5" x 10" (572 x 254 mm) Table

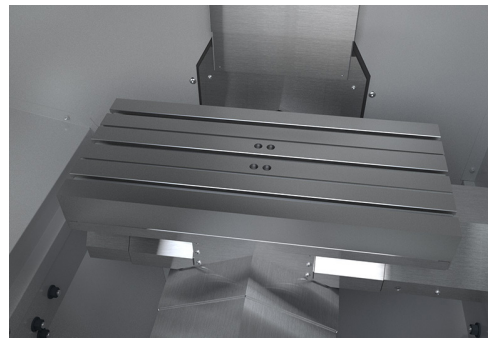

Toolholder Rack and Convenient Shelf



Haas Control Inputs



CM-1 SPECIFICATIONS



TRAVELS

• X Axis	12"	305 mm
• Y Axis	10"	254 mm
• Z Axis	14"	356 mm

SPINDLE

• Max Rating	5.0 hp	3.7 kW
• Max Speed	30,000 rpm	30,000 rpm
• Max Torque	8 ft-lbf @ 3000 rpm	10.8 Nm @ 3000 rpm
• Drive System	Direct Speed, Belt Drive	Direct Speed Belt Drive
• Taper	ISO 20	ISO 20

TABLE

• Length x Width	22.5" x 10"	572 mm x 254 mm
------------------	-------------	-----------------

TOOL CHANGER

• Capacity / Type	20 / Carousel	20 / Carousel
• Max Tool Diameter (full)	2.3"	58 mm
• Max Tool Weight	5 lb	2.3 kg
• Tool-to-Tool (avg)	3.2 s	3.2 s

FEEDRATES

• Max Cutting	500 ipm	12.7 m/min
• Rapids on X / Y / Z	757 ipm	19.2 m/min

GENERAL

• Coolant Capacity	13 gal	49 L
--------------------	--------	------

AIR REQUIREMENTS

• Air Required	1 scfm @ 100 psi	28 L/min @ 4.8 bar
----------------	------------------	--------------------

High-Accuracy Solution for Production and Prototyping

Small parts can pose significant machining challenges for the average job shop. Tiny holes, minute features, extreme accuracies, and fine surface finishes may prove difficult for larger machines. The CM-1 Compact Mill is a small-footprint, high-accuracy solution for producing and prototyping small, high-precision 2D and 3D parts, such as those found in the communications, aerospace, medical, and dental industries.

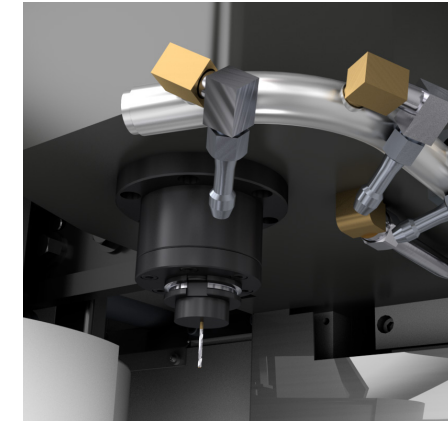

SPINDLE

The CM-1 Compact Mill comes standard with 30,000-rpm ISO 20 taper spindle. For applications that demand high surface speeds and very small tools, an optional 50,000-rpm spindle is available. All Haas spindles are designed and built in-house in our Southern California manufacturing facility.



MULTI-AXIS MACHINE

Adding a rotary axis to the CM-1 is the fastest way to boost throughput and increase accuracy. Adding our smallest dual-axis rotary enables quick positioning of parts to nearly any angle for 5-side (3+2) machining, or provides full simultaneous 5-axis motion for contouring and complex machining.

TRT70 / 1 / 70 mm / 60 ft-lb / 410 °/sec

Rotary Spindles Platter size Max torque Max speed

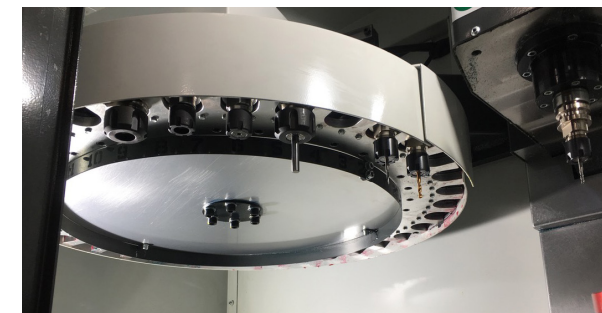
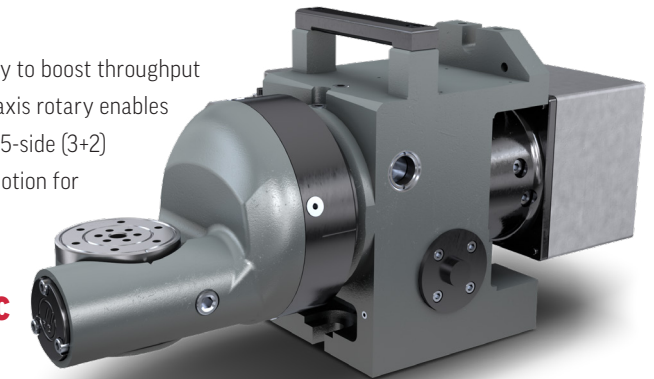

PROBING

Setup reduction is critical to maximizing the productivity of any machine tool. With the probing systems available from Haas, any machine can be set up in minutes, with just a few button pushes. Our industry-leading Wireless Intuitive Probing System (WIPS) sets the standard for integrated probing systems.

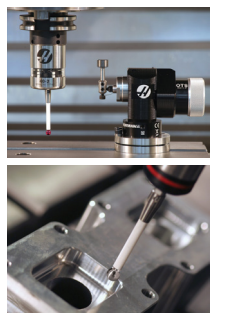

THE 36-POCKET TOOL CHANGER

The 36-pocket tool changer option for the CM-1 not only increases the machine's tool capacity, but also significantly improves the machine's enclosure. While the enclosure got wider to accommodate the larger tool carousel, the additional width allowed us to upgrade the door configuration. The door now mounts internally and slides open, rather than swinging open in a wide arc, like the previous design. We also were able to mount the standard tool rack and work table to the front of the enclosure for added operator convenience.

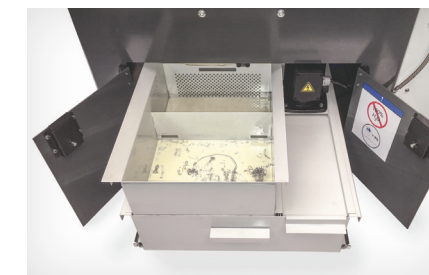

CHIP & COOLANT MANAGEMENT

Chip and coolant management is critical for any machine tool. As machinists ourselves, we know that if you can't keep chips out of the cutting area and remove them from the machine efficiently, you aren't using the machine to its full potential.



Haas Automation, Inc.
CM-1 Compact Mill

Specifications subject to change without notice. Machines shown with optional equipment. Product appearance may differ. Not responsible for typographical errors.

www.HaasCNC.com

IT'S EASIER – WITH PICTURES, VIDEOS & GRAPHICS.

THE HAAS CONTROL– Designed, built, and programmed by Haas.

The Haas control – hardware and software – is designed and built in-house, and optimized specifically for Haas machine tools. If there is a problem – Haas Automation takes full responsibility for the entire machine. The Haas control is easy to learn and use, and it is the same across the entire product line. Haas machines are also used extensively in educational institutions around the world, so graduating students are already familiar with the Haas control, which makes finding new operators and programmers easier, and simplifies training.

STANDARD CONTROL FEATURES:

- Dedicated Keypad
- One-Button Features
- Multi-Function Jog Handle
- 15" Color LCD Screen
- Ethernet Interface
- Control Touchscreen
- Advanced Tool Management
- HaasDrop Wireless File Transfer
- USB Port
- 1 GB Memory
- Power-Failure Detection Module
- M130 Media Player
- HaasConnect Mobile Monitoring
- WiFi Connectivity



VISUAL PROGRAMMING SYSTEM

The Haas Visual Programming System uses graphical templates and a form-like interface to help you quickly create G-code programs for not only basic part features, but also more complex operations, like Y-axis milling/drilling, probing, and more. Simply define the feature in the template, and VPS then outputs working G-code at the touch of a button. VPS also includes a custom template generator, so you can create templates for your own part features or frequently used programs.



M130 MEDIA DISPLAY

The Haas M130 Media Display M-Code is a powerful tool for communicating with machine operators and programmers directly from the Haas control. Use M130 to call up setup instructions, tool lists, part images, manufacturing information, and more. When the program reaches an M130, the specified media (image, video, or PDF) will be displayed in the upper right corner of the control screen.



- Explain difficult-to-understand secondary operations, using pictures and videos
- Avoid miscommunications with your shop peers
- Describe step-by-step part inspection processes
- Share important setup information with shop personnel



ALARM VIDEOS

When your machine alarms out, the first thing you want to know is: Why? The Haas control not only includes fully descriptive alarm text explaining the problem, but for many common alarms, it also includes short videos explaining the alarm, and providing valuable troubleshooting tips to resolve the issue.

MAKE THE CONNECTION WITH HAASCONNECT

Get your machine status notifications anywhere, on any device! The Haas Control has the ability to send you, and others you designate, email notifications about the operating status of your Haas machine. Set up is fast and easy through the MyHaas Portal and HaasCNC.com.



Haas Automation, Inc.
2800 Sturgis Rd., Oxnard, CA, USA, +1-805-278-1800

Haas Automation Europe
Mercuriusstraat 28, B-1930 Zaventem, Belgium, +32 2 522 99 05

Specifications subject to change without notice. Not responsible for typographical errors. Machines shown with optional equipment. Actual product appearance may differ. Pricing subject to change without notice.

