

*All Height Dimensions Based on Suggested Leg Height

Air & Power

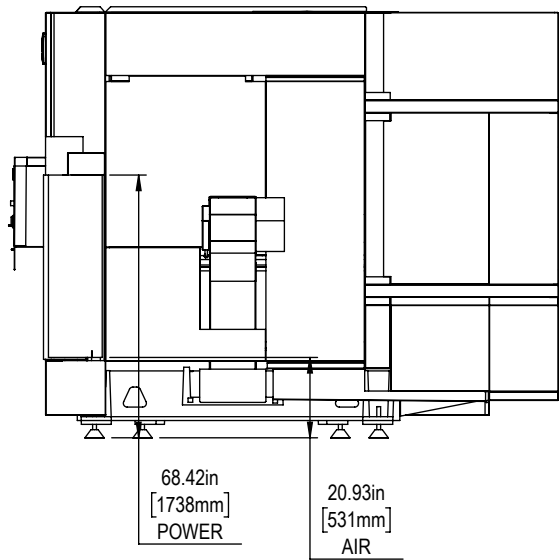

Side Mounted Tool Changer Facing Window

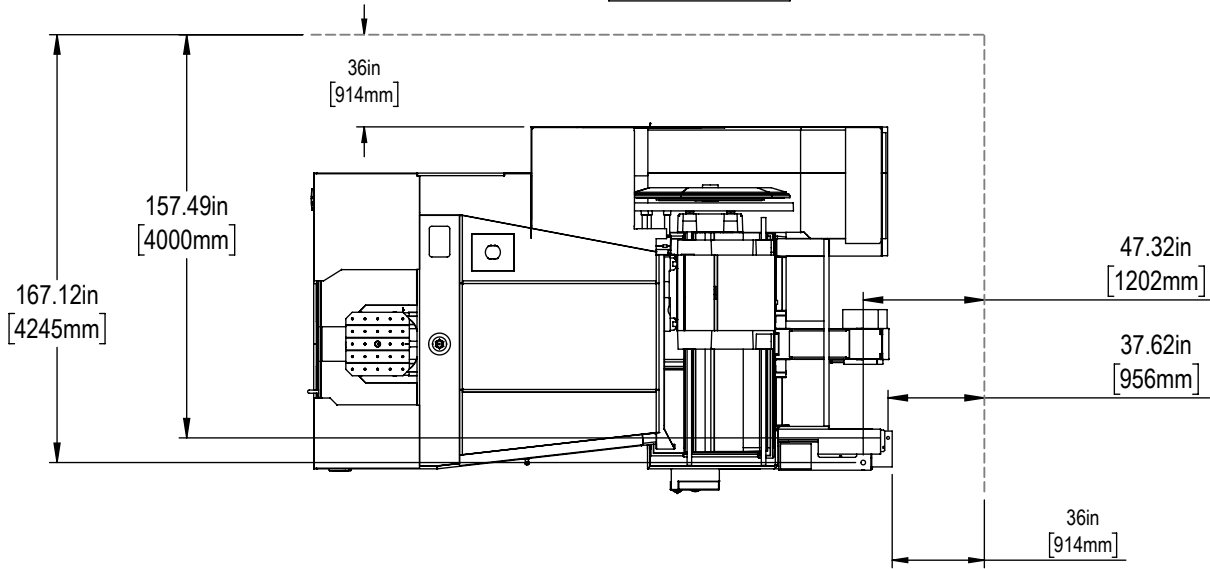
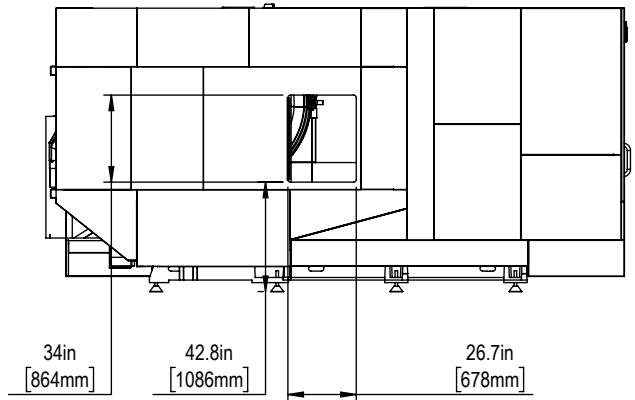

Anchor Pattern

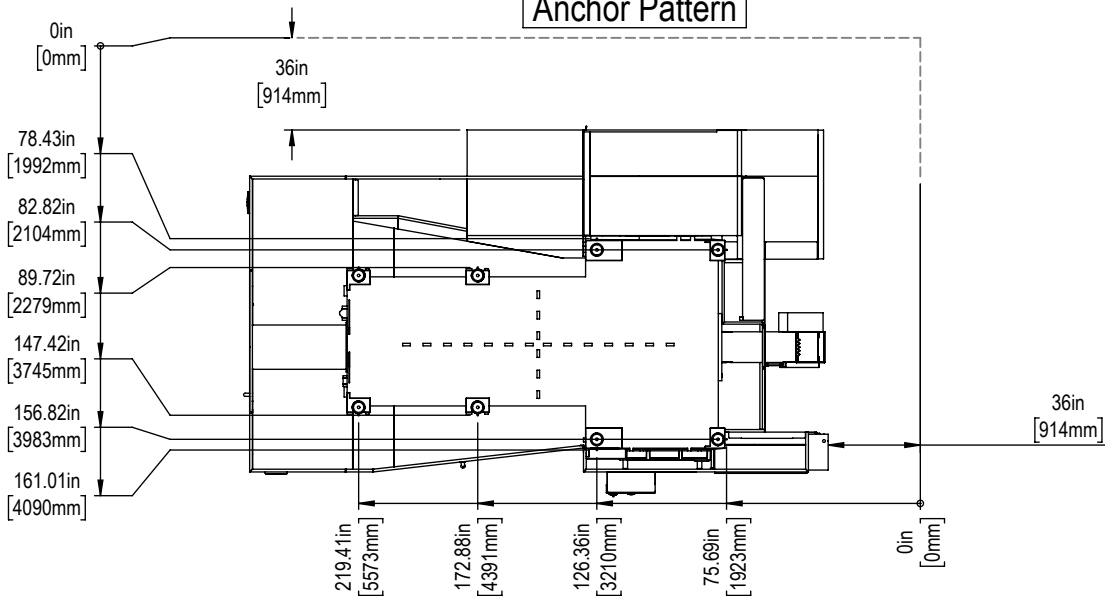

Height Breakdown

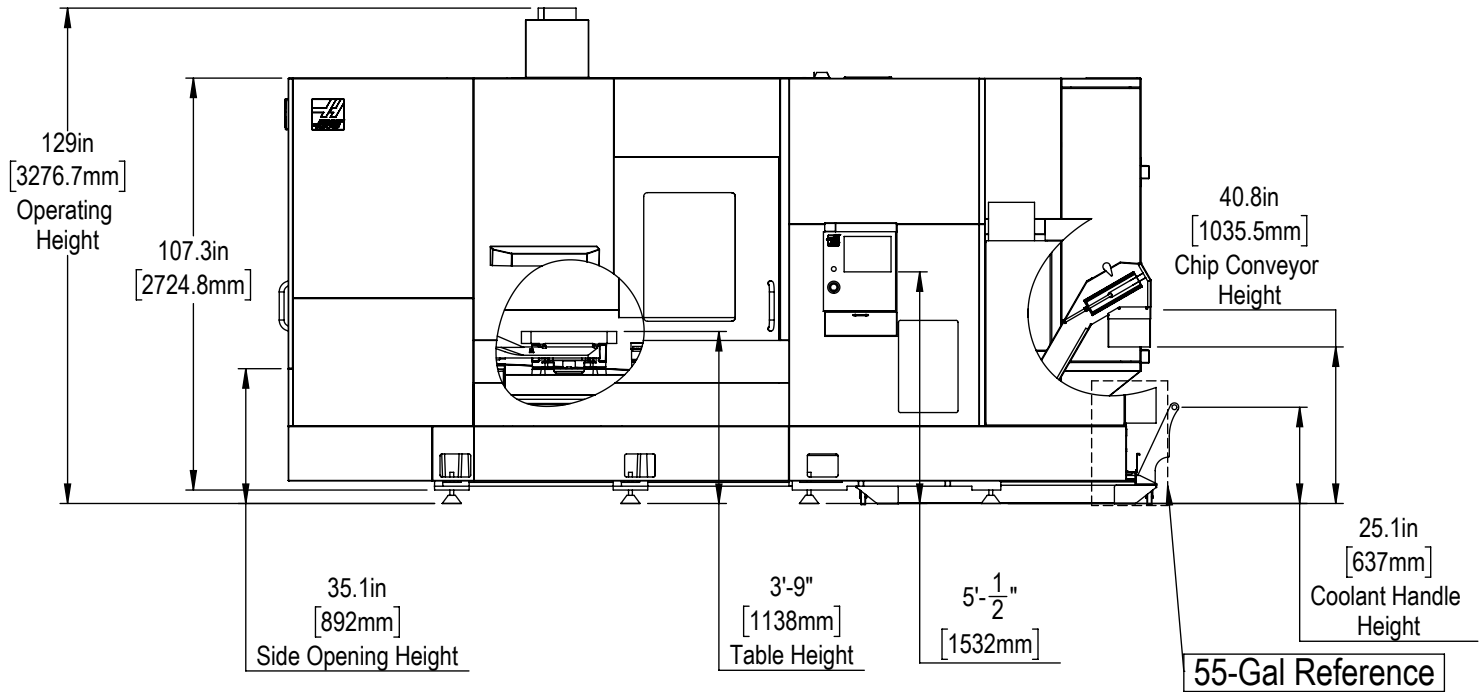

Width Breakdown

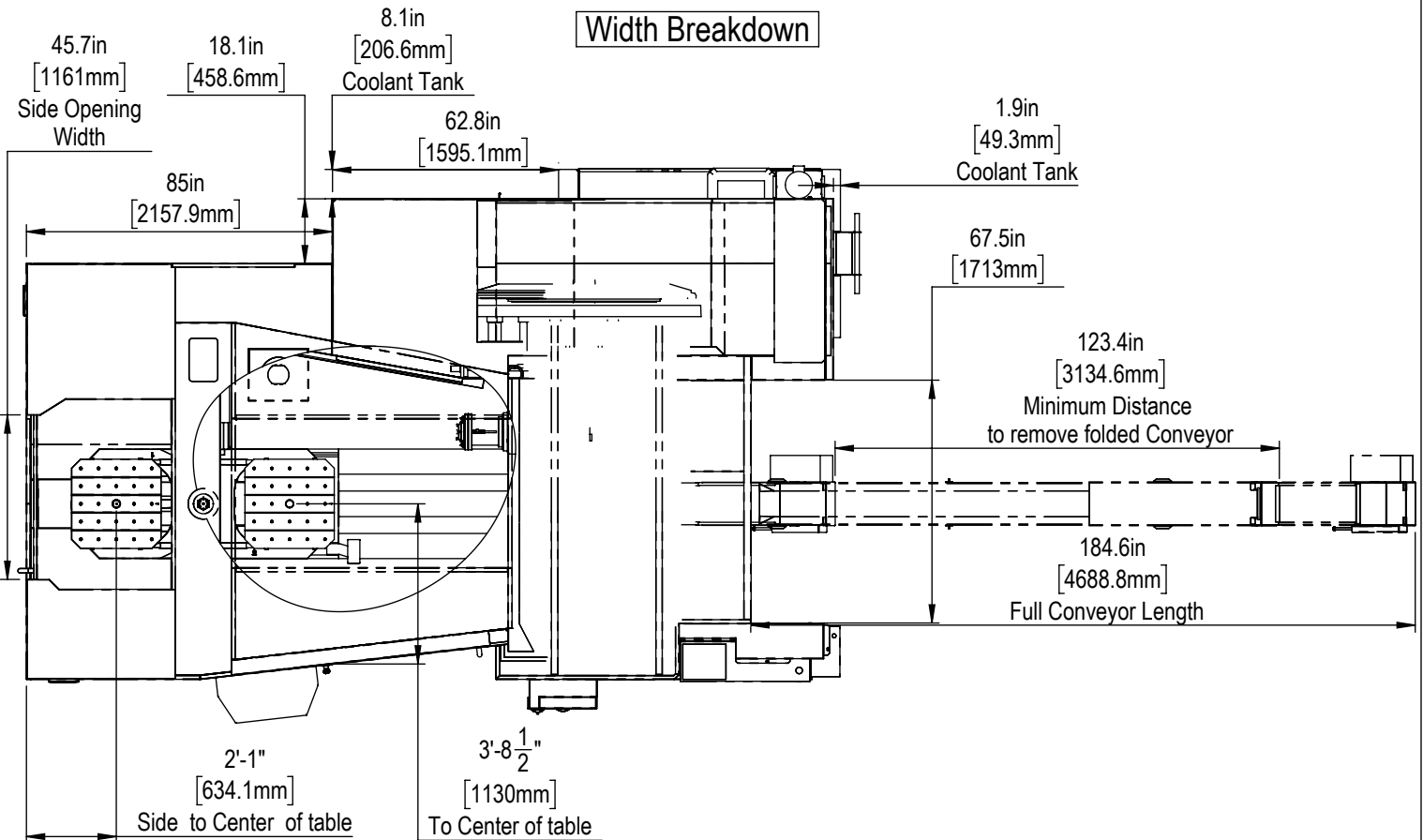

Maintain 3 feet [915mm] clearance to the nearest obstruction around all sides of machine perimeter for maintenance access



MAX TRAVELS

X	40in [1016mm] X-AXIS TRAVEL
Y	37in [939.8mm] Y-AXIS TRAVEL
Z	40in [1016mm] Z-AXIS TRAVEL
B	360° 40in [1016mm] X-AXIS TRAVEL

X&Y Axis Clearance

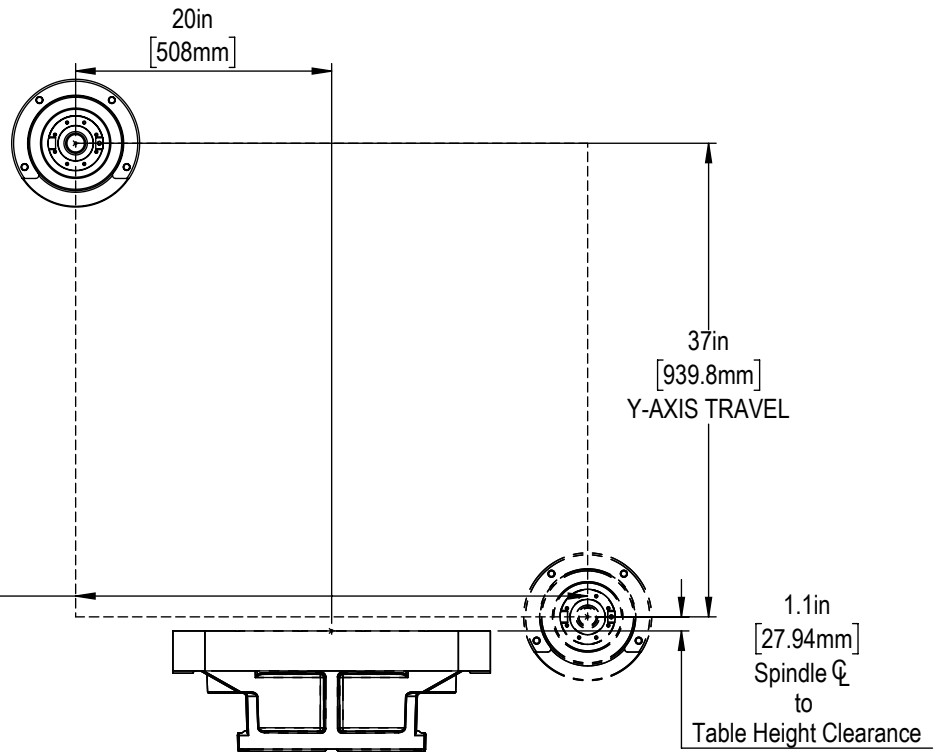

40in
[1016mm]
Z-AXIS
TRAVEL

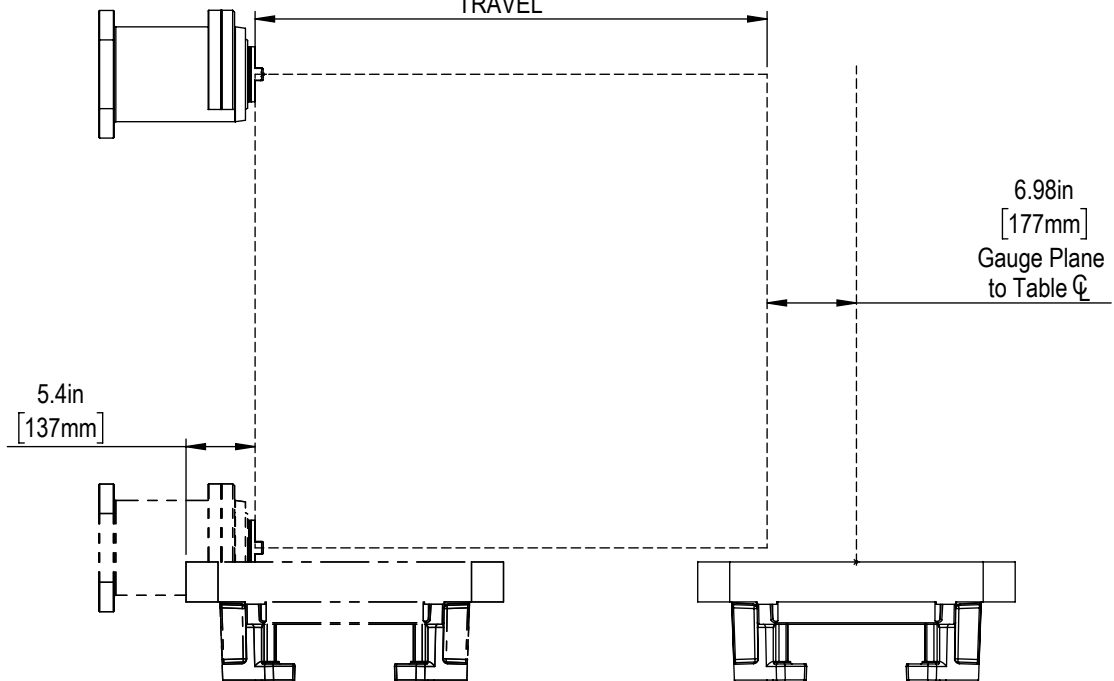



SAE/ Inch Pallet

ISO/Metric Pallet

24 x \varnothing 0.53in [13mm] ∇ 1.75in [44mm]
5/8-11 UNC ∇ 1.25in [32mm]

24 x \varnothing 0.55in [14mm] ∇ 1.75in [44mm]
M16x2.0 - 6H ∇ 1.25in [32mm]

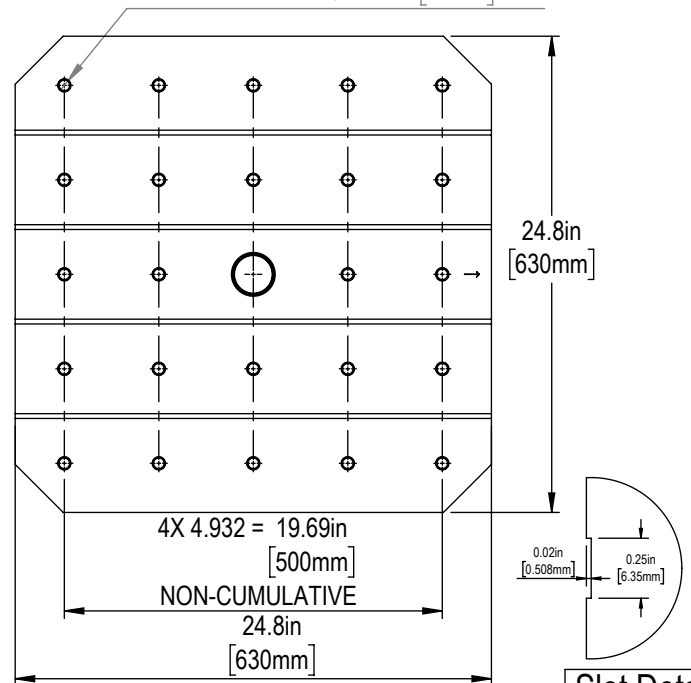
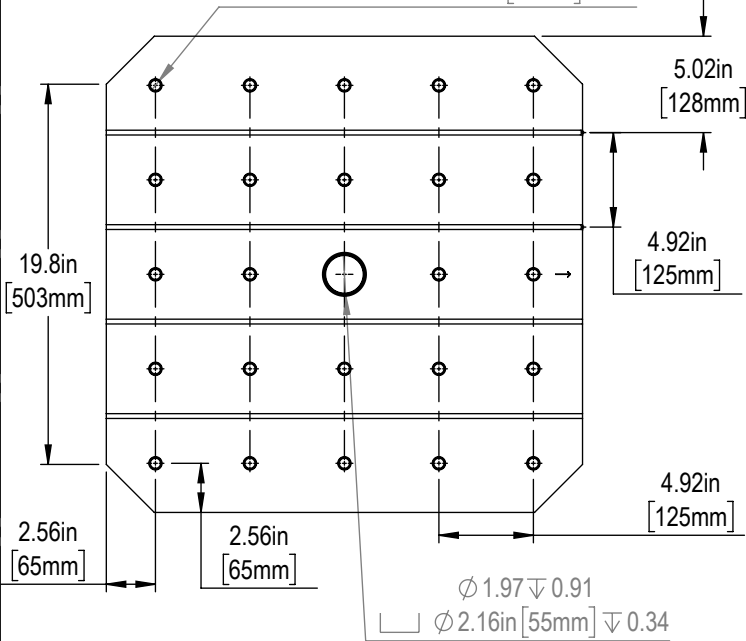

Both Pallets Identical Besides Hole Dimensions

Slot Detail

Max Part Load:
1500lb
680kg

