

Total Weight of the Dual Pneumatic Gripper:  
About 7 lbs [3.2 kg]

Theoretical Maximum Part Weight per Gripper:  
About 7.5 lbs [3.4 kg]\*

Theoretical Maximum Part Weight for Both Grippers:  
About 15.02 lbs [6.8 kg]\*

Minimum Part Diameter:  $\varnothing 0.9$  in [22.8 mm]\*  
Maximum Part Diameter:  $\varnothing 5.02$  in [127.6 mm]\*

Stroke:  $\varnothing 1.57$  in [40.0 mm]

Holding Force:

- 22.48 lbs [100.0 N] (Closed)

Pressure Range:

- 14.5 - 87.0 PSI [0.1 - 0.6 MPa]

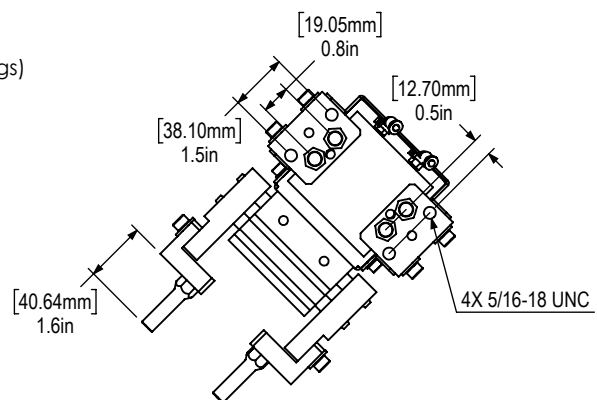
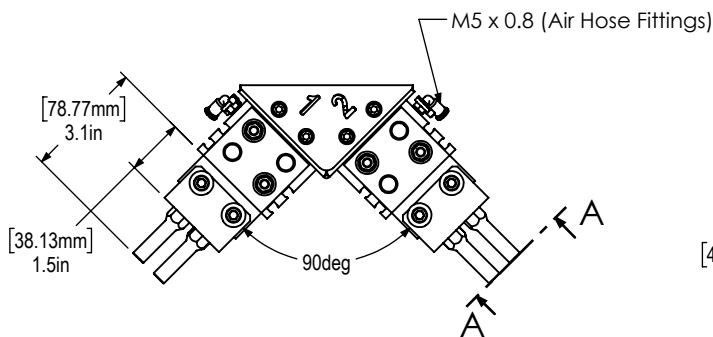
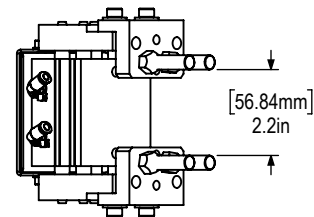
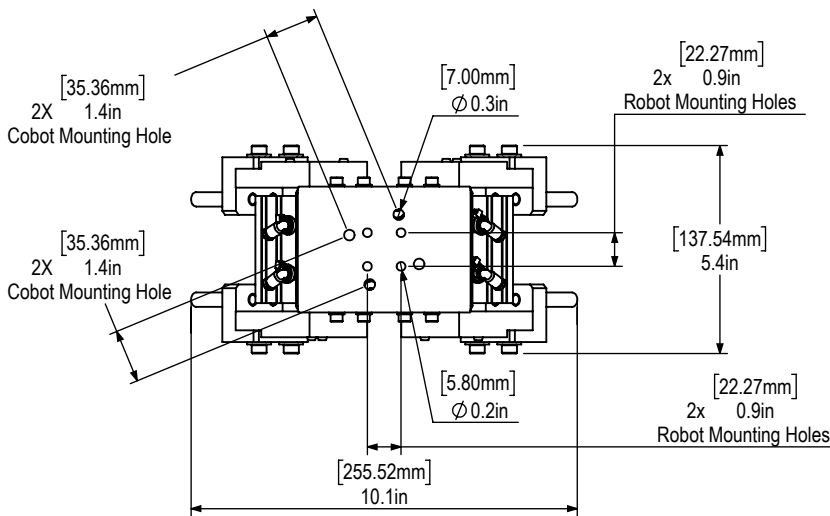
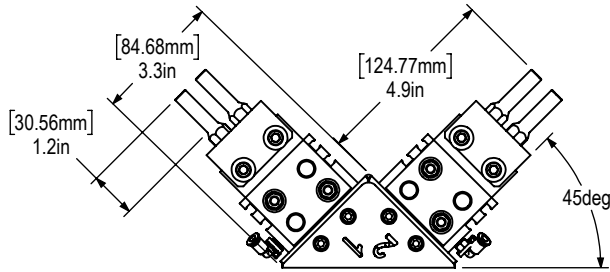

SECTION A-A

\*Weight varies for each set up. Test weight of part before usage

\*See Page 3 for more information on max part size

## ROUND STOCK

Puck Grippers (Inch) (Configuration 1)			
Position	Min Ø (Inch)	Max Ø (Inch)	
1	2.34	3.88	
2	3.54	5.02	

Puck Grippers (Inch) (Configuration 1)			
Position	Min Ø (mm)	Max Ø (mm)	
1	59.50	98.50	
2	89.80	127.60	

Puck Grippers (mm) (Configuration 2)			
Position	Min Ø (Inch)	Max Ø (Inch)	
1	0.90	2.33	
2	2.15	3.53	

Puck Grippers (mm) (Configuration 2)			
Position	Min Ø (mm)	Max Ø (mm)	
1	22.80	59.28	
2	54.55	89.61	

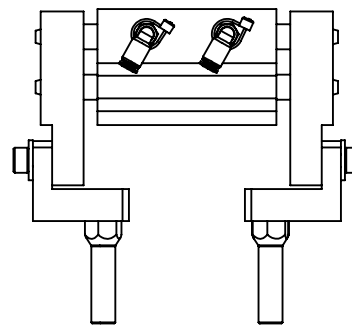
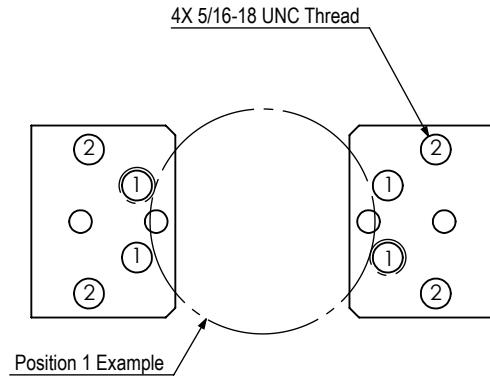

Configuration 1

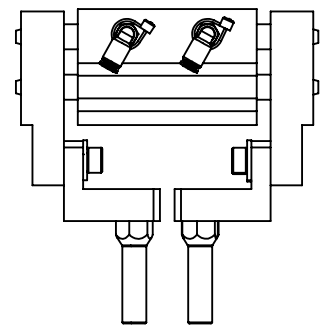

Configuration 2

## SHAFT STOCK

Gripper Finger Range (Inch)				
	Lower Opening	Lower Opening	Upper Opening	Upper Opening
Position	Min Ø (Inch)	Max Ø (Inch)	Min Ø (Inch)	Max Ø (Inch)
1	0.90	2.40	1.24	2.60
2	1.49	3.01	1.78	3.19
3	2.08	3.63	2.32	3.78
4	3.31	4.26	2.89	4.38

Gripper Finger Range (mm)				
	Lower Opening	Lower Opening	Upper Opening	Upper Opening
Position	Min Ø (mm)	Max Ø (mm)	Min Ø (mm)	Max Ø (mm)
1	22.92	61.04	31.62	66.26
2	37.58	76.70	45.37	81.09
3	52.95	92.43	59.13	96.10
4	68.55	108.21	73.42	111.36

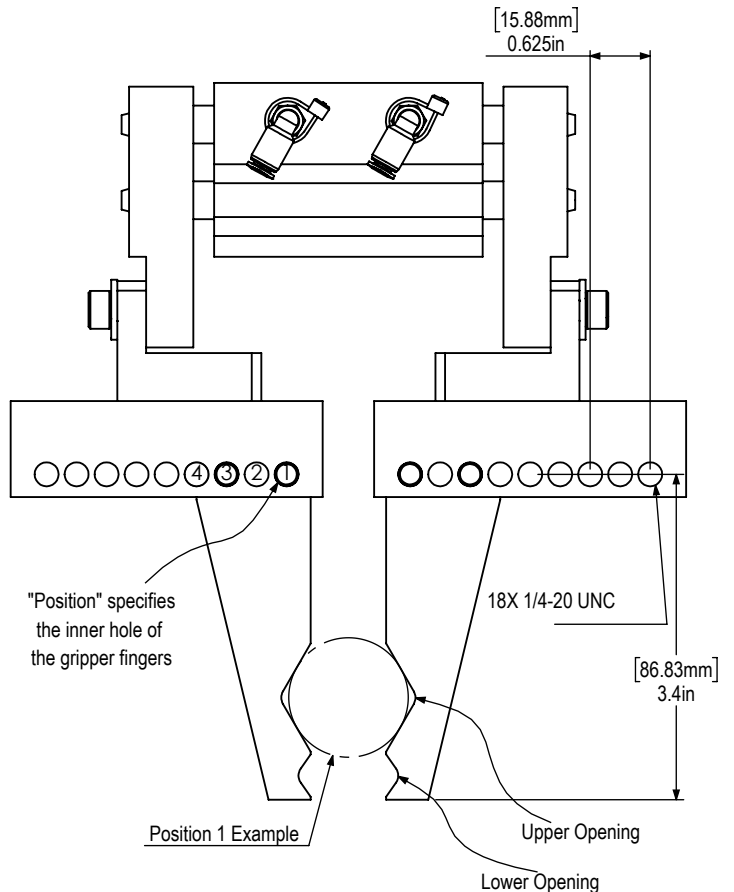

## Slug Maximum Part Size\*

"H" ≤	5.0 in [127.0 mm]
"D" ≤	6.0 in [152.3 mm]
Weight*	< 7.5 lbs [3.4 kg] per Gripper

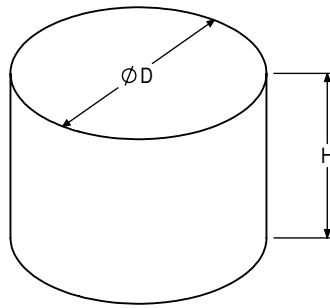

\*Part size is based on theoretical values. Test each part before usage

\*Weight cannot surpass specified value

## Shaft Stock Max Part Size\*

"L" ≤	16.0 in [406.4 mm]*
"D" ≤	4.0 in [90.9 mm]
Weight*	< 7.5 lbs [3.4 kg] per Gripper

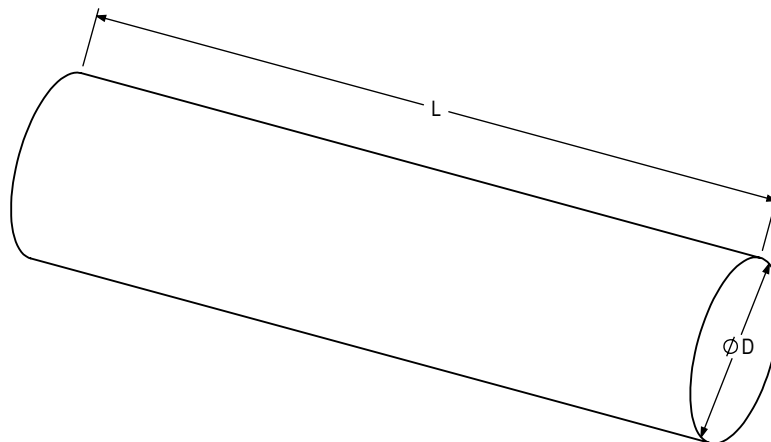

\*Part size is based on theoretical values. Test each part before usage

\*Weight cannot surpass specified value

\*Part length depends on work envelope. Verify part length fits within work envelope