

Note* 81.45" (2069 mm) with 40" Barfeeder
115" (2921 mm) with 72" Barfeeder
Dimensions in (parentheses) are based on
sheet-metal and subject to manufacturing
variation of 1/2" (12 mm)

Operating Dimensions

CL-1 Revision A
Page 1 of 2
May, 2017

*Due to continual product improvements, machine dimensions are subject to change without notice.

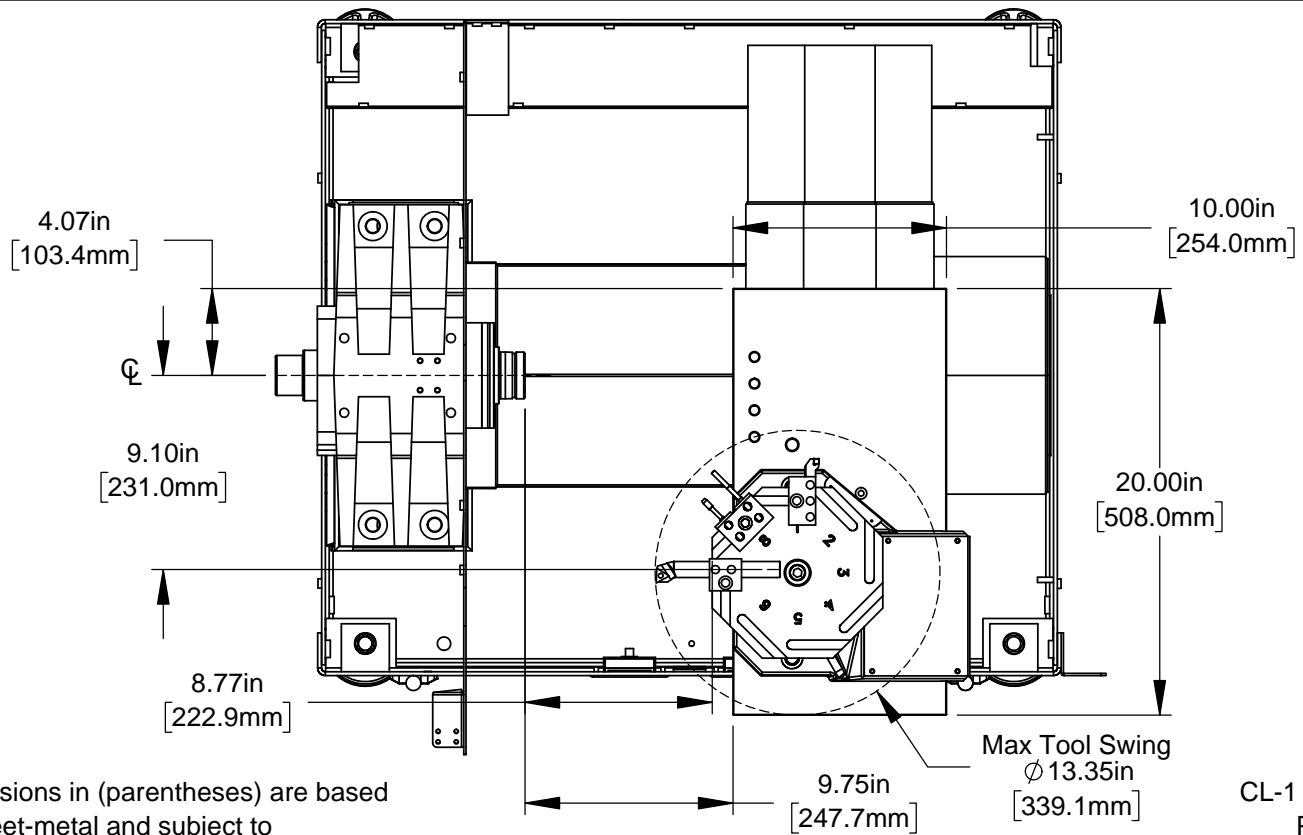
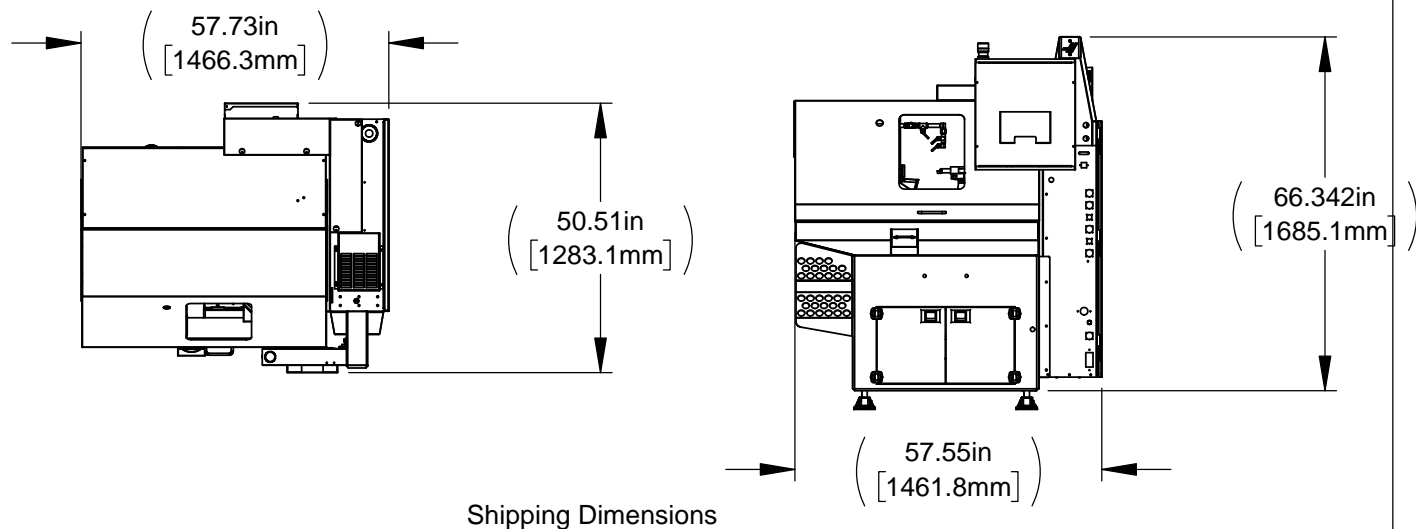
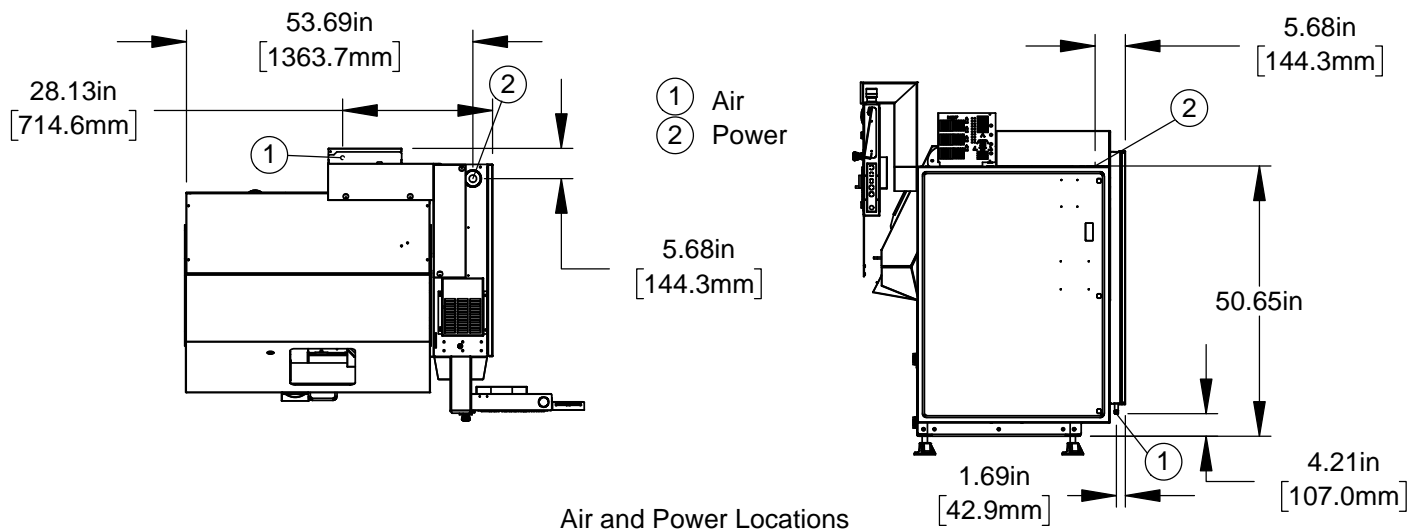

Dimensions in (parentheses) are based on sheet-metal and subject to manufacturing variation of 1/2" (12 mm)

*Due to continual product improvements, machine dimensions are subject to change without notice.