

- ① Electrical Connection
- ② Air Connection

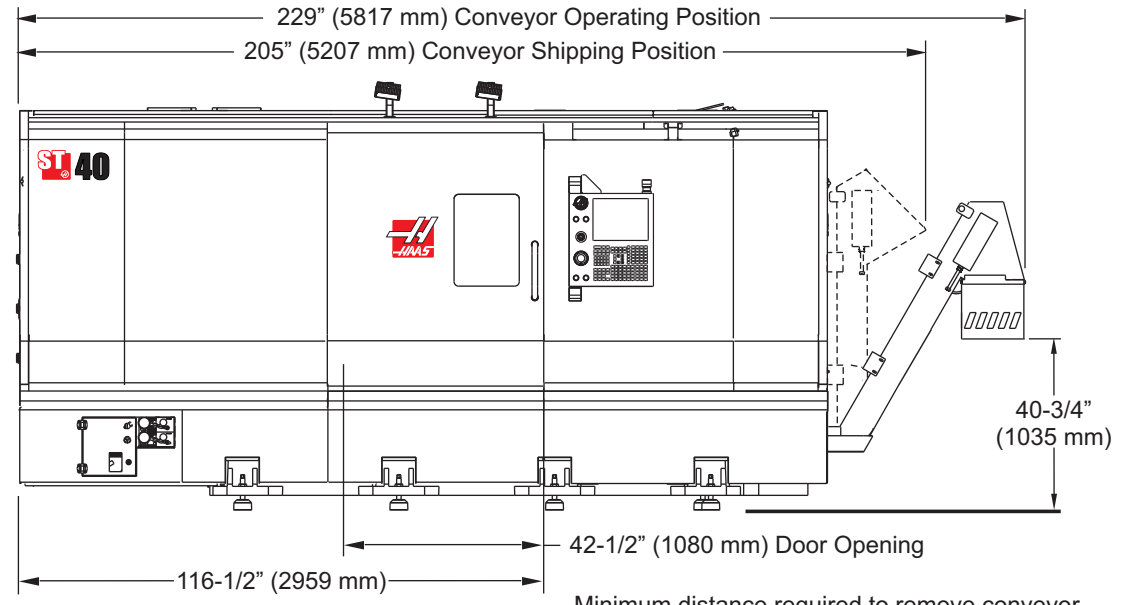

Minimum distance required to remove conveyor from lathe 156" (3962 mm).
 Minimum distance required to remove conveyor from lathe 110" (2794 mm) when conveyor is folded at 90 degrees and folded down as it is pulled out.

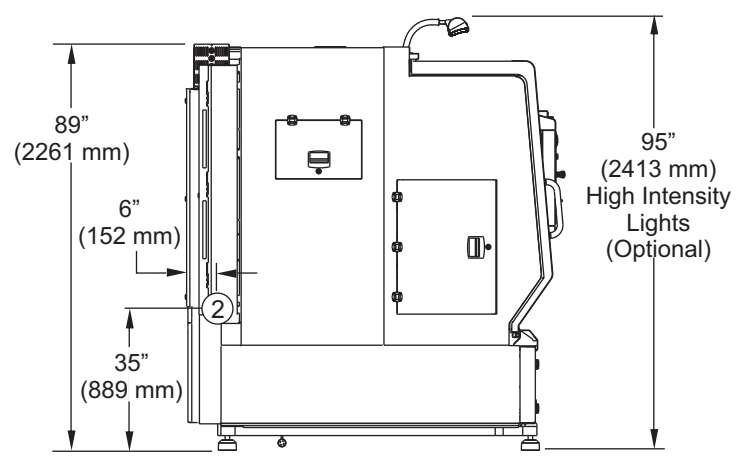
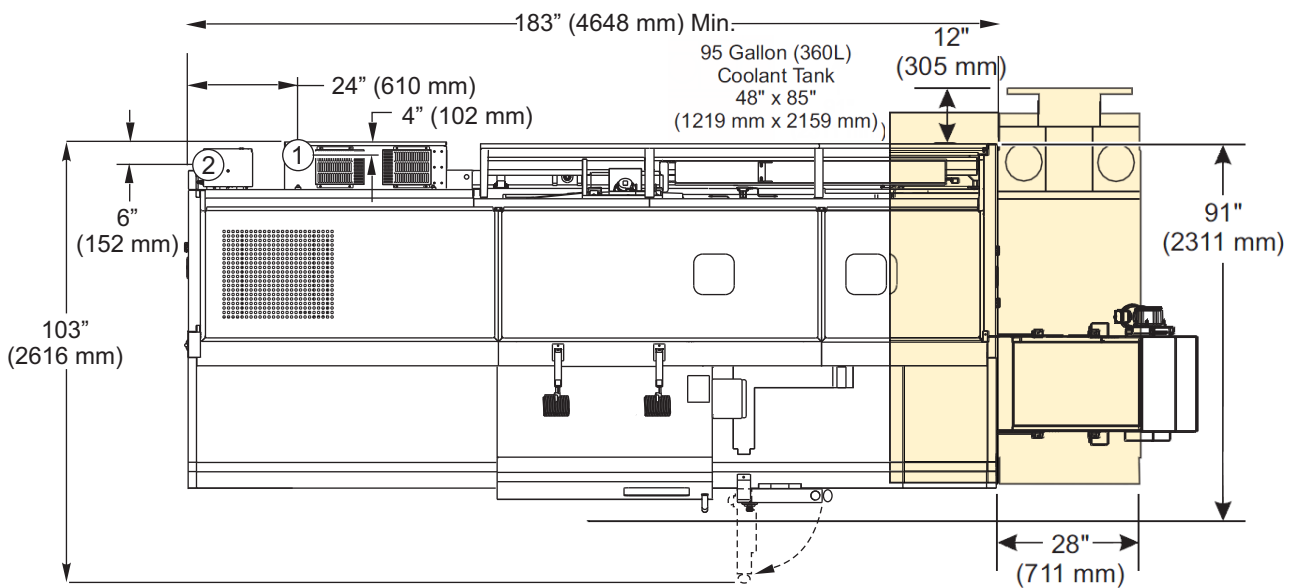
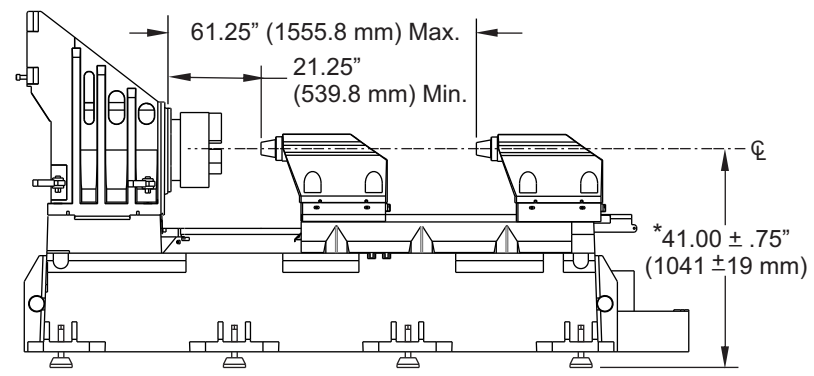
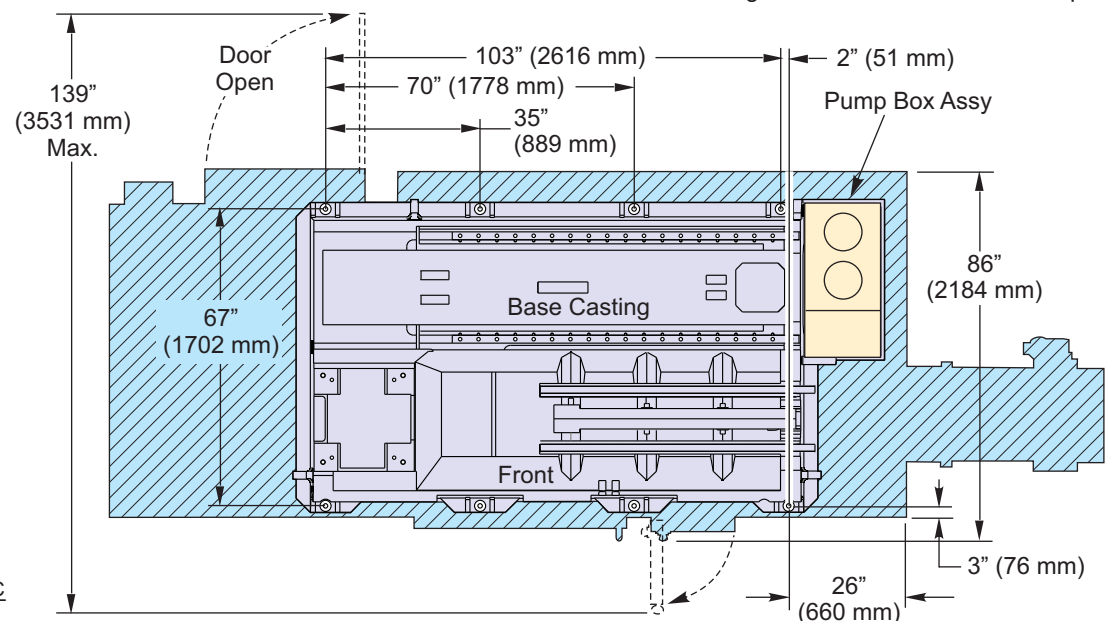
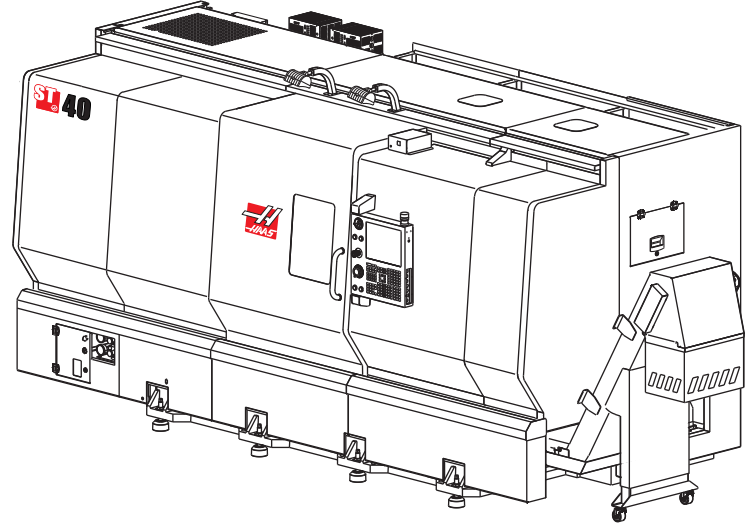

* Spindle center heights from floor, may vary due to leveling screw adjustments.

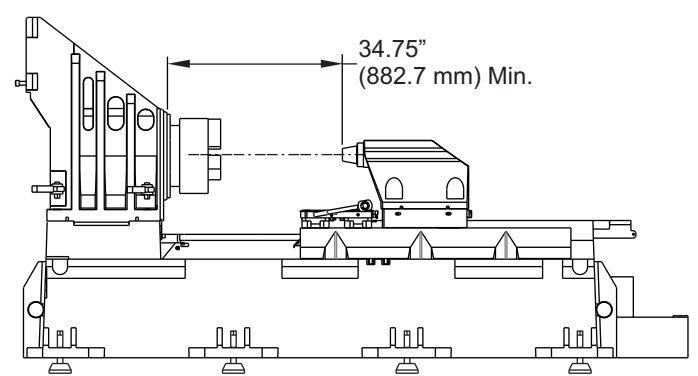
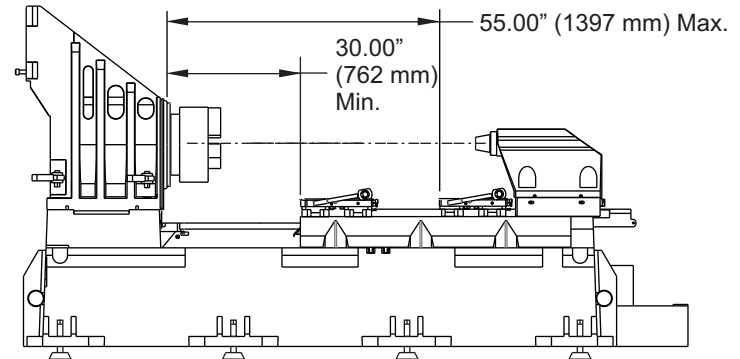

ST-40/45 Tailstock and Steady Rest Travel #5 Morse Taper

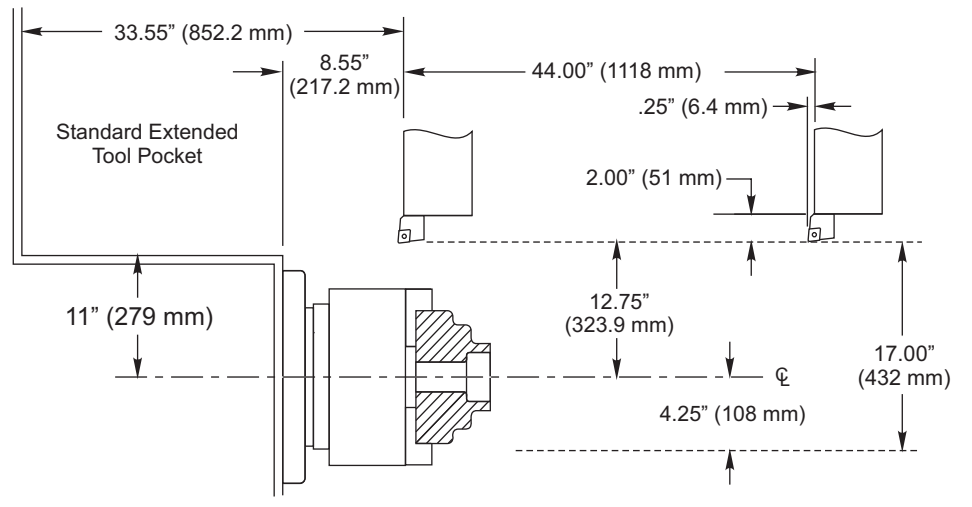

Axis Travels - ST-40/45 with Standard BOT

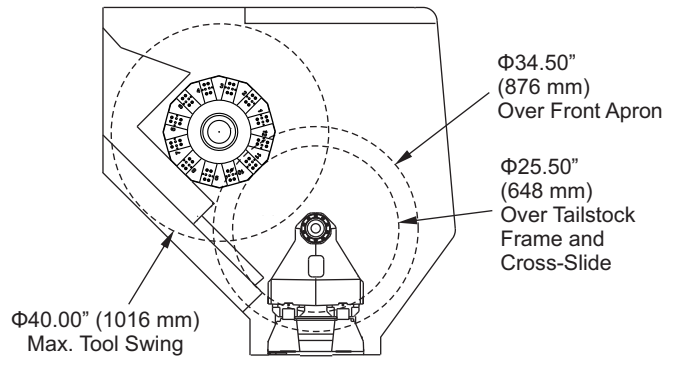

ST-40/45 Tool Swing Envelope Turret at Home Position 12-Station BOT Turret Standard

*Due to continual product improvements, machine dimensions are subject to change without notice.

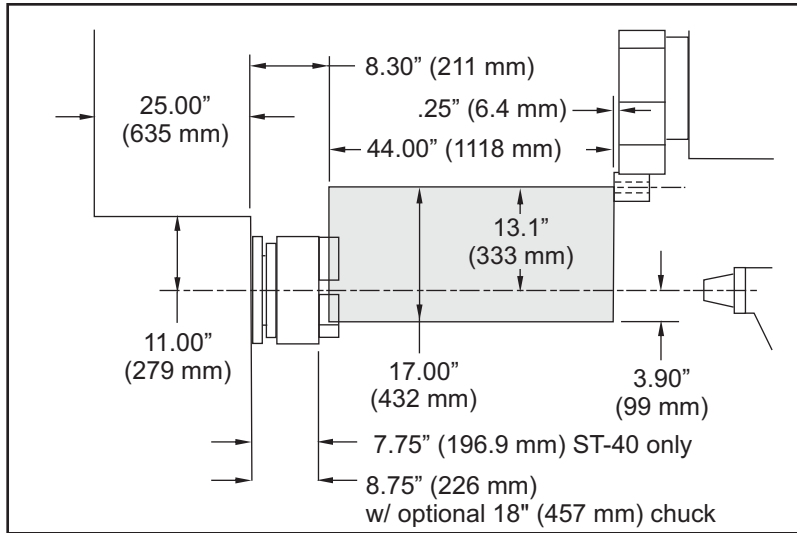
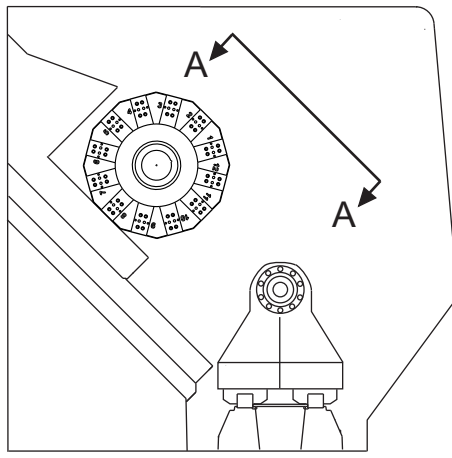

BOT/VB12 ID

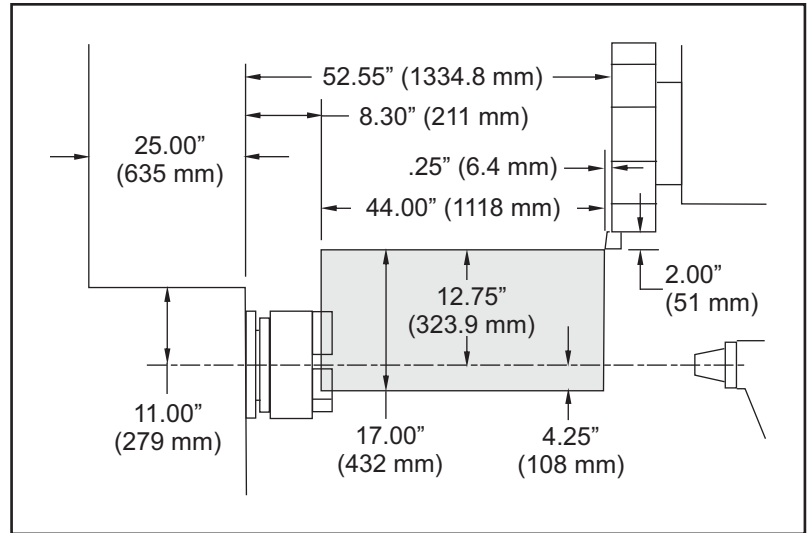

BOT/VB12 OD

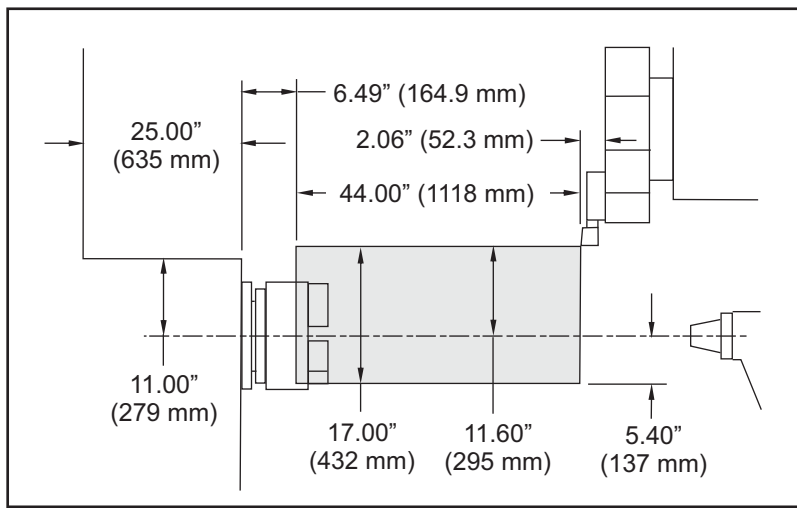

VB12 VDI OD

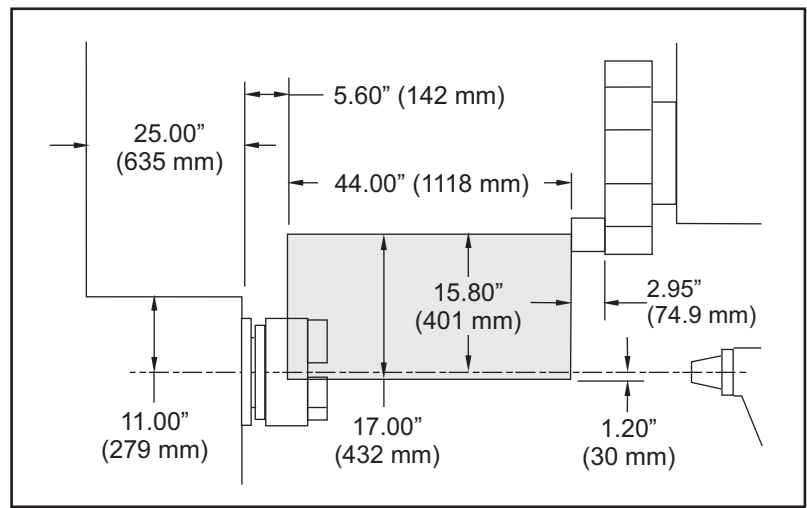

VB12 VDI ID

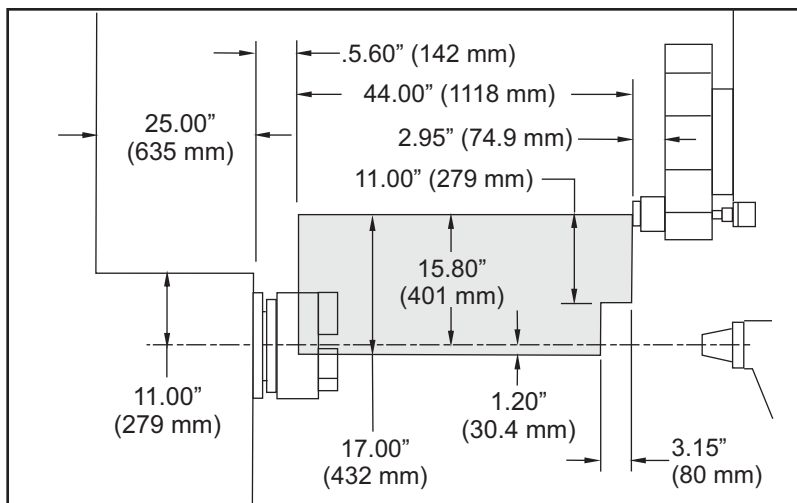

LIVE AXIAL TOOL

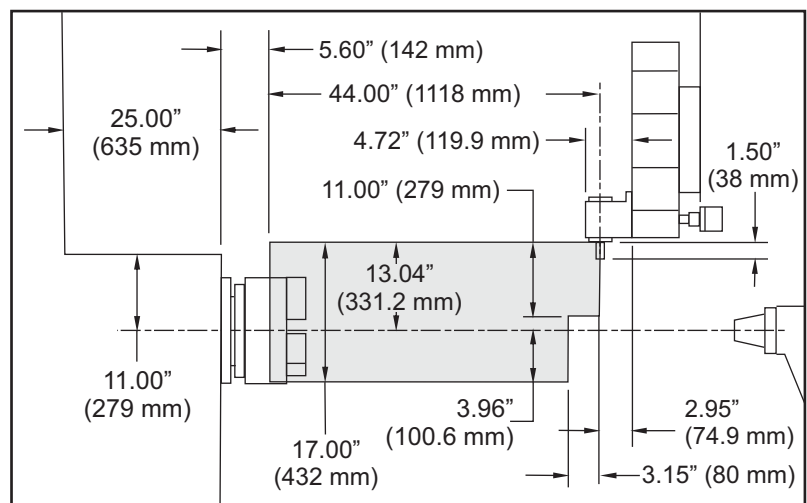

LIVE RADIAL TOOL

View A-A ST-40/45 Cut Envelope Diagrams
NOTE: No workholding standard on ST-45

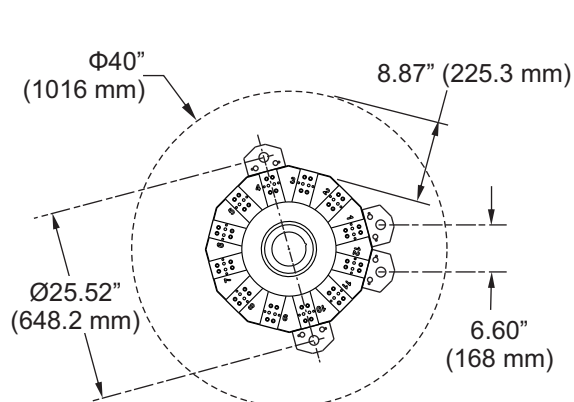

12-Station BOT Turret Standard

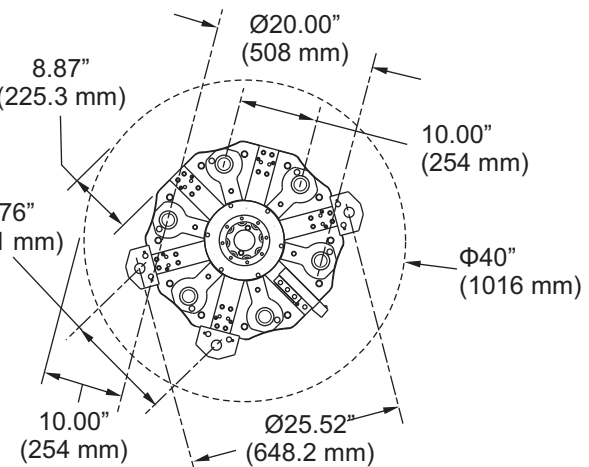

12-Station Hybrid VB12 Turret Option

ST-40/45 Tool Interference Drawings