

Measured Model configured to VF-2. If * Subtract 2.25in when mated to DT/DM

All dimensions based on stackup of sheetmetal, subject to variation of 1/2" (13mm) Due to continual product improvements, dimensions are subject to change without notice

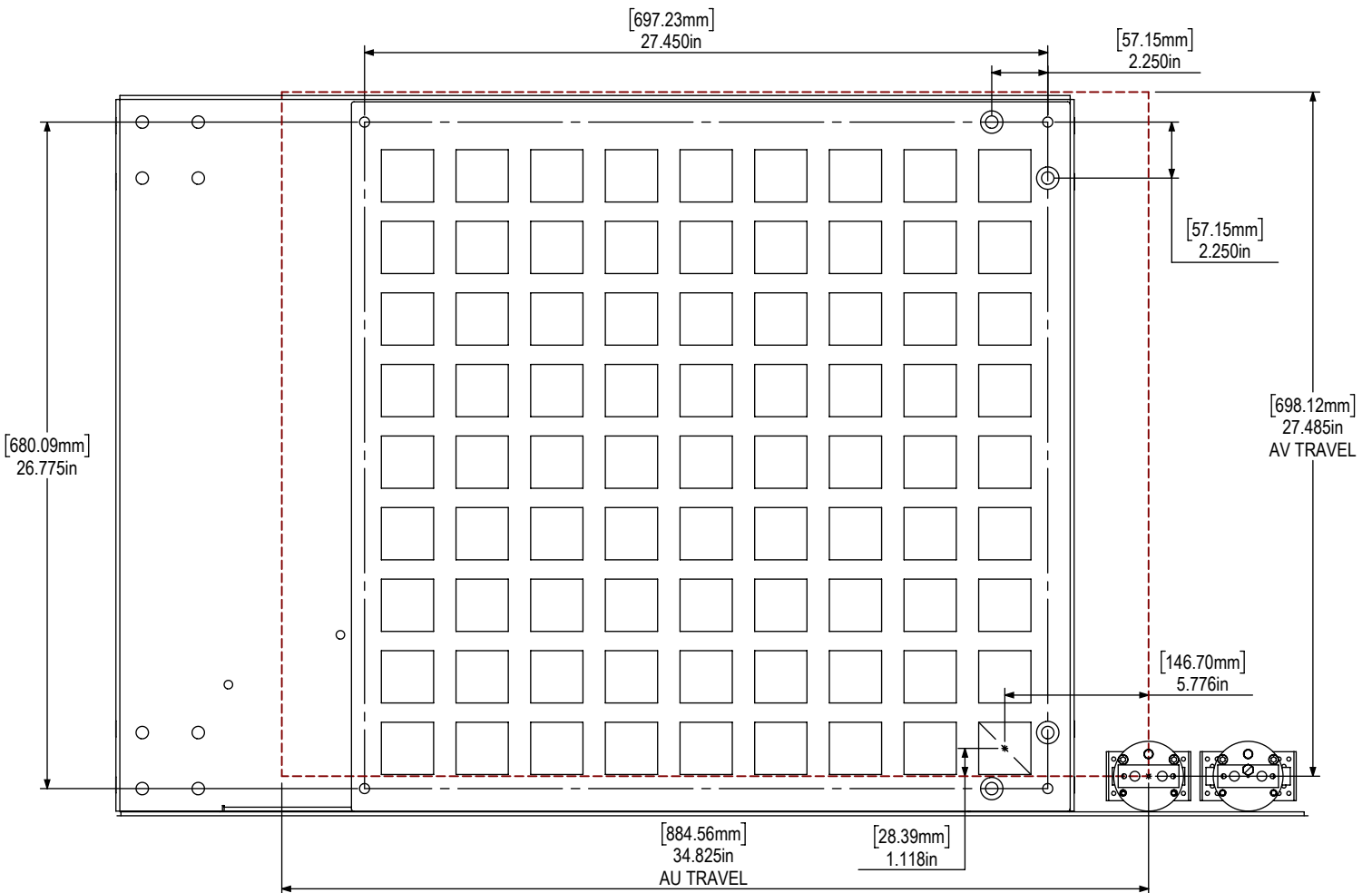

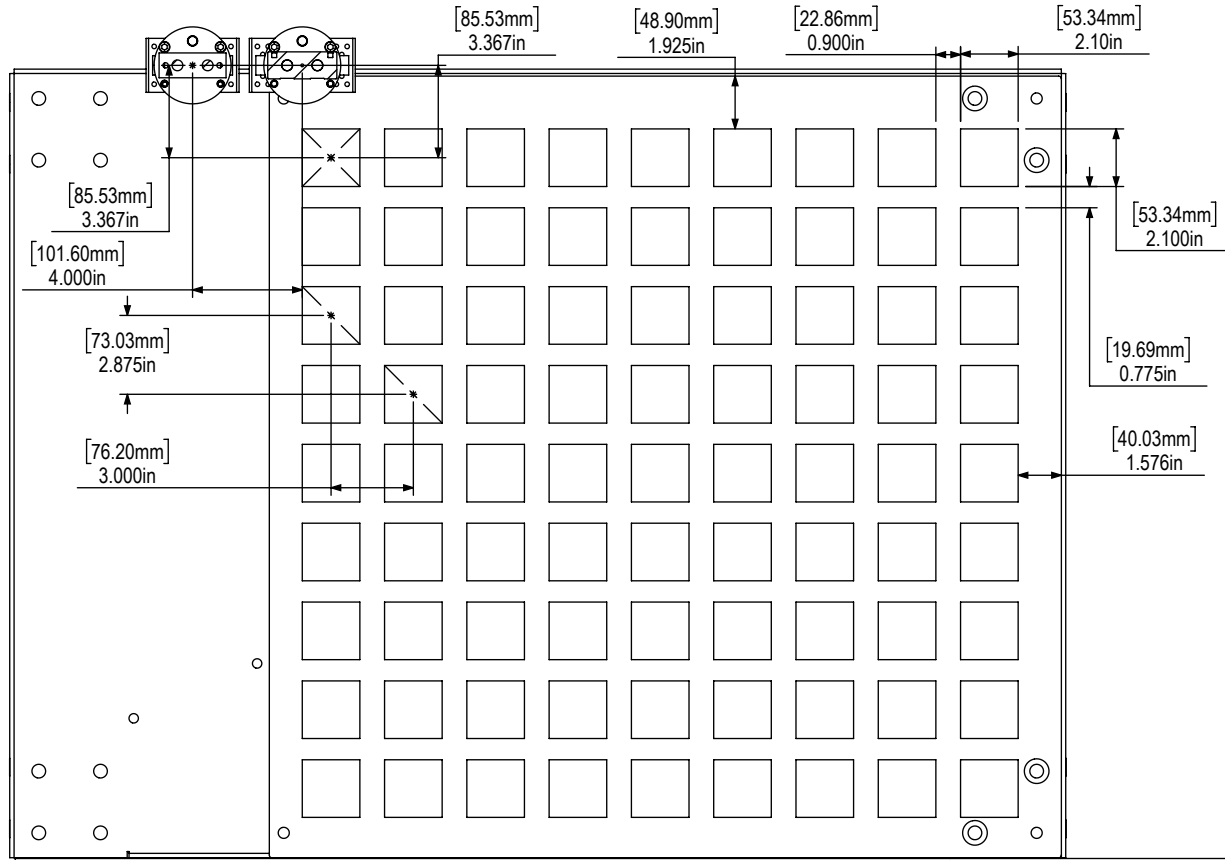
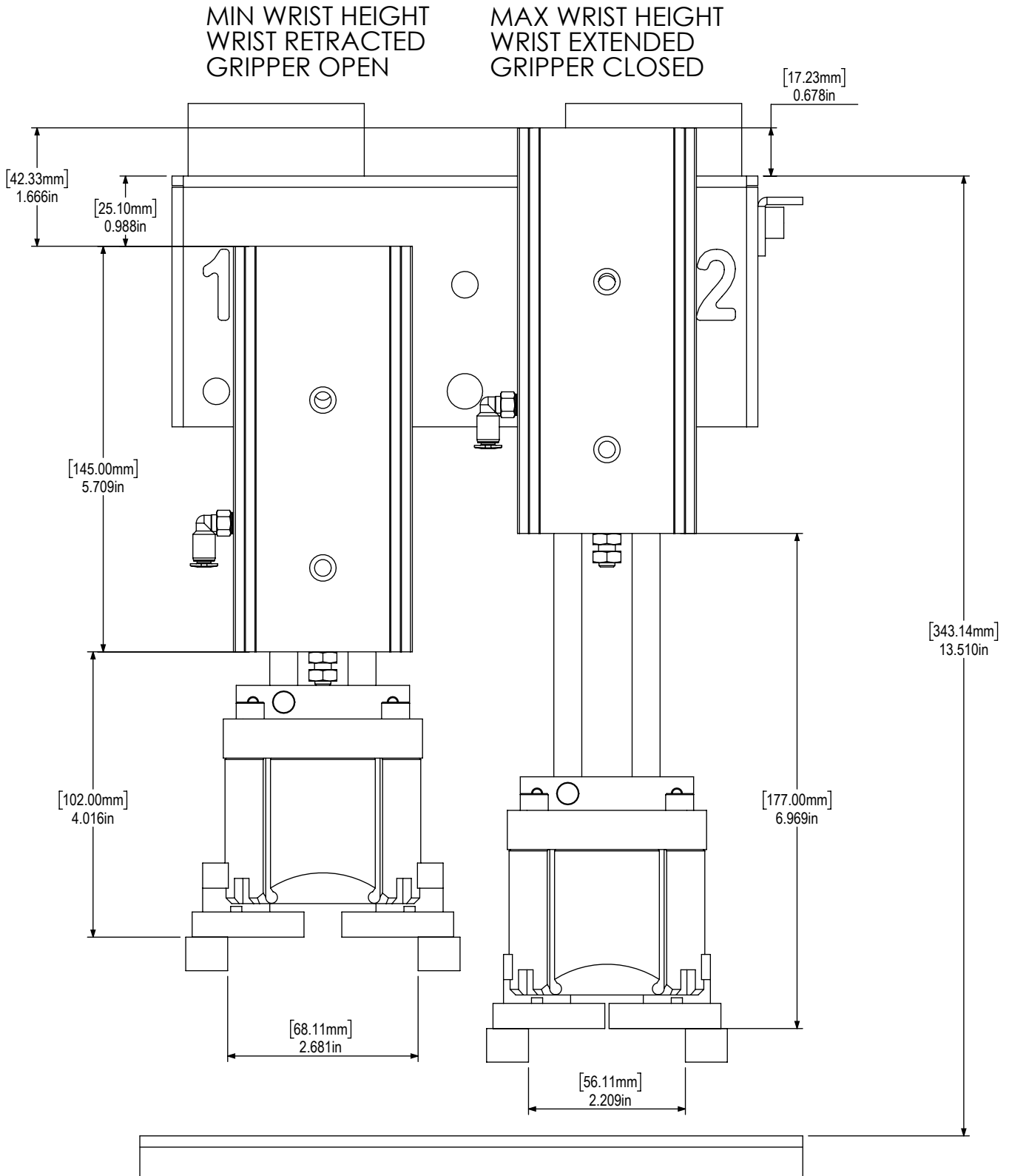

OPEN

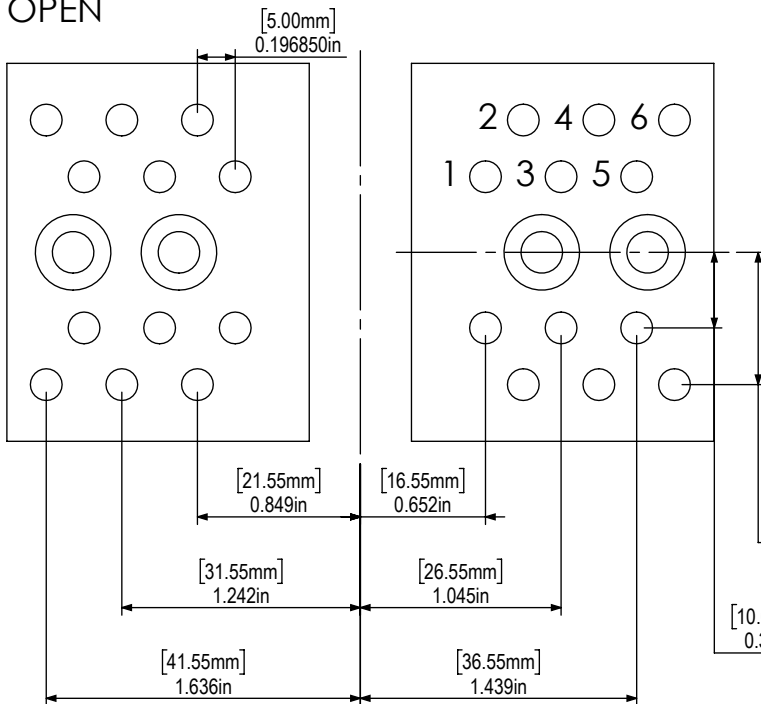

CLOSED

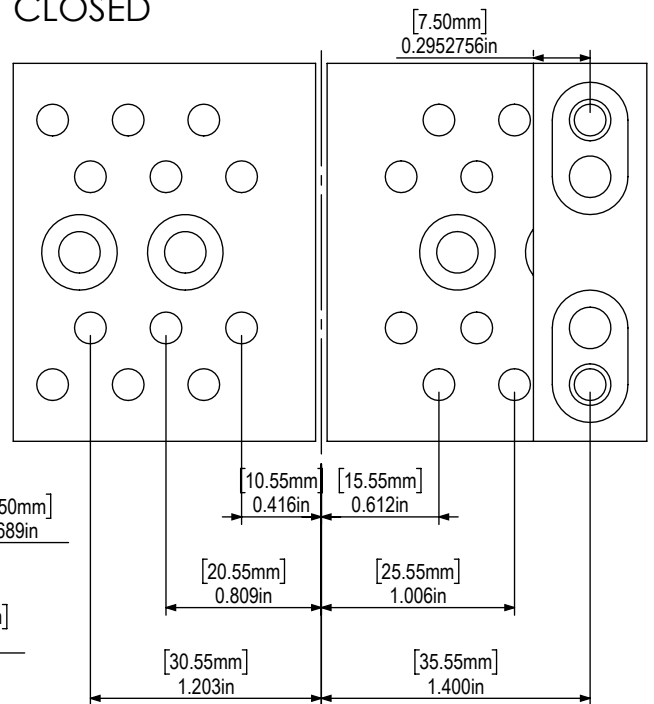

POSITION	HOLE DISTANCE FROM CENTERLINE
1	0.416in [10.55mm] - 0.652in [16.55mm]
2	0.612in [15.55mm] - 0.849in [21.55mm]
3	0.809in [20.56mm] - 1.045in [26.55mm]
4	1.006in [25.56mm] - 1.242in [31.55mm]
5	1.203in [30.57mm] - 1.439in [36.55mm]
6	1.4in [35.57mm] - 1.636in [41.55mm]
	DISTANCE BETWEEN JAWS
1	0.238in [6.06mm] - 0.711in [18.05mm]
2	0.632in [16.06mm] - 1.105in [28.05mm]
3	1.026in [26.06mm] - 1.498in [38.05mm]
4	1.42in [36.07mm] - 1.892in [48.05mm]
5	1.814in [46.08mm] - 2.286in [58.05mm]
6	2.208in [56.09mm] - 2.679in [68.05mm]