

Installed Dimensions

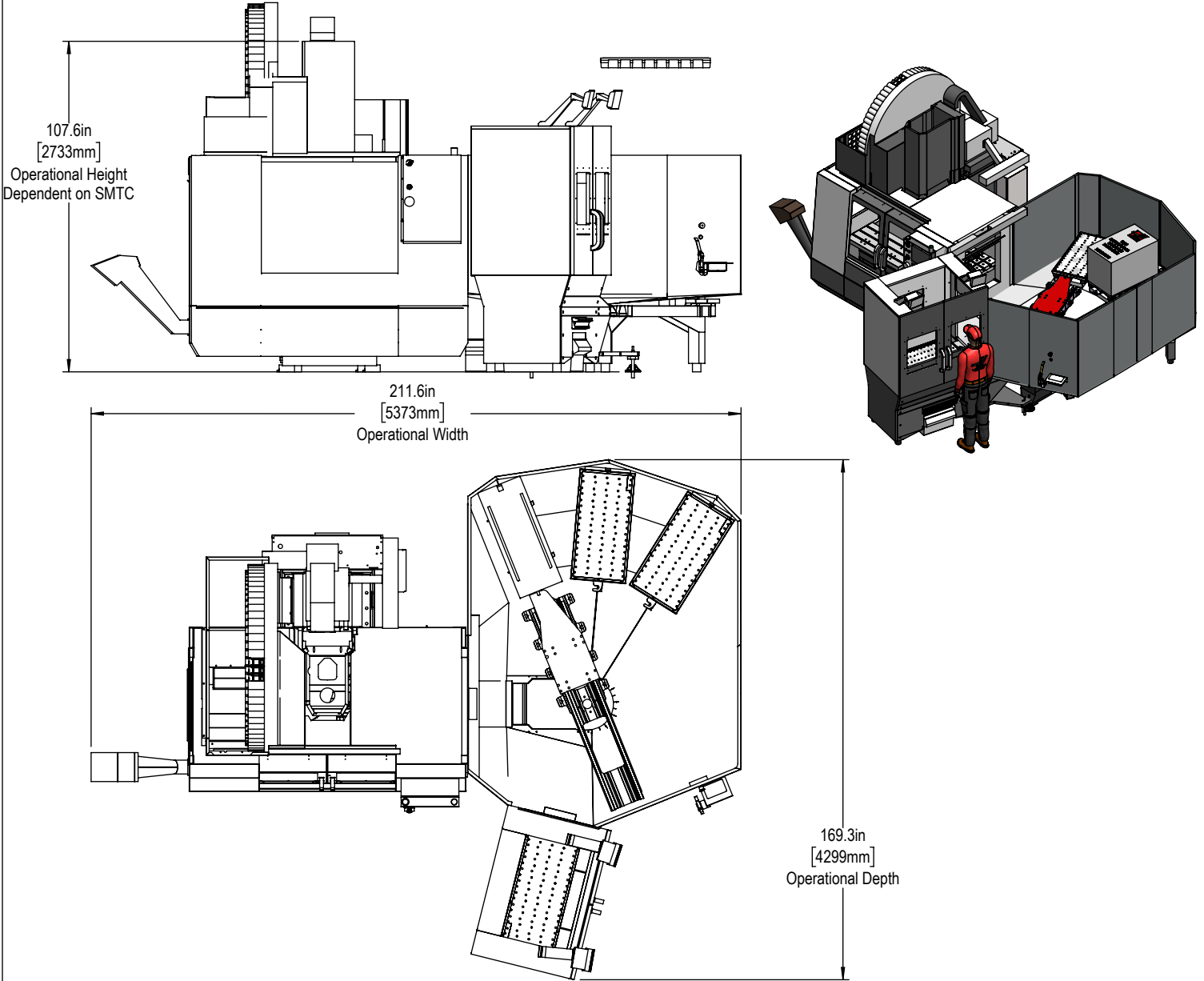

Leveling Pad Height

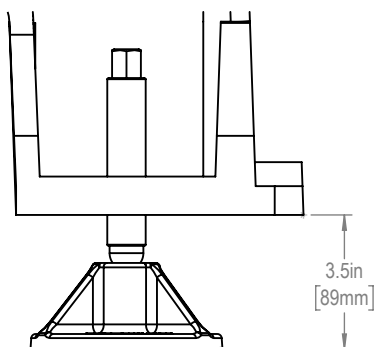

Shipping Dimensions

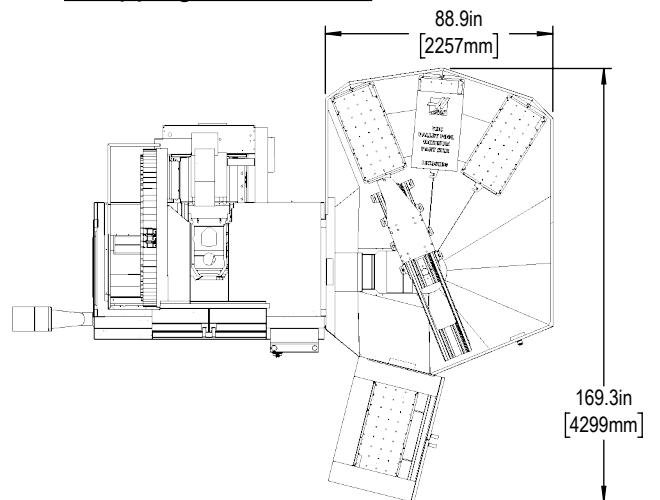

*All Height Dimensions Based on Suggested Leveling Pad Height

Air & Power

FOR AIR & POWER PLEASE REFER TO VF-2YT LAYOUT DRAWING

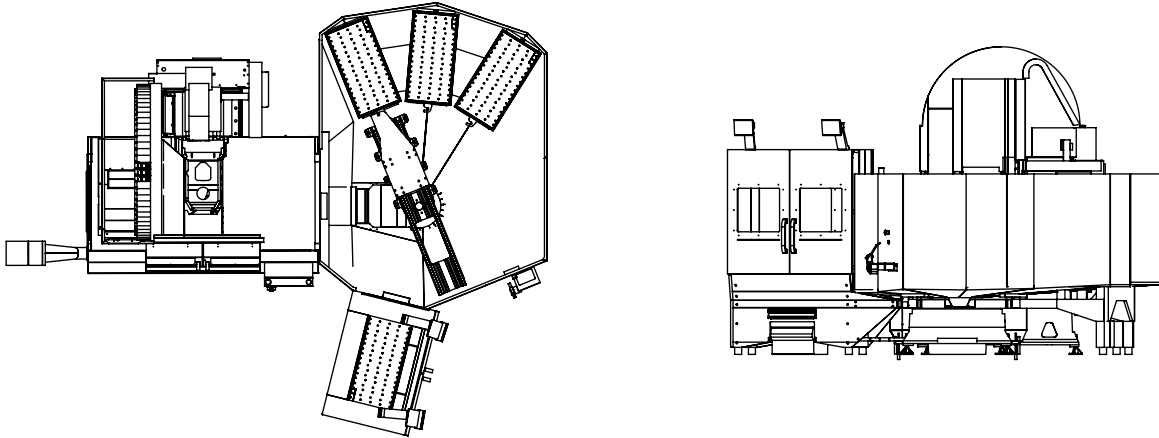

Anchor Pattern

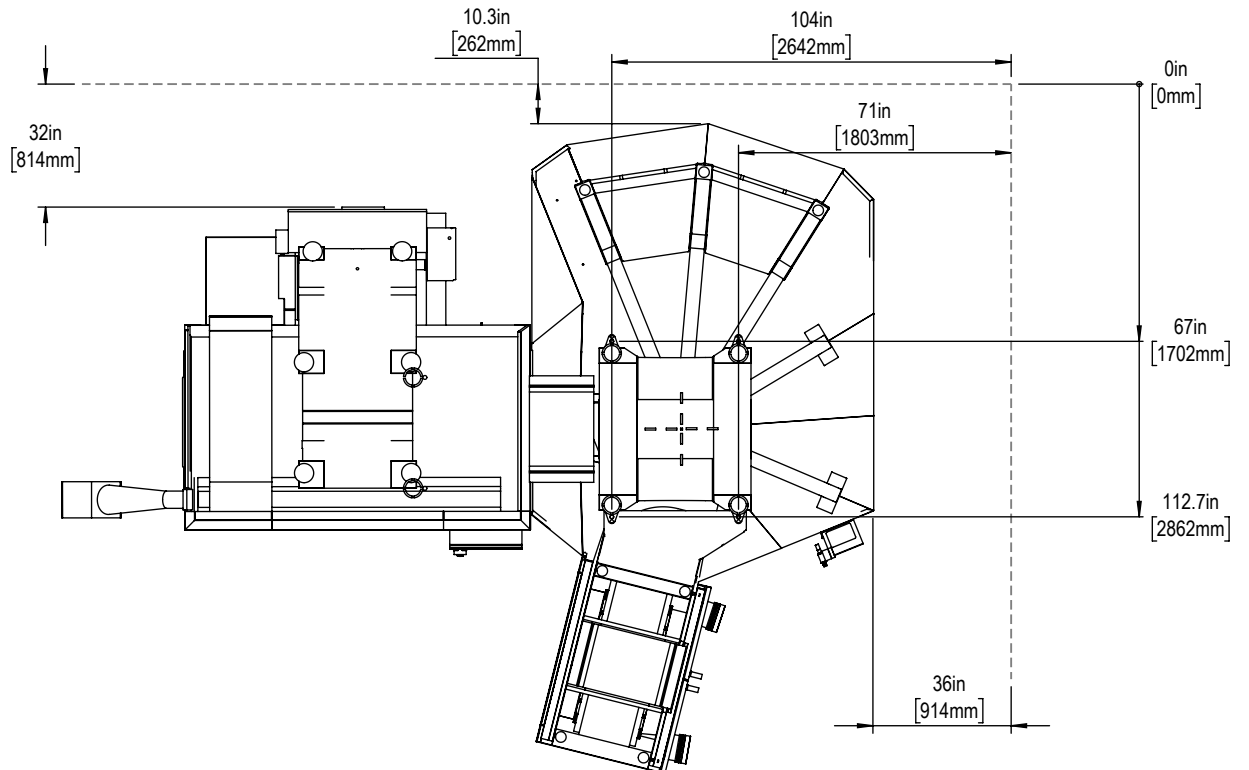

For precise locations please use template in Anchoring Kit found at Haascnc.com



Height Breakdown

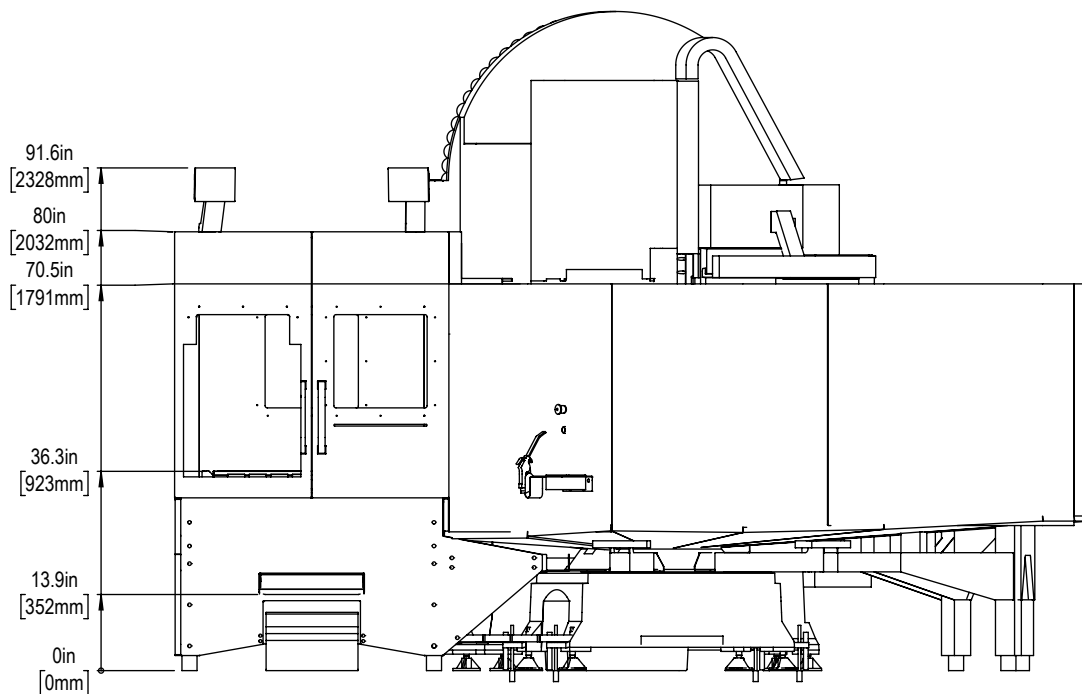

Width Breakdown

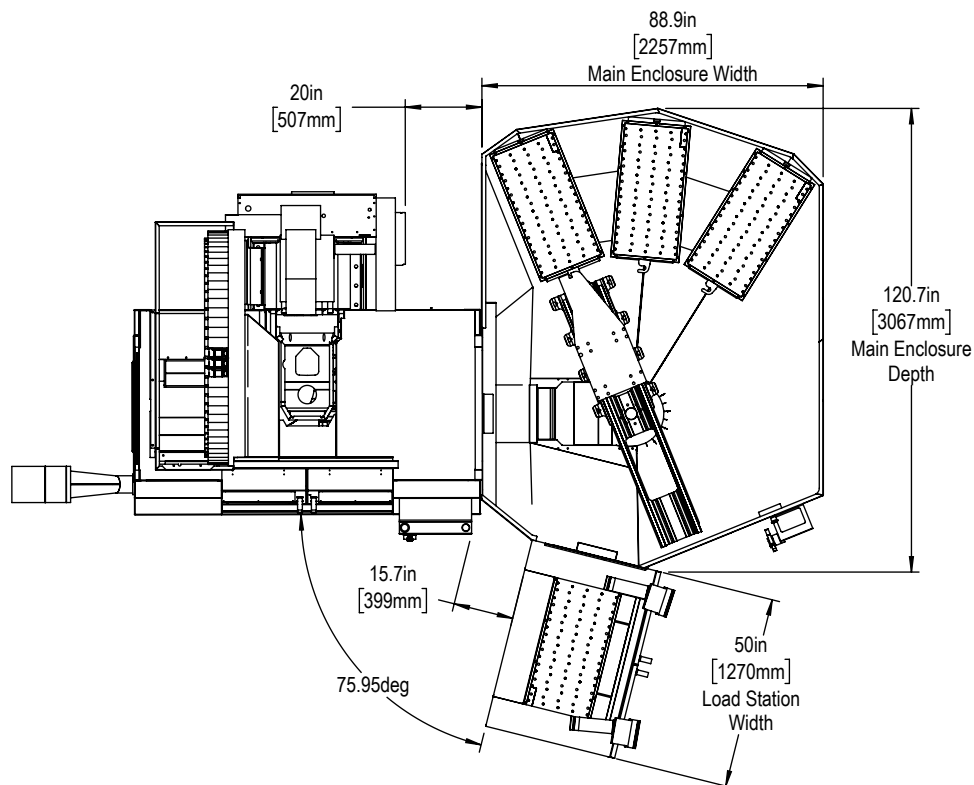

Maintain 3 feet [915mm] clearance to the nearest obstruction around all sides of machine perimeter for maintenance access

X&Y-Axis Travel

