

WireCrafters

RapidGuard™ II Installation Instructions

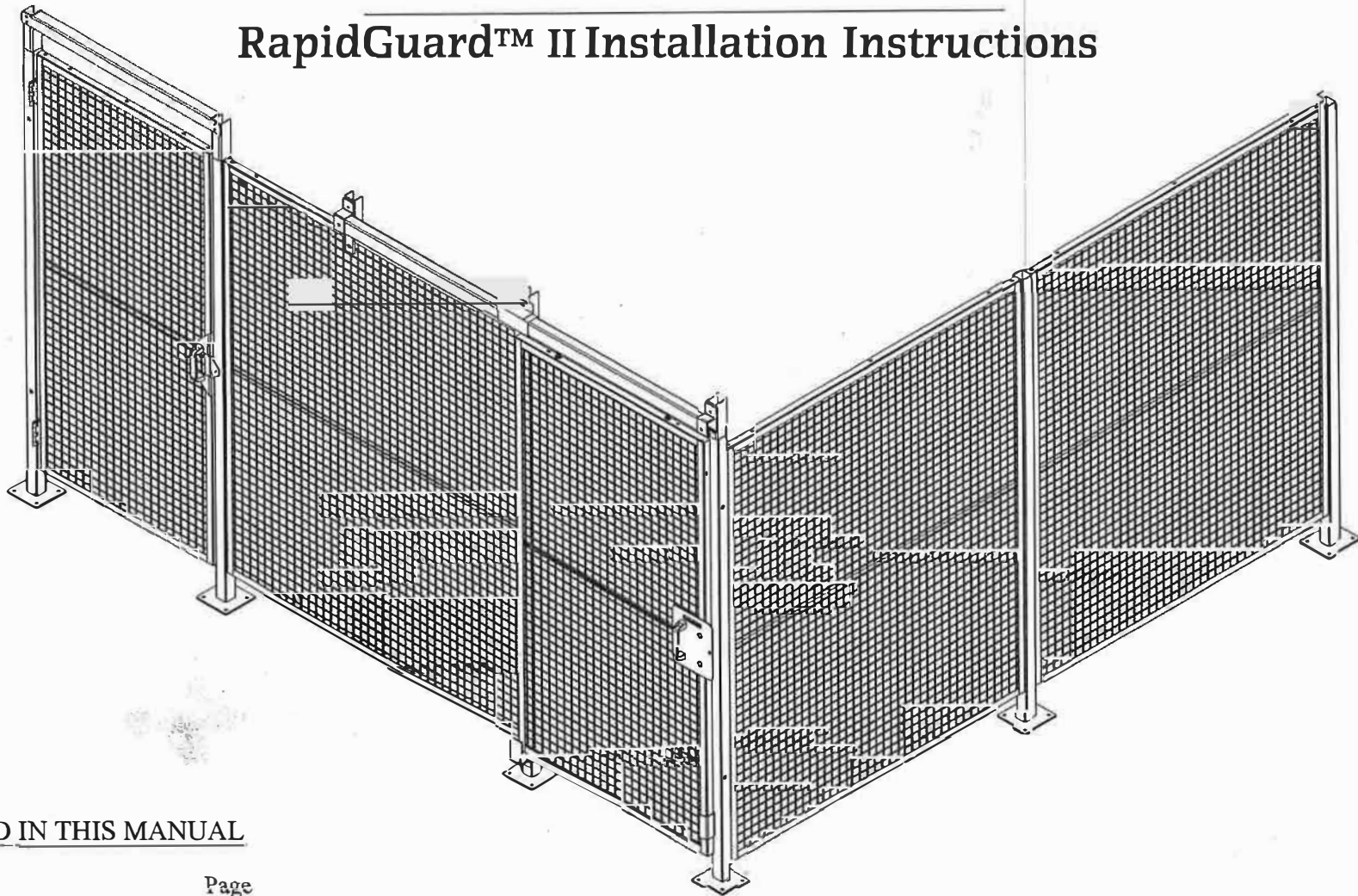

INCLUDED IN THIS MANUAL

<u>Description</u>	<u>Page</u>
General Information	2
Panels and Posts	3
Hinge Door Hardware	4
Hinge Door	5-6
Hinge Door with Transom	7
Slide Door Hardware	8
Slide Door 6' Tall	9-10
Slide Door 8' Tall Details	11
Slide Door Assembly	12

We're Here to Help
800-626-1816

WireCrafters, LLC.

General Information

6208 Strawberry Lane
Louisville, Kentucky 40214

502/363-6691
502/361-3857 FAX

www.wirecrafters.com
1-800-626-1816

These Installation Instructions are provided as a guide for assembling WireCrafters RapidGuard™II partition system. Due to varying job site conditions and infinite layout possibilities, there is no "recommended" or standard way to install the product. **Common sense and proper safety measures must be used during installation.** The product may be unstable during installation; adequate temporary bracing should be used until the layout is fully assembled with all fasteners and anchors properly tightened. Depending on site and layout conditions, permanent field bracing to building structure may be necessary. The addition of field bracing is the responsibility of and shall be done at the installer's or owner's discretion and expense. Installation problems arising from job site conditions should be referred to a professional installer. Refer product assembly questions to WireCrafters.

TOOLS RECOMMENDED

Chalk line & marker	Drill with adjustable clutch and 3/8" nut driver	(2) Step ladders
Tape Measure	Hammer Drill with 3/8" masonry bit	(2) C clamps or Vise-Grip® type clamps
Level	(2) 1/2" open-end wrenches and/or	#1 & #2 Phillips Screw Driver
Hacksaw	(2) 1/2" deep socket ratchets	9/16" deep socket or 9/16" open-end wrench
5/32" Allen Wrench	5/16" open-end wrench	3/16" Steel drill bit

SELF DRILLING SCREW INSTALLATION RECOMMENDATIONS

When installing self-drilling screws, use a standard variable speed screw gun equipped with an adjustable clutch or depth locating nose piece. Take care not to over tighten or strip, set drill accordingly. **DO NOT USE IMPACT TYPE GUN WHEN INSTALLING SELF DRILLING SCREWS.** Securely clamp component parts in place before attaching with self-drilling screws.

INSTALLER TIPS

1. The installation will be best accomplished with a one or two-person crew.
2. Before starting, review all installation instructions pertinent to your layout (i.e. panels, doors, etc.)
3. "Face Side" of the partition is the outside. "Inside" of the partition has one leg of the panel frame pointing in. Panel fastener hardware will be on the inside of the partition.
4. Panels install vertically between posts.
5. Identify all posts and panels by part number. If possible, stage parts where they will be installed.
6. Special size panels have sticker tags on the angle and are referenced on the drawing.
7. Make sure all posts are installed plumb (vertically perpendicular to the floor). Shims (not provided) may be necessary.
8. Use a 5 1/4" spacer block (not provided) to support the far end of a panel during setup.
9. Begin the installation process at a building wall, end or corner of the layout.
10. Gauge hinge door opening width by installing a header angle.
11. Gauge slide door opening by door width (e.g. 48" between posts for 4' wide slide door). When necessary, slide door openings may be narrowed to adjust the length of an adjacent run.
12. Standard hinge and slide doors are universal and may be installed left or right hand.
13. The installer should touch up all nicks, marks, and scratches with touch up paint provided.

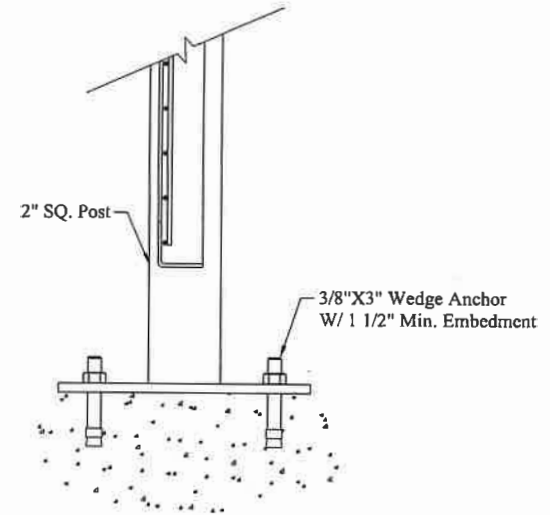
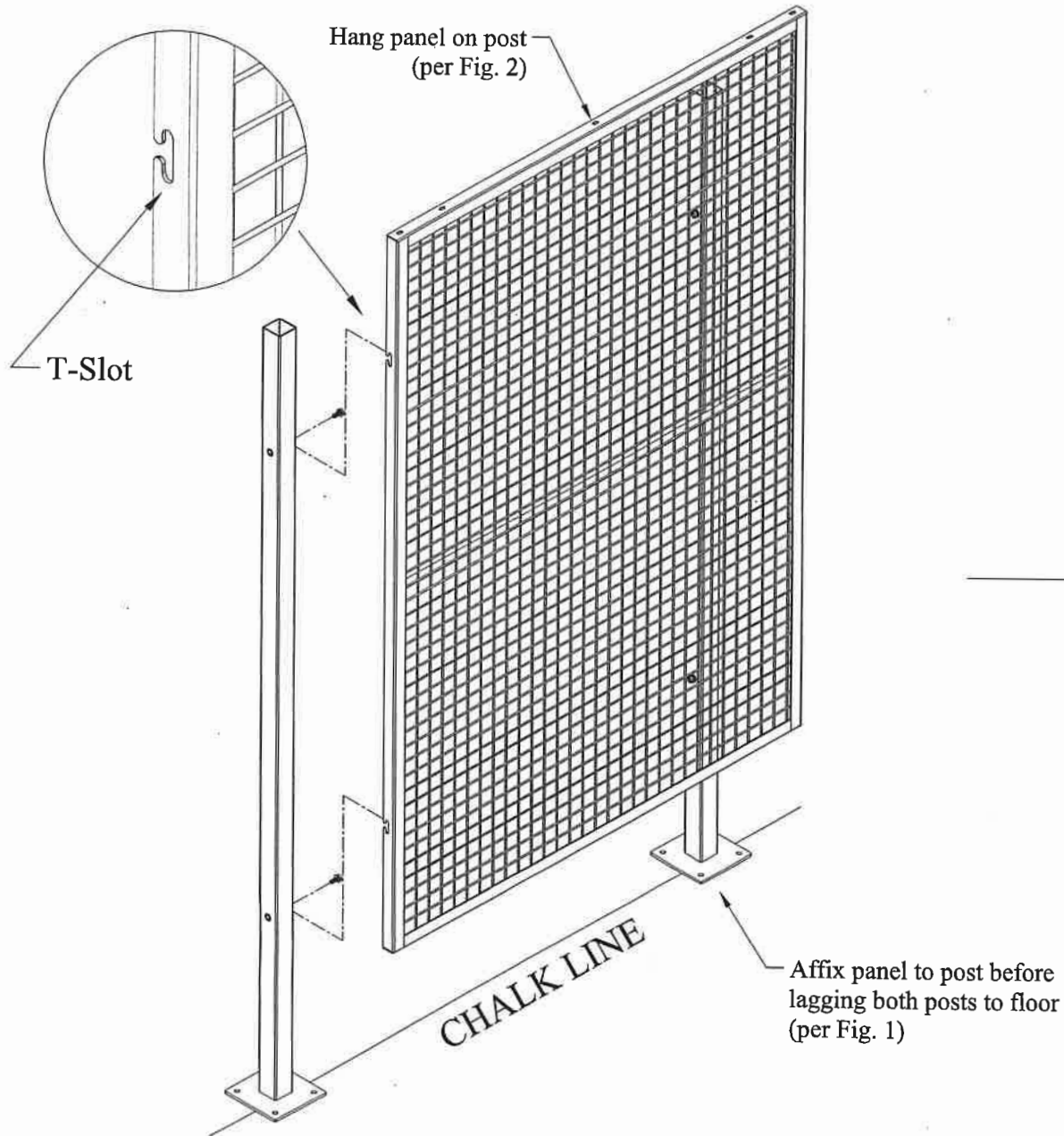

Fig.1

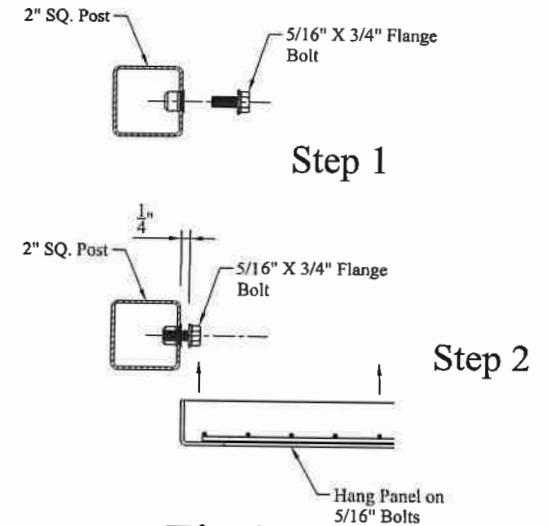
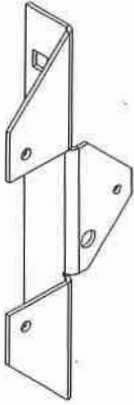
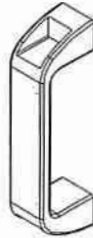

Fig.2



Bolt-On Door Handle Bracket
Quantity (1)
Part# HDPBBKTHNDL



Door Handle
Quantity (1)
Part# RGHANDLE

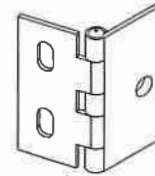

Door Hinge
Quantity (2)
Part# RTHDHG44IPL

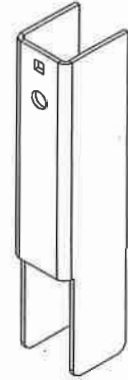

Post Extension Bracket
Quantity (2)
Part# RGTRKXMBP
Used with Header Angle
See Fig. 2 on page 5

RTHDFSPK - Fastener Pack (Contents Below)

- (2) FS1412BHSCS - 1/4"-20 Button Head Sockets
- (4) FS141CB - 1/4"-20 x 1" Carriage Bolts
- (4) FS141N - 1/4"-20 Hex Nut
- (4) FS14FW - 1/4" Flat Washer
- (2) FS381CB - 3/8"-18 x 1" Carriage Bolts
- (2) FS38N - 3/8" Hex Nut
- (8) FS38STA - 3/8" x 3" Wedge Anchor
- (24) FS51634CB - 5/16" x 3/4" Carriage Bolts
- (4) FS516FN - 5/16" Flange Nuts
- (1) HDPBMAG - Bolt-On Magnet
- (1) HDPBMAGANUT - M6-1.0 Stainless Steel Acorn Nut
- (1) HDPBMAGWSHR - Bonded Sealing Washer

Note: 6' High Post Shown
See Page 7 for 8' High Post

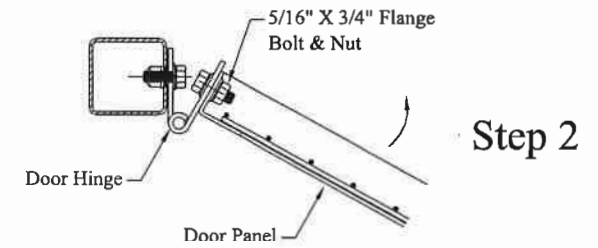
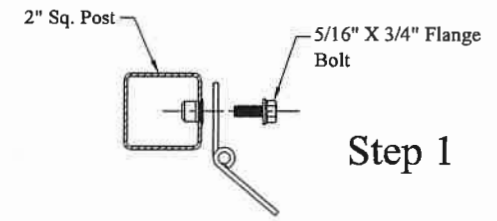
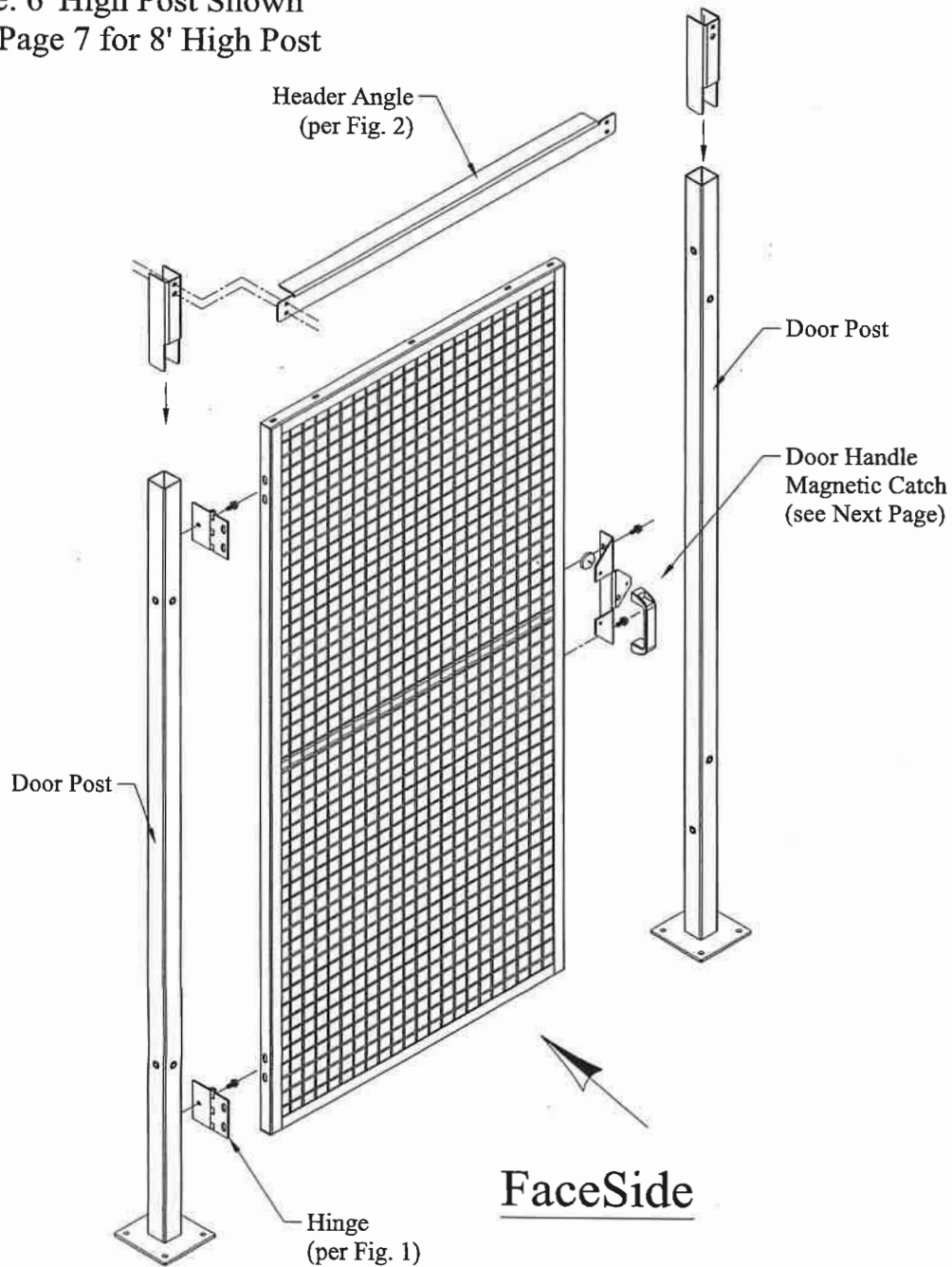
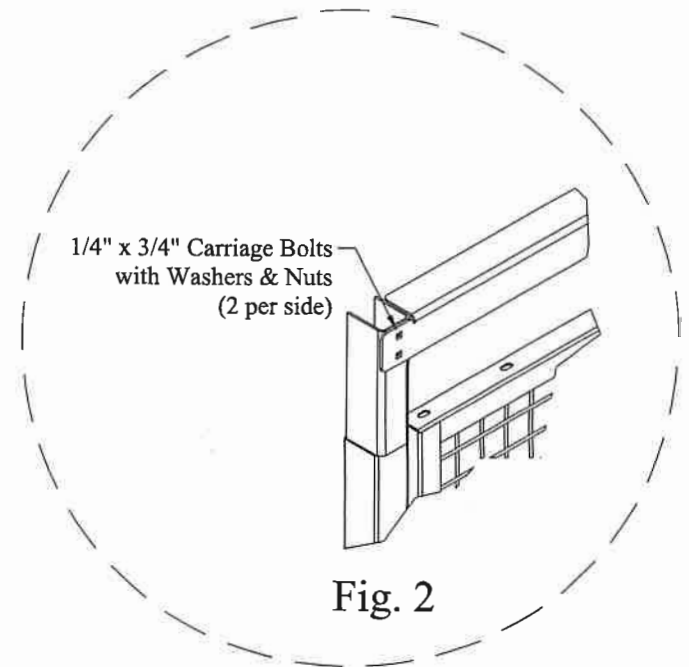
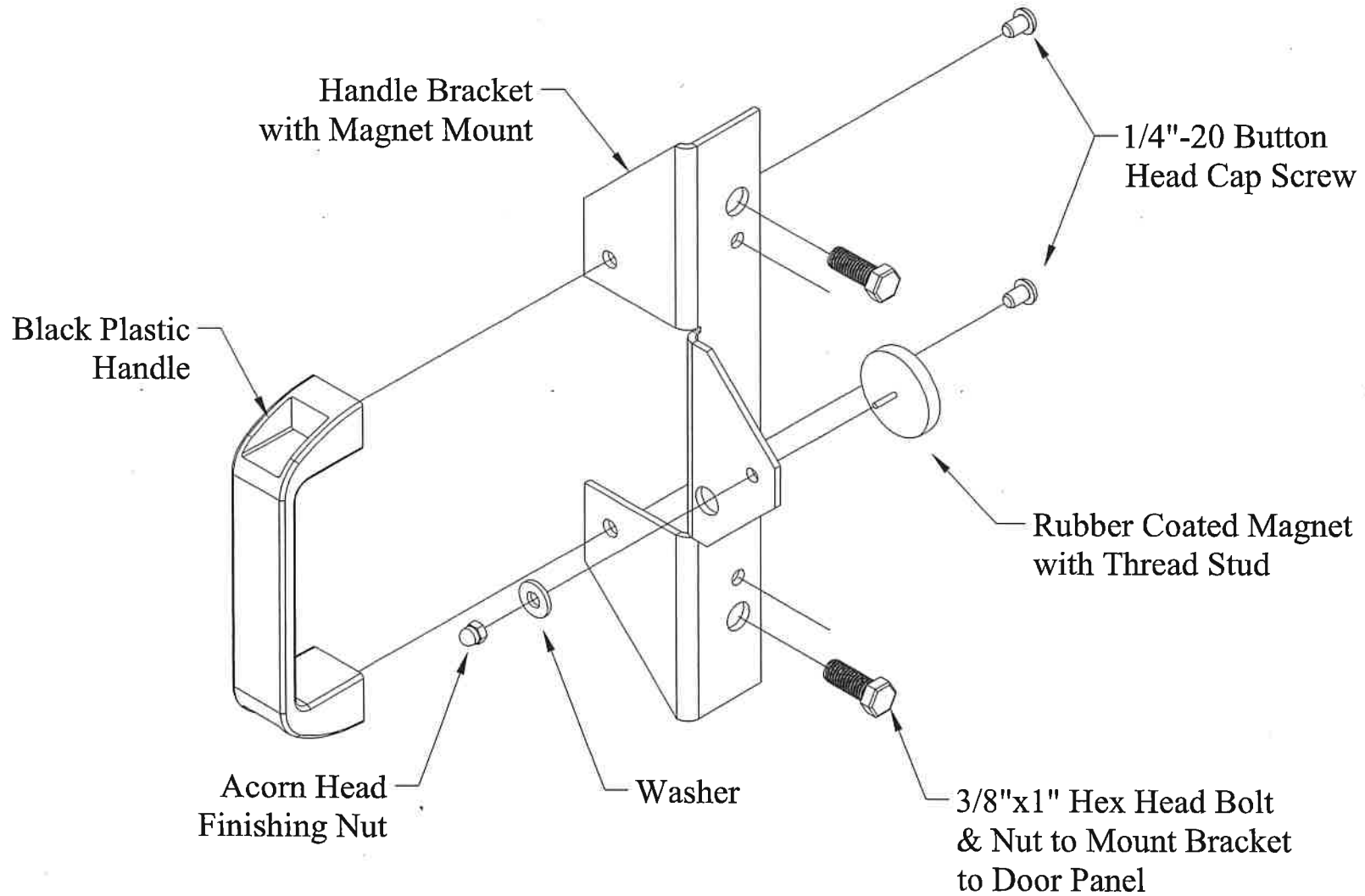
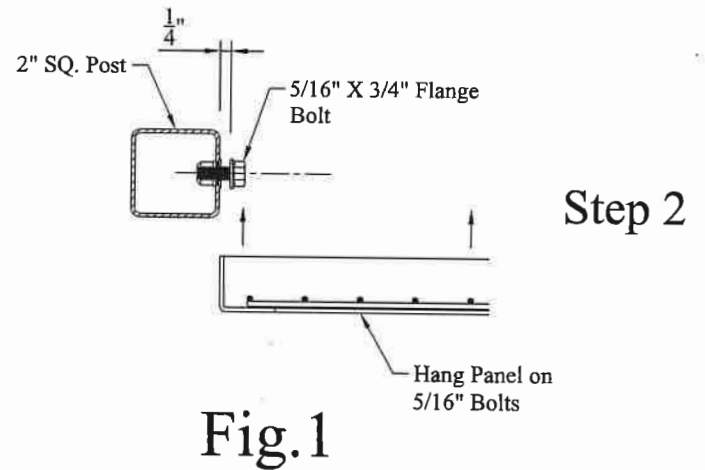
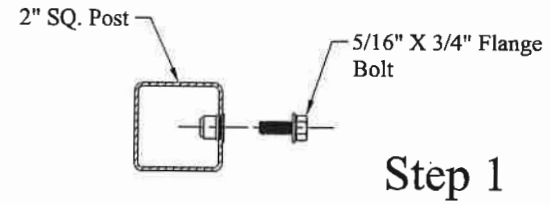
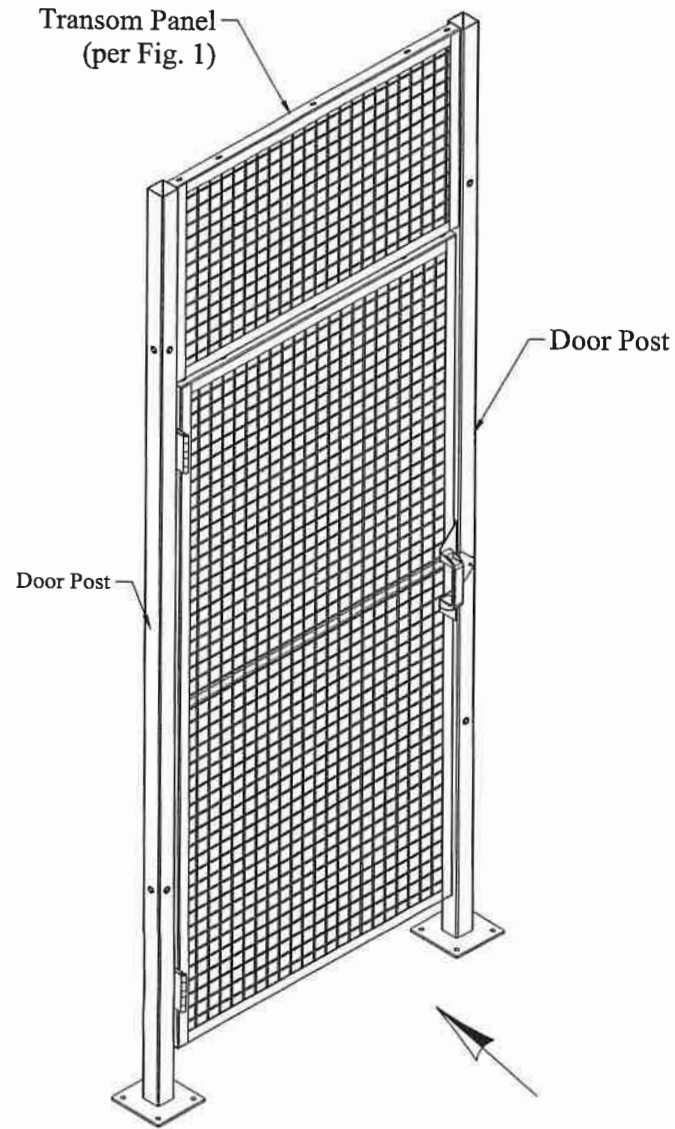

Fig. 1





Note: 8' High Post Shown
See Page 5 for 6' High Post



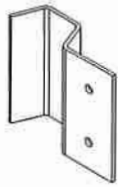

Keeper Plate
Quantity (1)
Part# RGSDKI

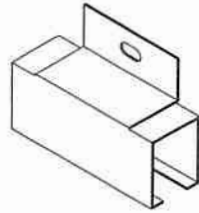

Splice Track Bracket
Quantity (1)
Part# SDTJBKT

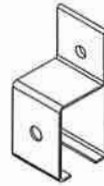

Slide Door Track Bracket
Quantity (2)
Part# SDTCBKT



4 Wheel Trolley Truck
Quantity (2)
Part# SDTT4WH



Door Guide
Quantity (1)
Part# RGSDGBO



Slide Door Catch Bracket
Quantity (1)
Part# RGSDCBKT

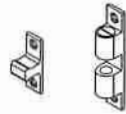

Door Catch
Quantity (1)
Part# RGCATCH

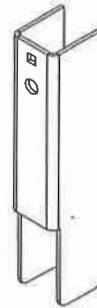

Post Extension Bracket
Quantity (2)
Part# RGTRKXMBP



Panel Extension Bracket
Quantity (1)
Part# RGTRKXMB

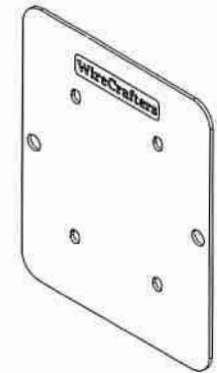

Door Plate
Quantity (1)
Part# RGDRPLT

RGSDFSPK - Fastener Pack (Contents Below)

- (4) FS1412BHSCS - 1/4"-20 Button Head Sockets
- (6) FS14SDST - 1/4"-14 x 1" Self-Drilling & Tapping Screw
- (3) FS381 - 3/8" x 1" Hex Head Cap Screw
- (1) FS381CB - 3/8" x 1" Carriage Bolts
- (1) FS38234STB - 3/8" x 2 3/4" Carriage Bolts
- (10) FS38FW - 3/8" Flat Washer
- (1) FS38LN - 3/8"-16 Nylon Insert Lock Nut
- (6) FS38N - 3/8" Hex Nut
- (8) FS38STA - 3/8" Wedge Anchor
- (2) FS5161CB - 5/16" x 1" Carriage Bolts
- (8) FS51634FB - 5/16" x 3/4" Flange Hex Head Bolt
- (4) FS63238FHMS - #6 Phillips Flat Head Machine Screws
- (4) FS632FN - #6 Flange Nuts
- (1) RGAPFL - Adjustable Panel Flat
- (1) RGCATCH - Ball Style Tension Catch
- (1) RGHANDLE - Black Plastic Handle
- (1) RGSDCBKT - Slide Door Catch Bracket
- (2) SUD516LN - 5/16"-18 Lock Nut
- (1) FS38112 - 3/8" x 1 1/2" Hex Head Cap Screw



Flat
Quantity (1)
Part# RGAPFL



Door Handle
Quantity (1)
Part# RGHANDLE



Slide Door Shim
Quantity (2)
Part# RTSDSCH412238

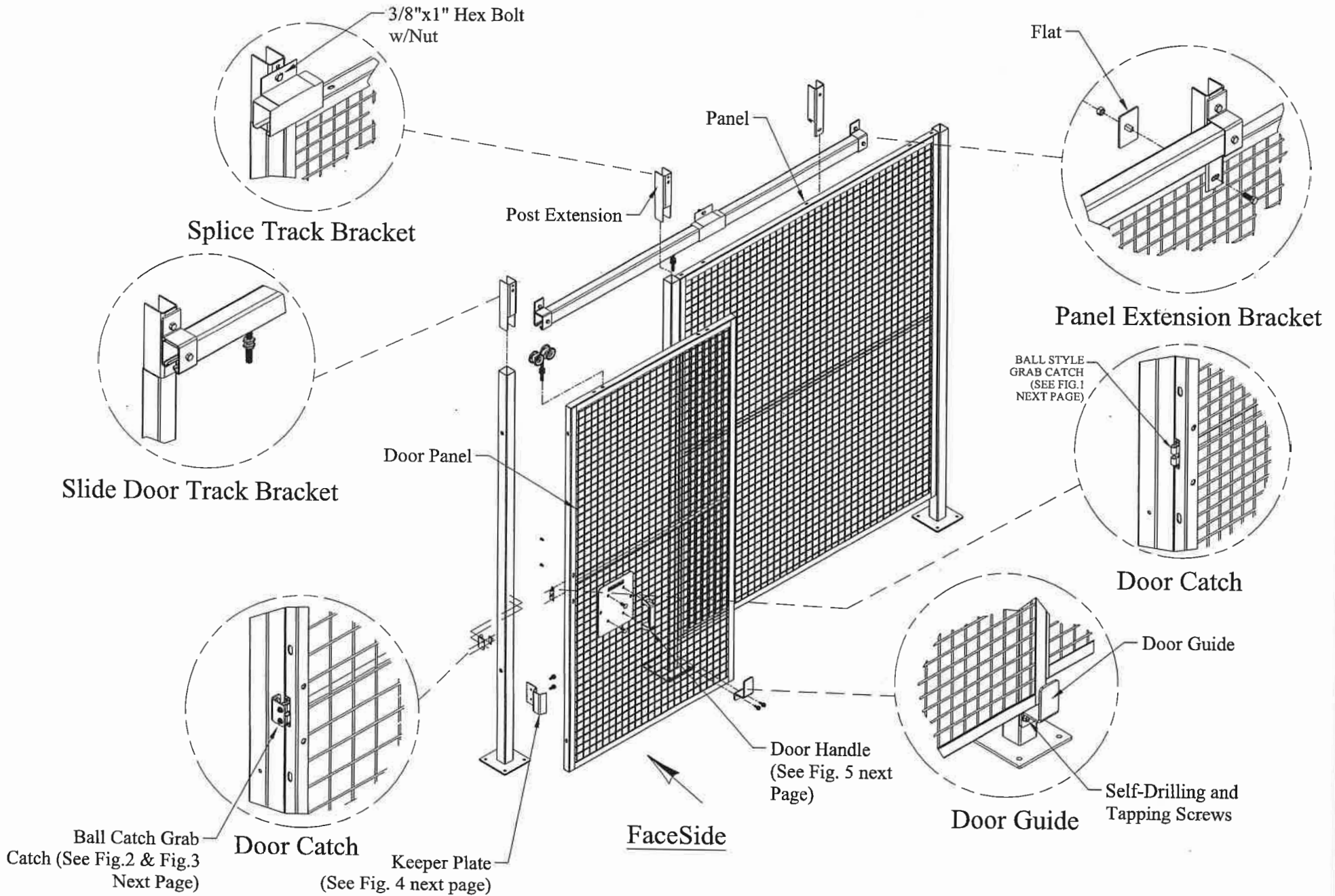

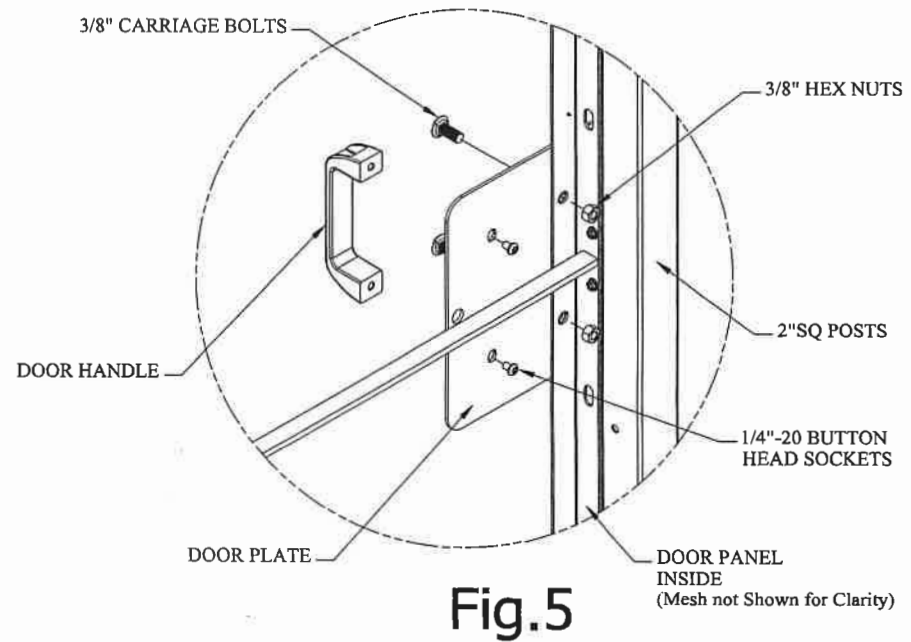
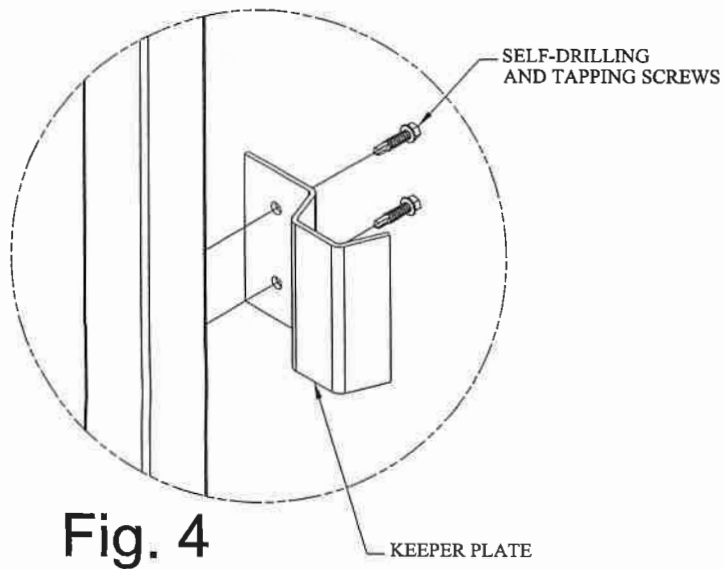
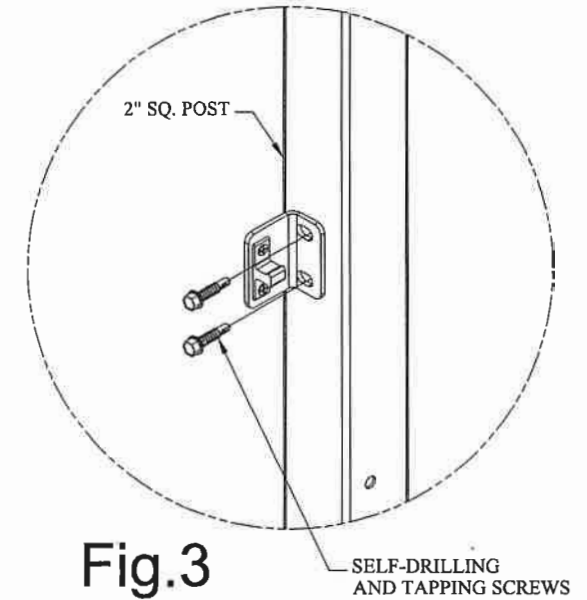
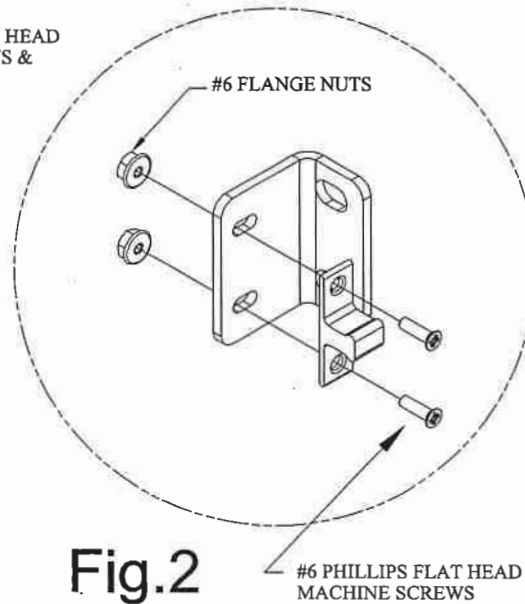
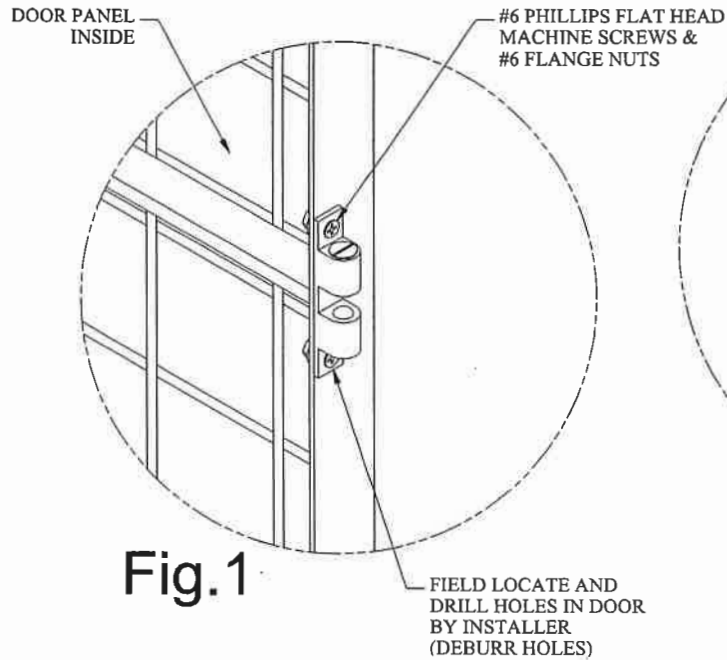

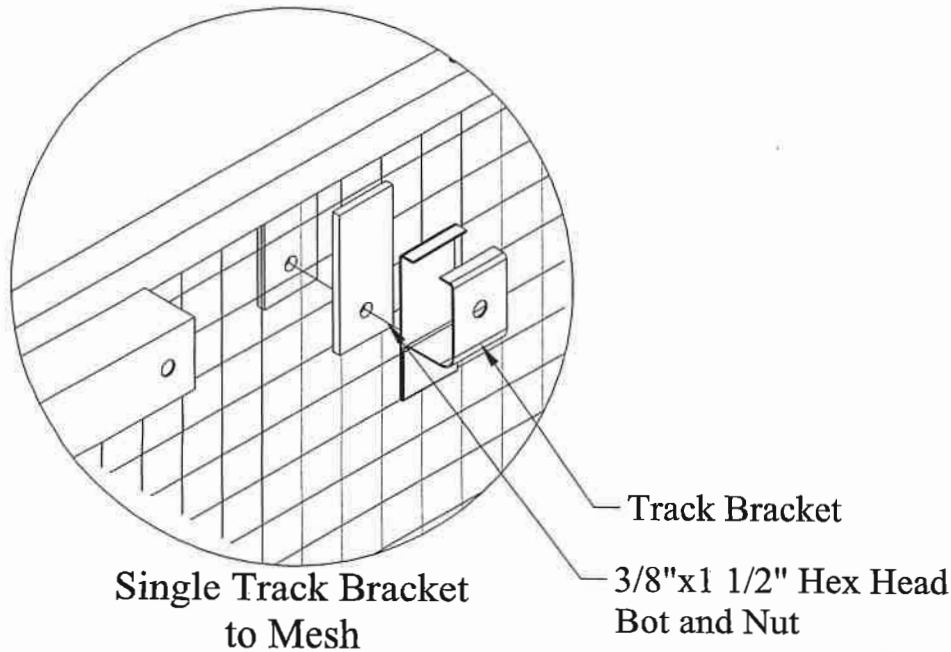
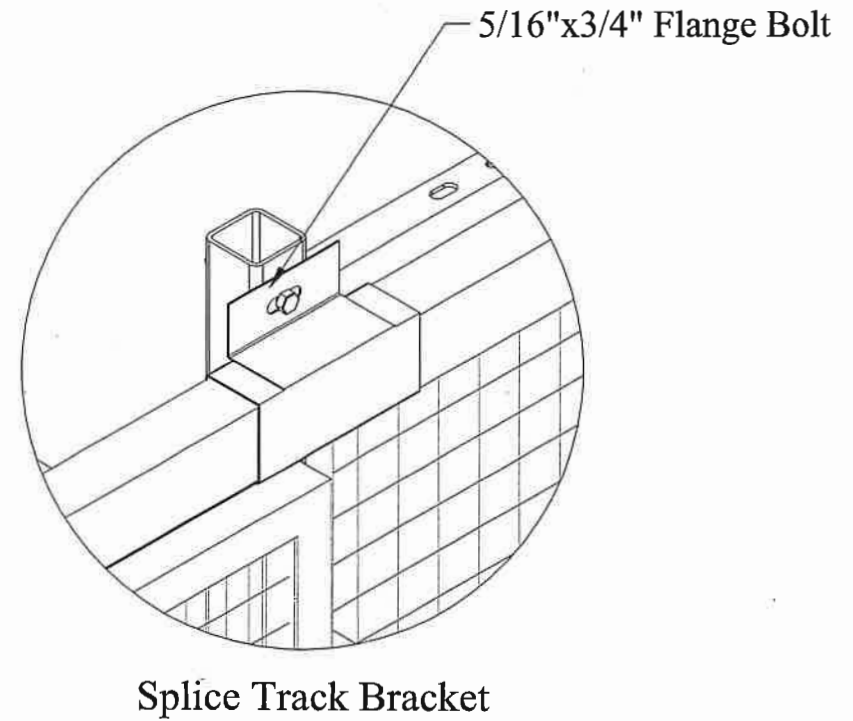
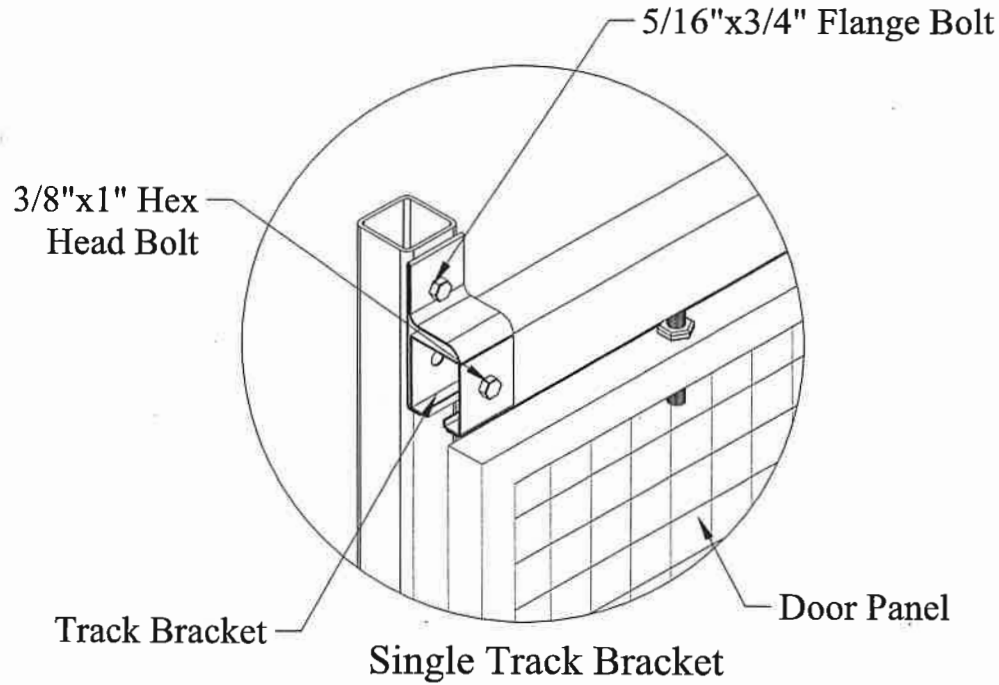

Installer Note:

This page is for instructions on track bracket for 8' tall Doors. See page 9 & 10 for all other details.

NOTE: Part (C) Door Extension Panels
for Doors Over 8' Tall

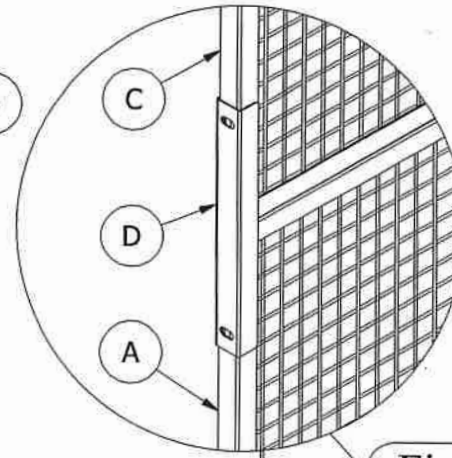
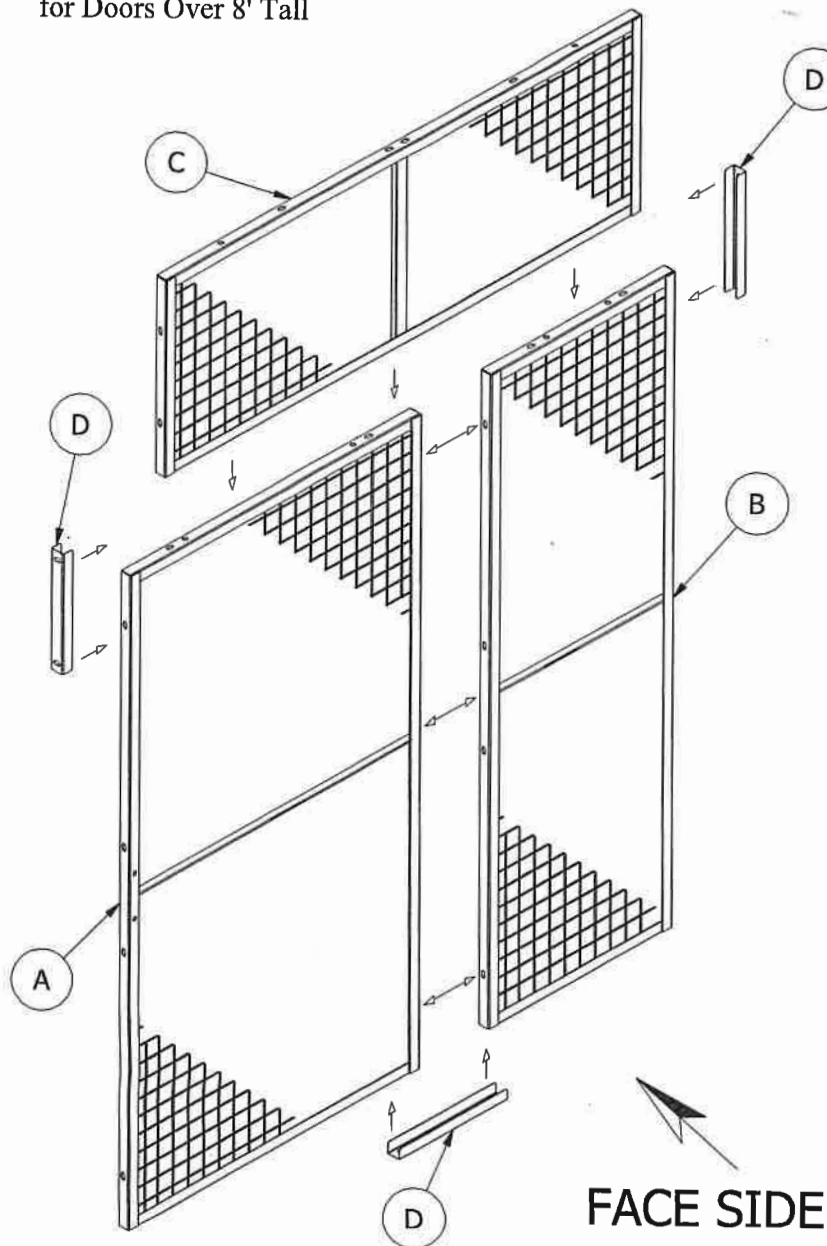

8' High Doors

Fig.1

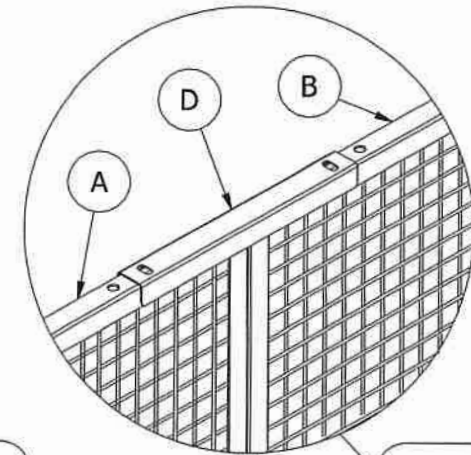

6' High Doors

Fig.2

SLIDE DOOR PANEL ASSEMBLY

- (1) Attach door panel (A) to leaf panel (B) with 3/8"x1" carriage bolts.
- (2) For doors over 8' high, attach Door Extension Panel (C)
 - a. Attached two 18" DEP Channels (D) with 3/8"x1" carriage bolts to splice connection between door and Door Extension Panel see Fig. 1.
- (3) For 6' high doors, attach one 18" DEP Channel (D) per joint to top frame with 3/8"x1" carriage bolts. See Fig.2.
- (4) Attach lower DEP Channel (D) to bottom of door with 3/8"x1" carriage bolts and nuts.