

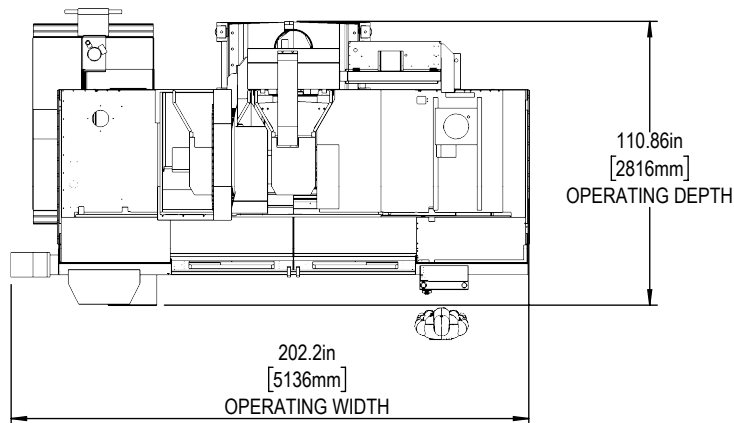

* Add 8in for Extended Z-Clearance Option

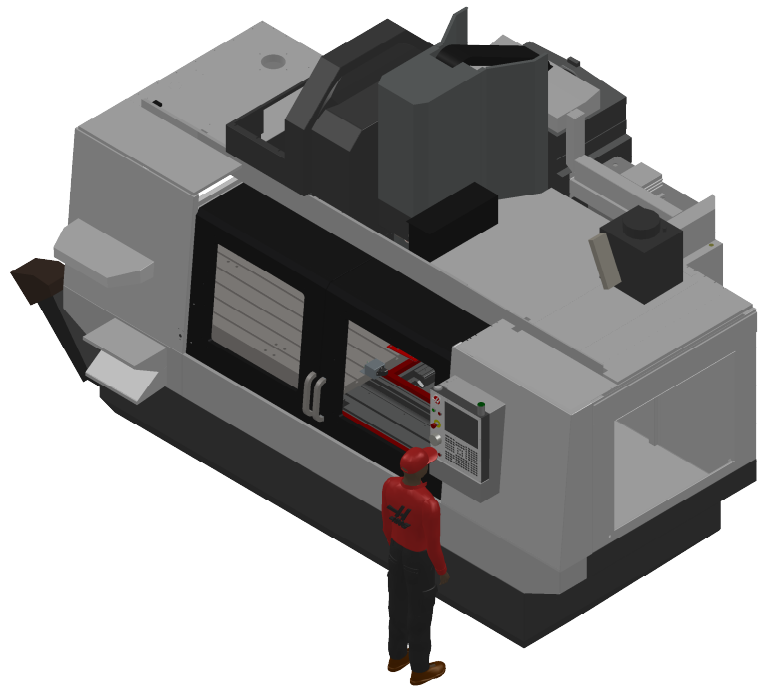

Leveling Pad Height

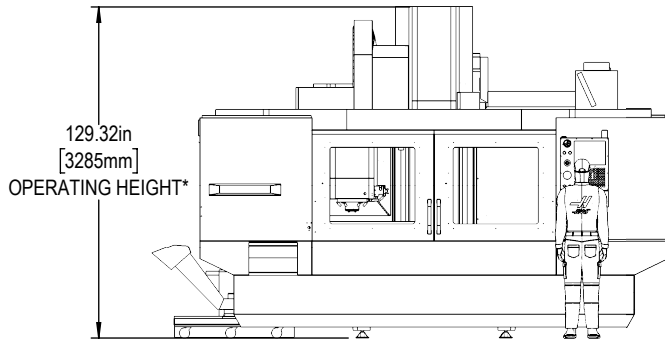
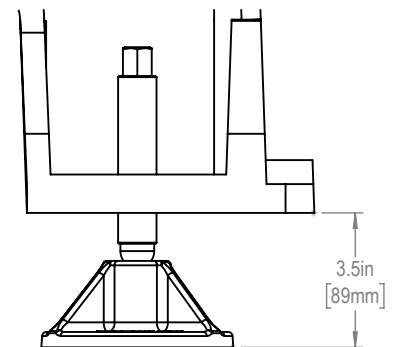

*All Height Dimensions Based on Suggested Leveling Pad Height

Shipping Dimensions

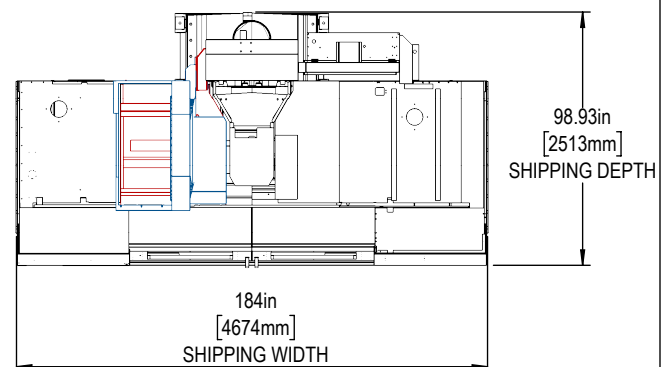
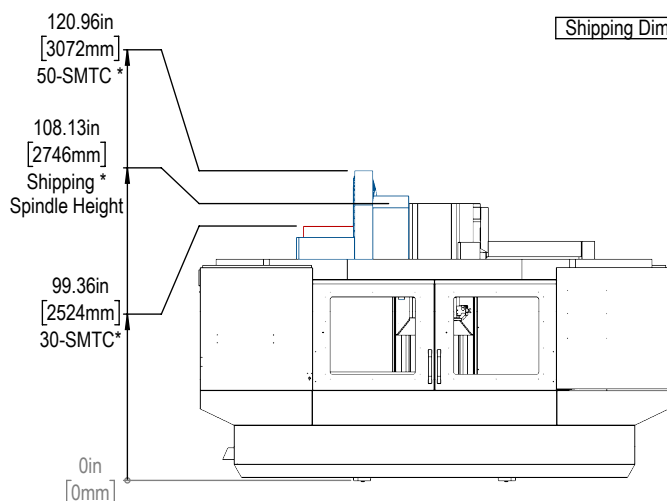

Air & Power

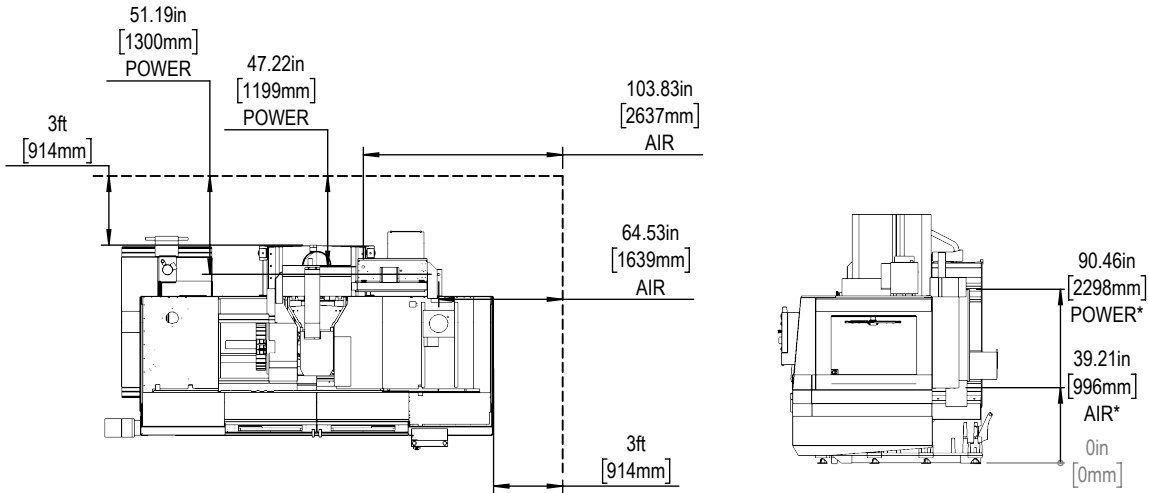

Maintain 3 feet [915mm] clearance to the nearest obstruction around all sides of machine perimeter for maintenance access

Anchor Pattern

For machines built before Sept. 2023.

NOTE: For machines built after Sept. 2023, see separate Anchoring Template.

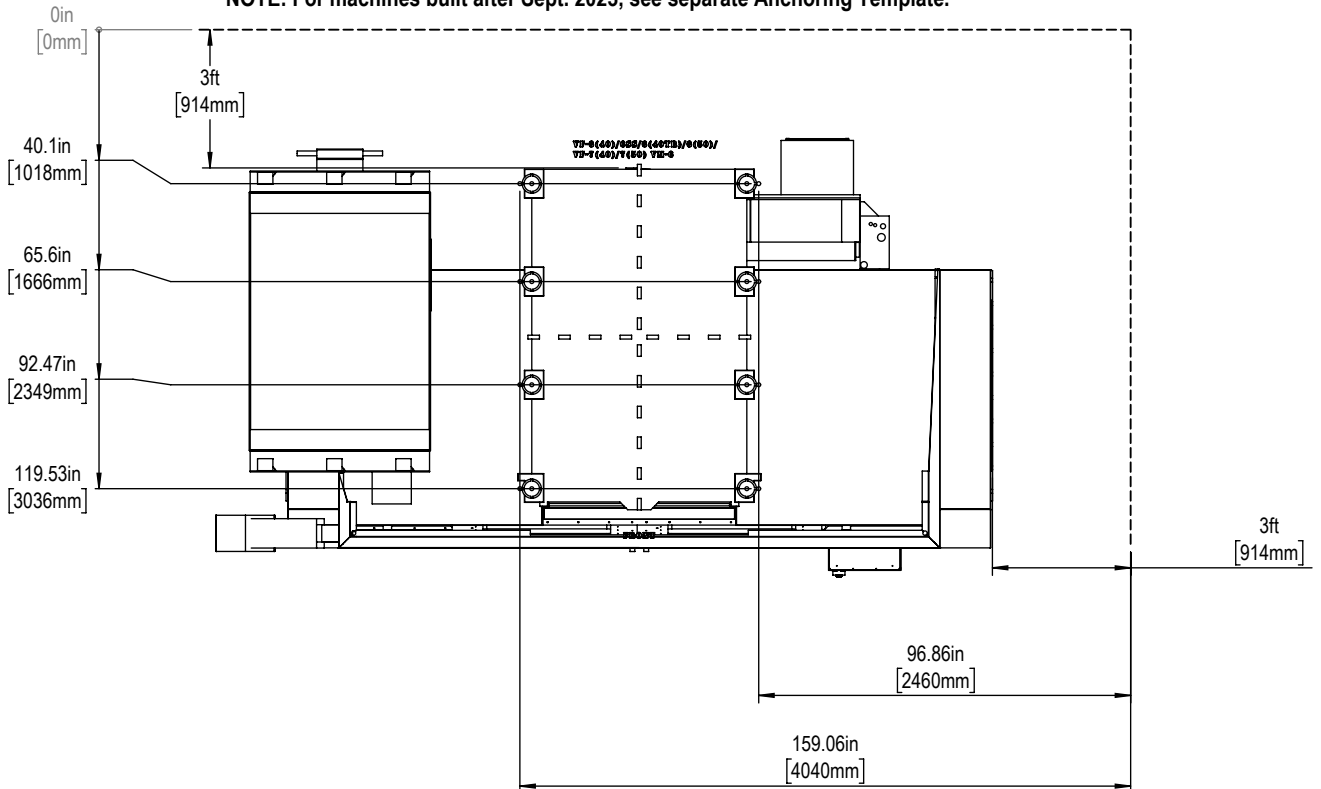

For precise locations and specifications please use template included in the Anchoring Kit and instructions found on Haascnc.com



Height Breakdown

* Add 8in for Extended Z-Clearance Option

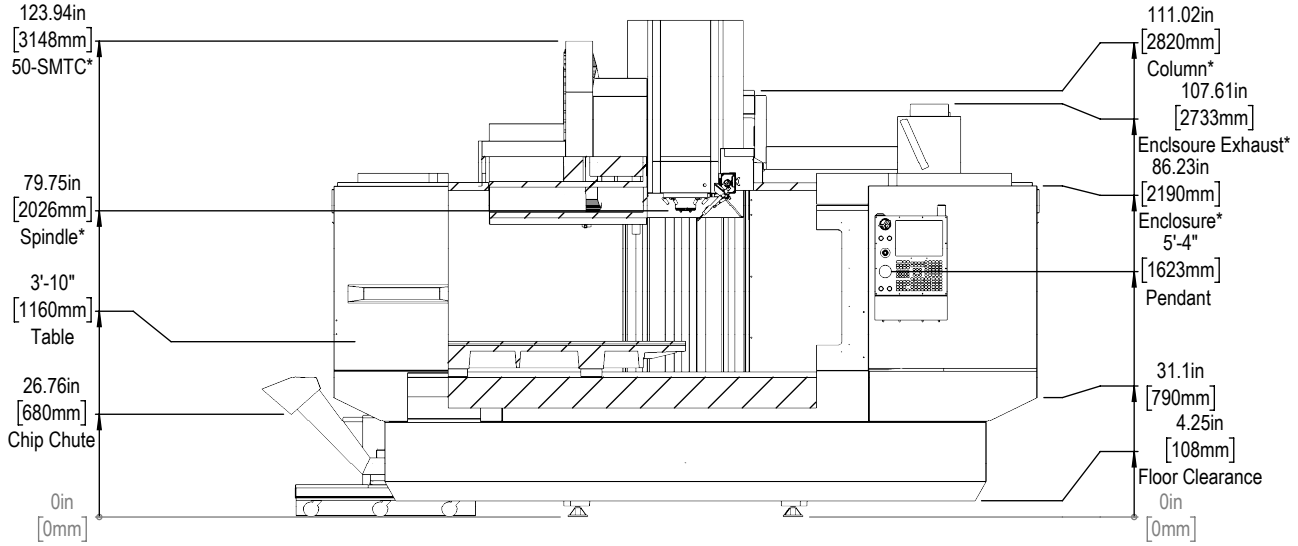

Width Breakdown

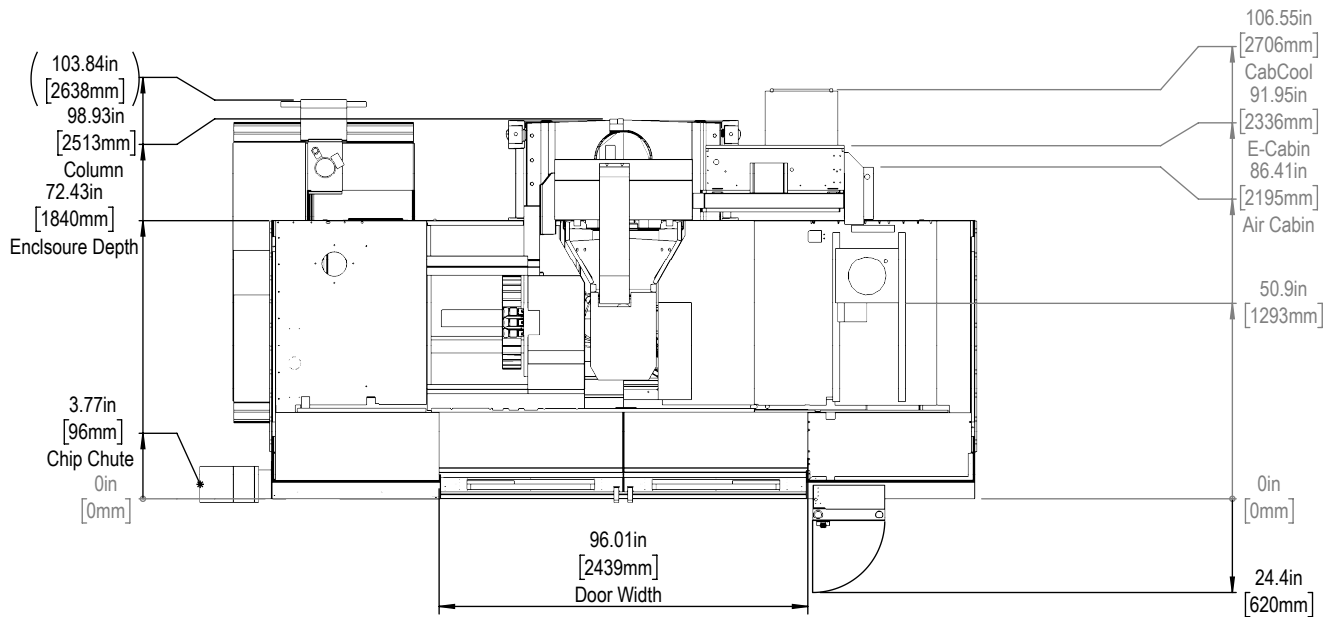



X&Y-Axis Travel and Clearance

* Add 8in for Extended Z-Clearance Option

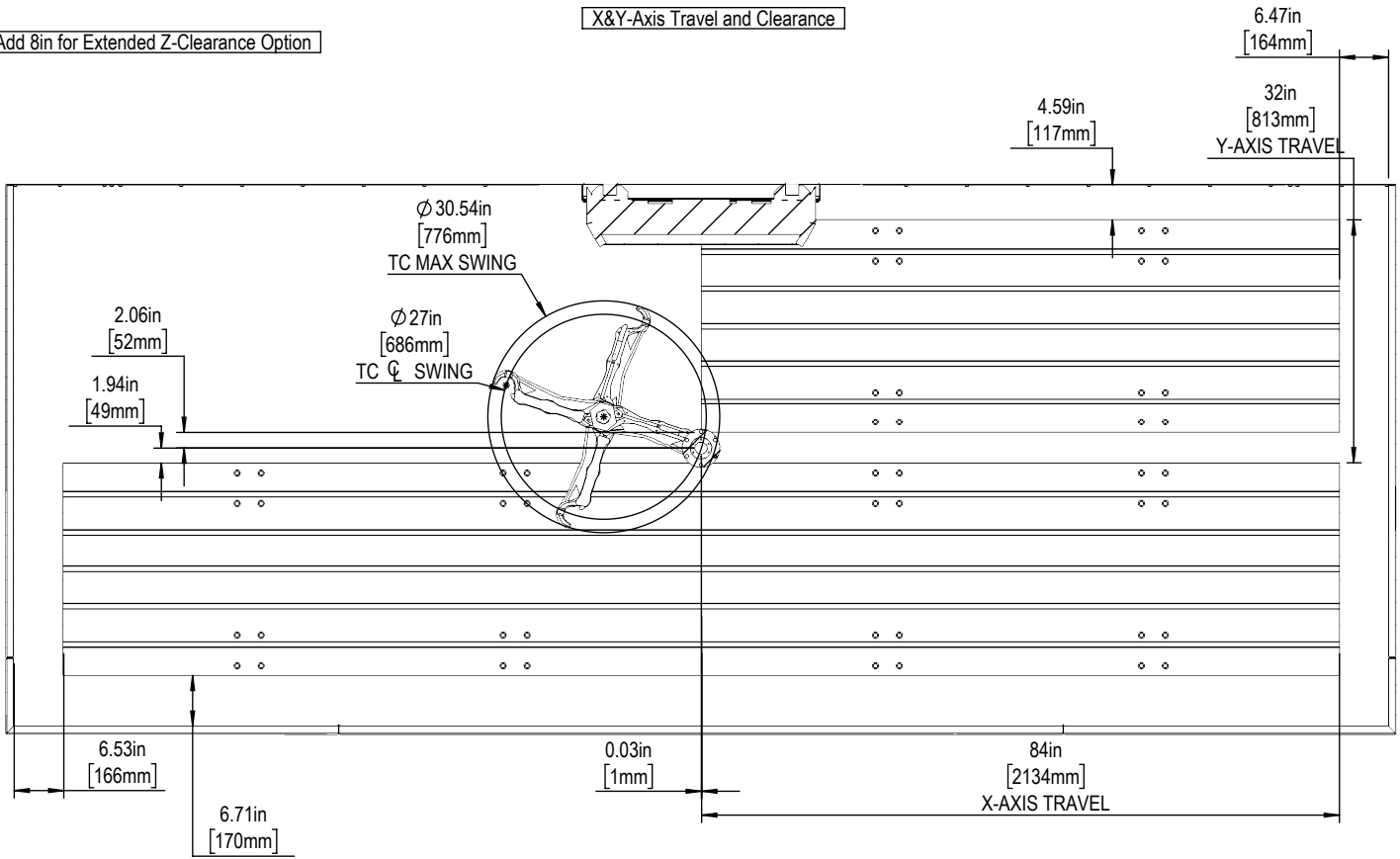

Z-AXIS TRAVEL & CLEARANCE

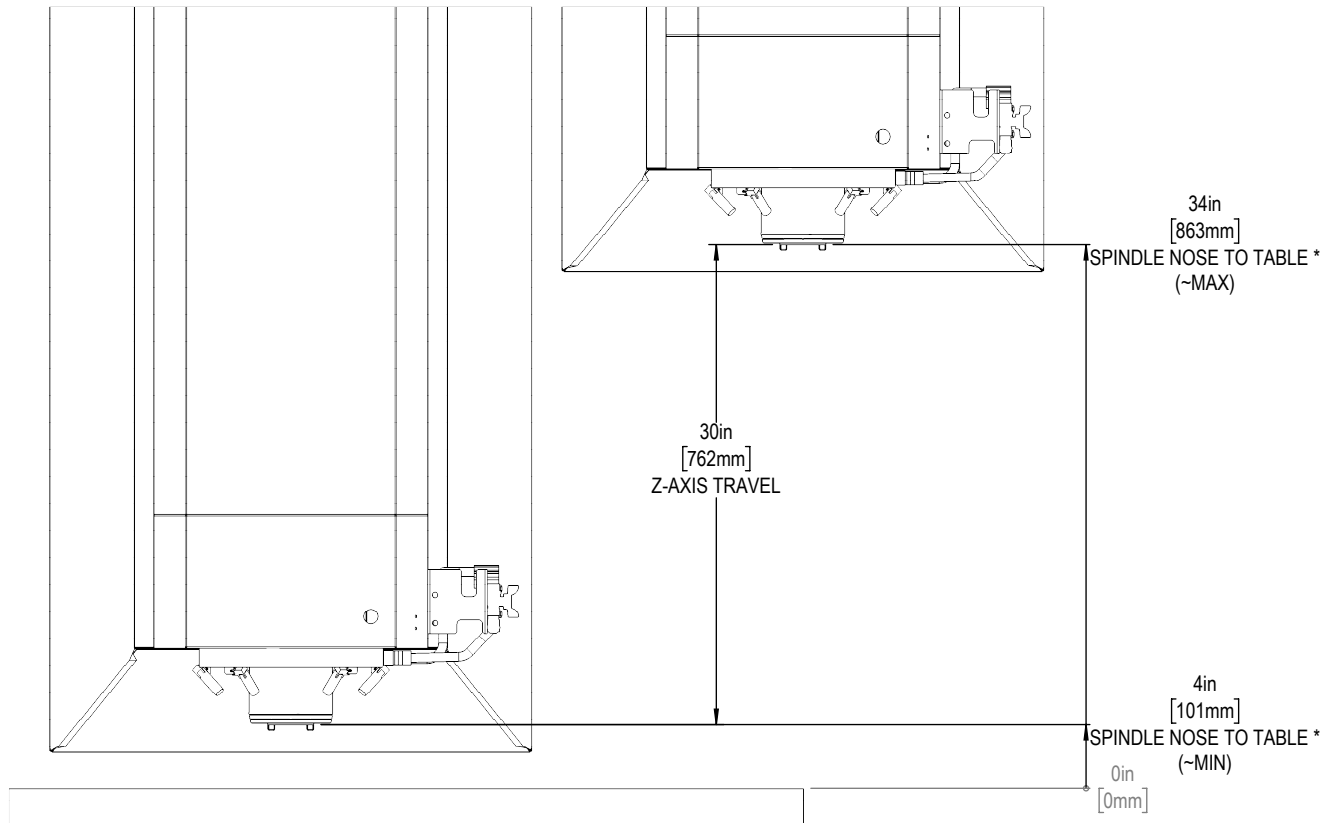



Table

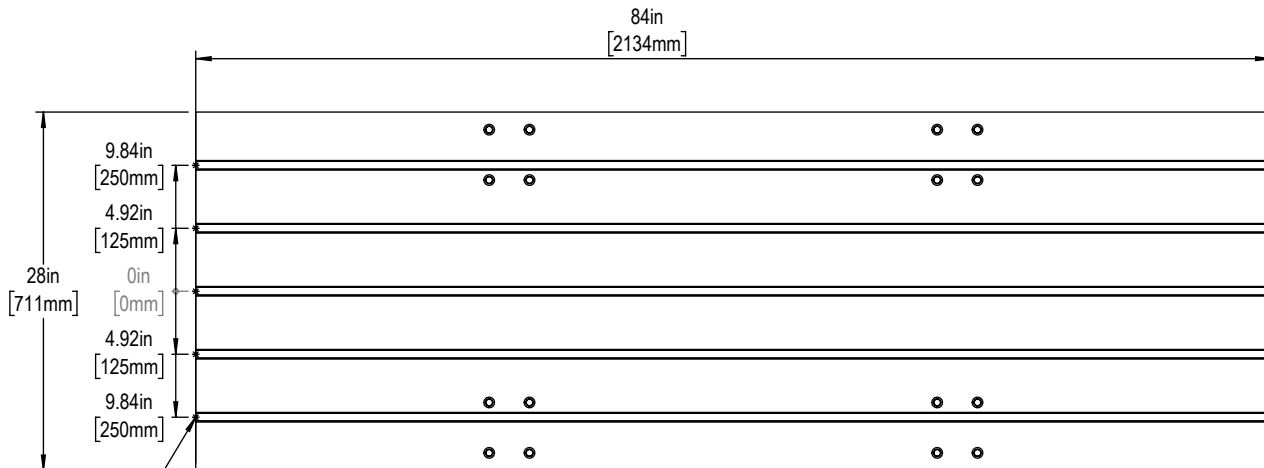

16mm T-SLOTS

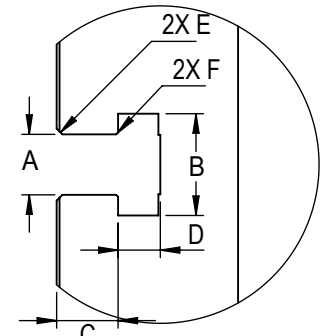

T-Slot Dimensions in inches

Slot Size	A	B	C	D	E	F
12mm	0.438 ^{+0.002} / _{-0.000}	0.76 ± 0.02	0.310 ± 0.010	0.318 ± 0.010	0.03x45°	0.020x45°
16mm	0.628 ± 0.002	1.06 ± 0.02	0.640 ± 0.010	0.420 ± 0.010	0.06x45°	0.020x45°

* Add 8in for Extended Z-Clearance Option

Tool Changer

