

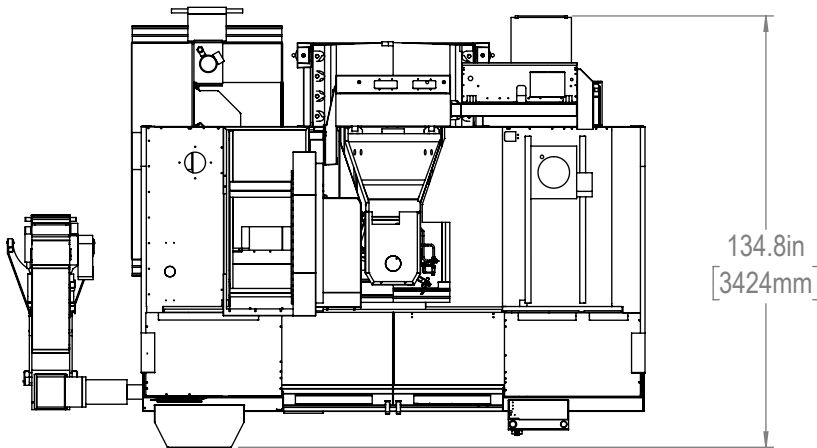

Installed Dimensions

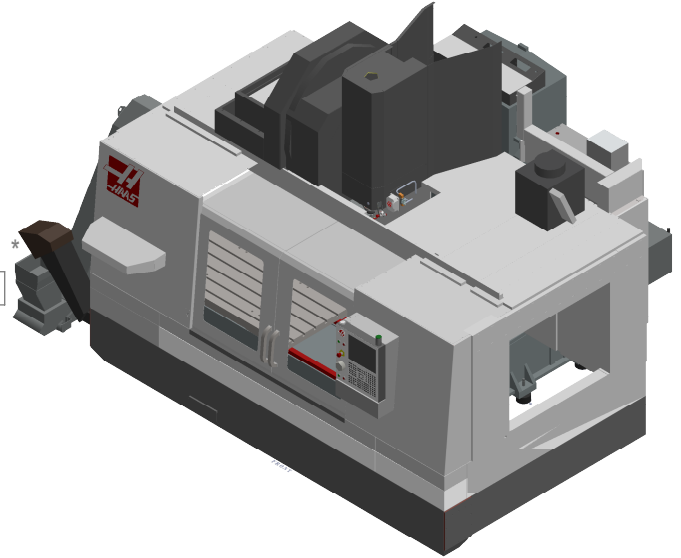
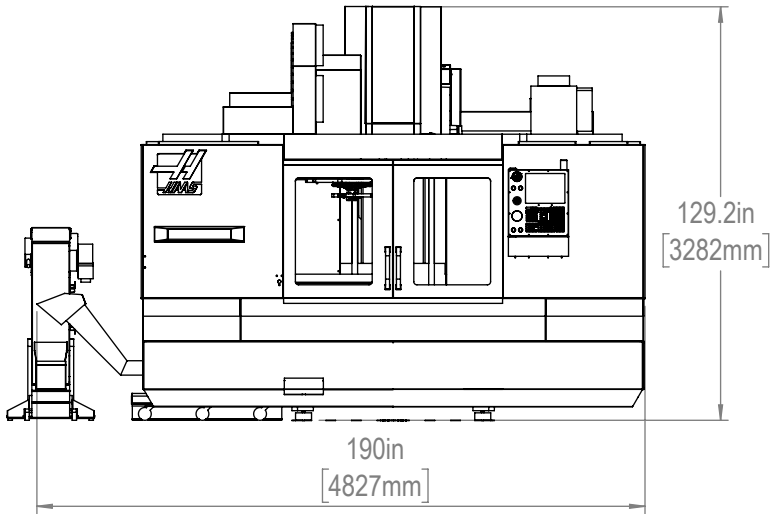

NOTE: 8" EXTENDED Z-AXIS CLEARANCE OPTION
ADDS 8" (203mm) TO DIMENSIONS WITH *

Leveling Pad Height

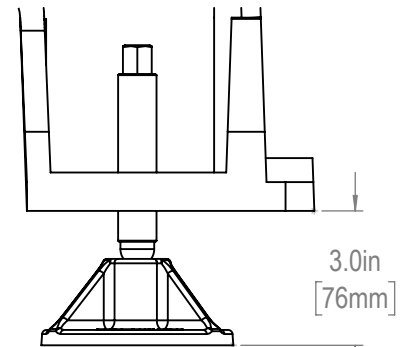

*All Height Dimensions Based on Suggested Leveling Pad Height

Shipping Dimensions

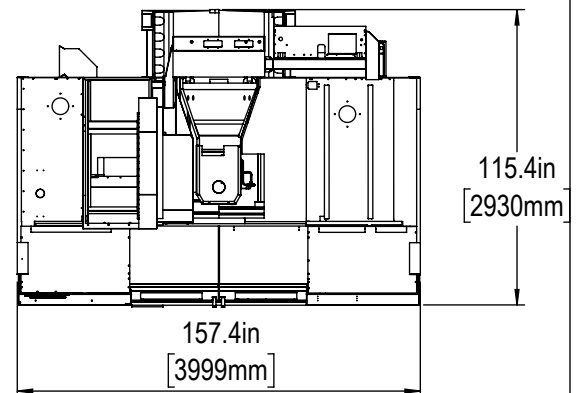
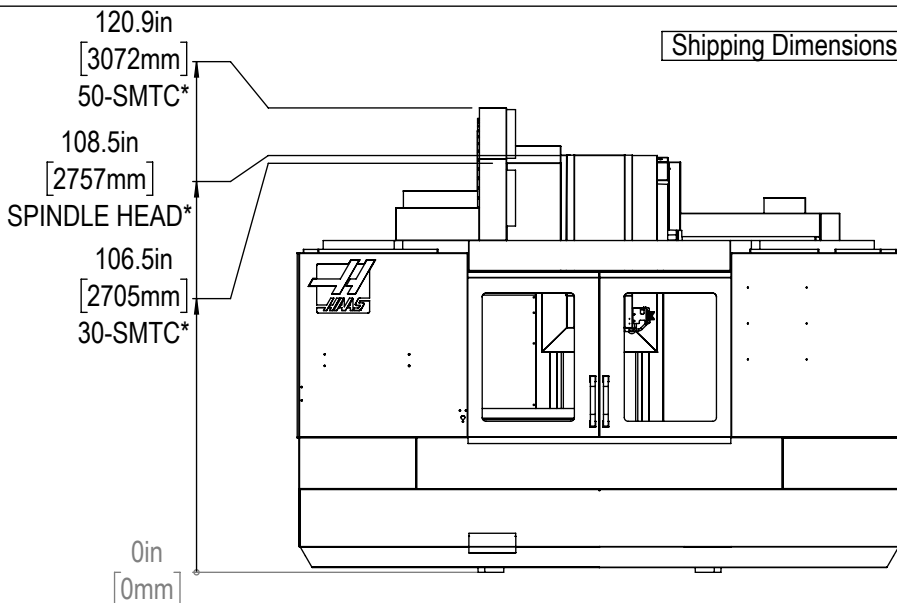

Air & Power

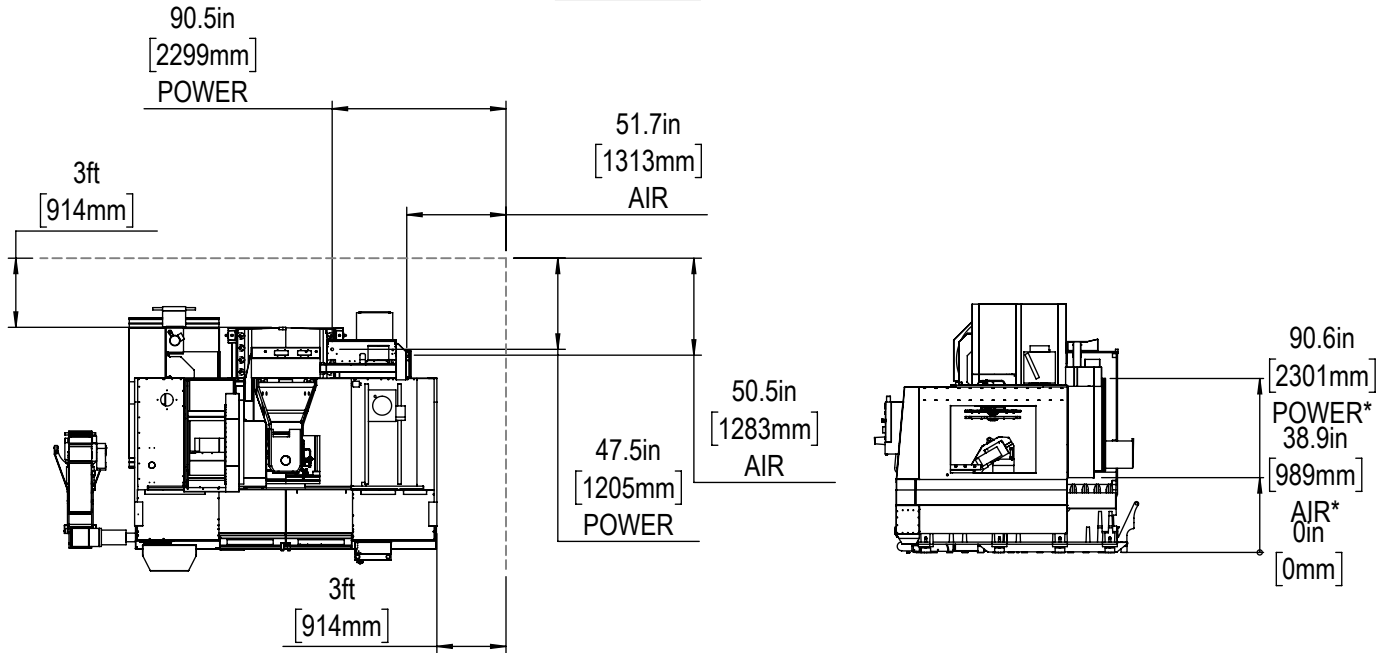

Maintain 3 feet [915mm] clearance to the nearest obstruction around all sides of machine perimeter for maintenance access

Note:
Machine must be placed on one continous concrete slab. Slab should extend 12in [305mm] beyond anchor holes in all directions

Anchor Pattern

For machines built before Sept. 2023.

Anchor Hole Detail
 \varnothing 0.625in[16mm]
 ∇ 1.0in[25mm]

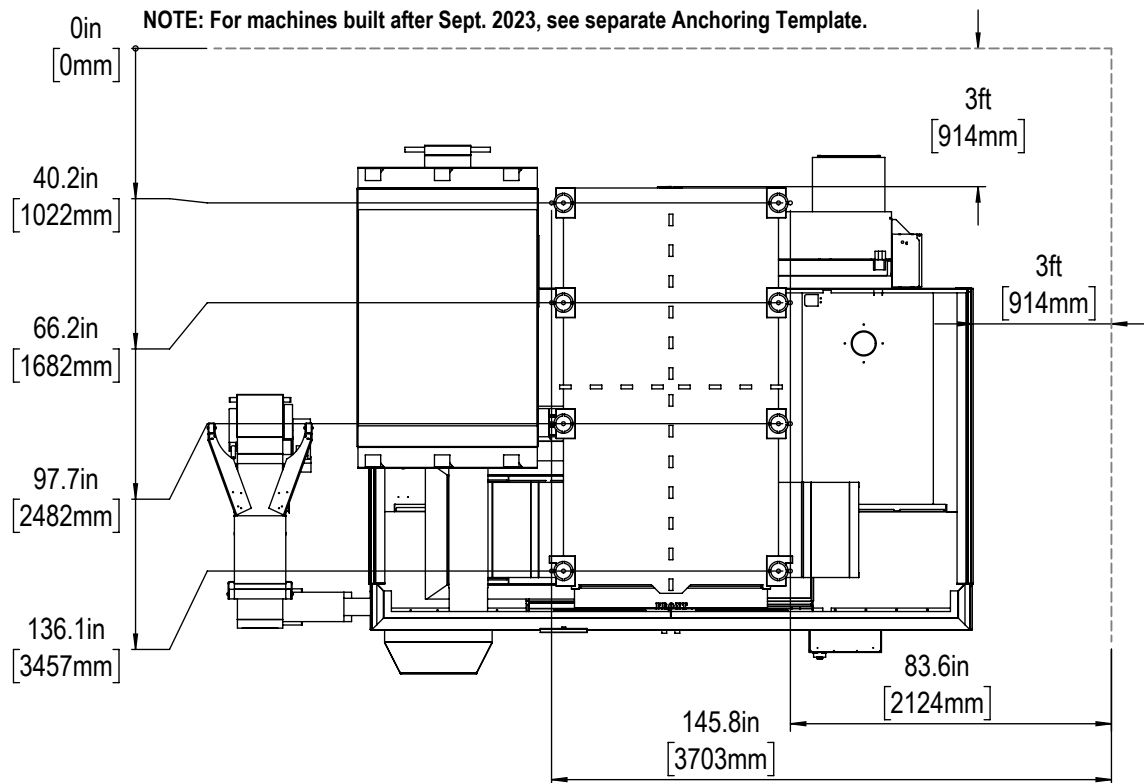

For precise locations and specifications please use template in Anchoring Kit found at Haascnc.com



Height Breakdown

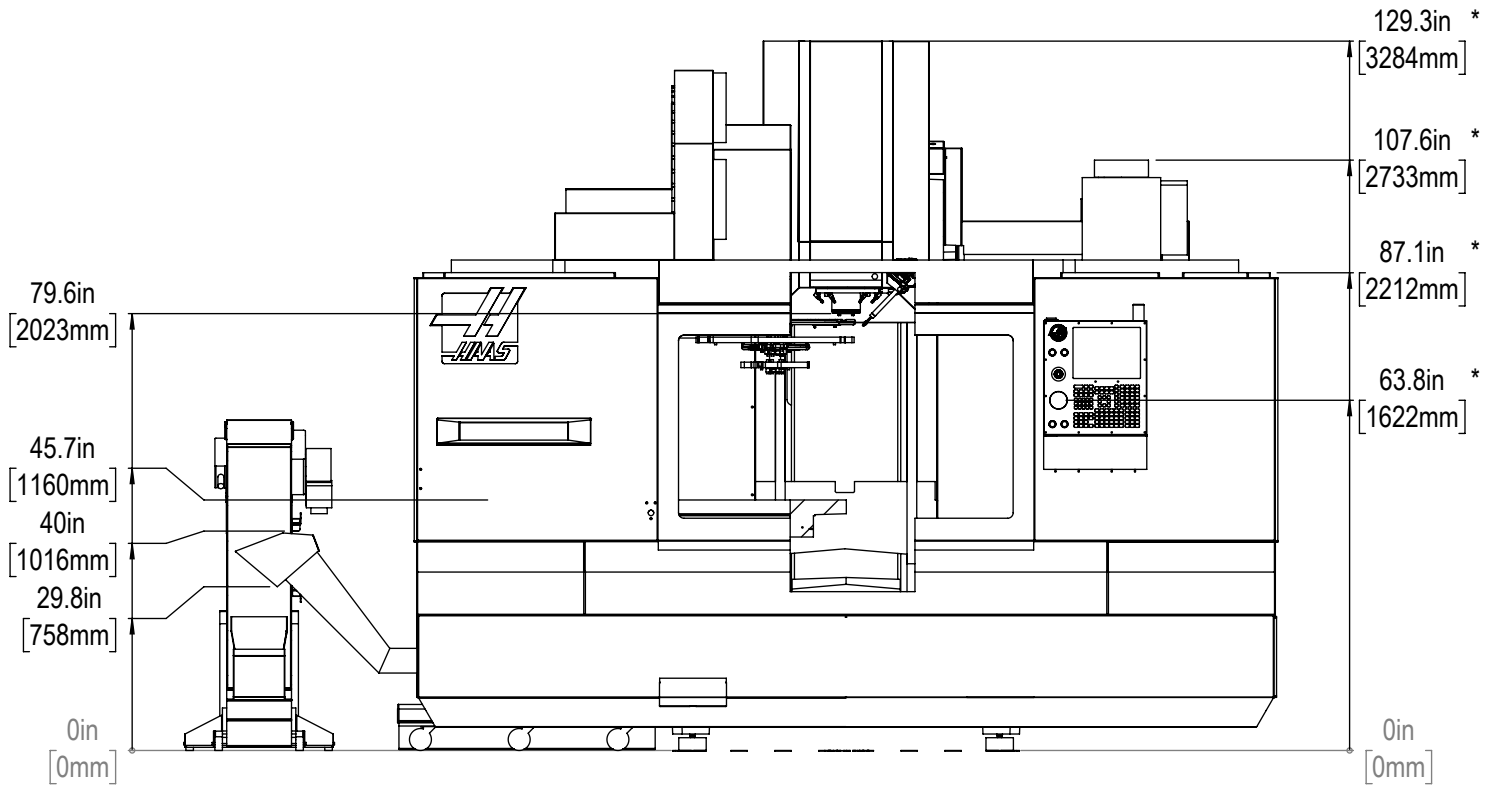

Width Breakdown

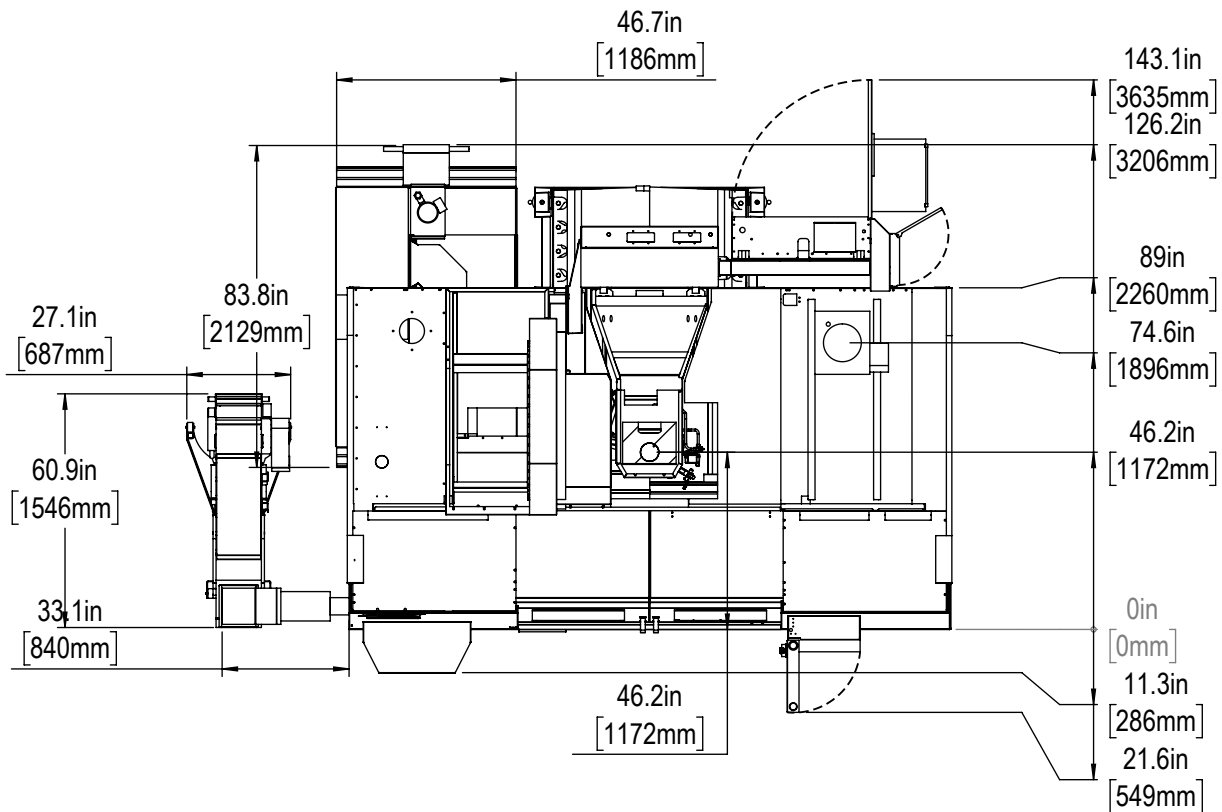

X&Y-Axis Travel and Clearance

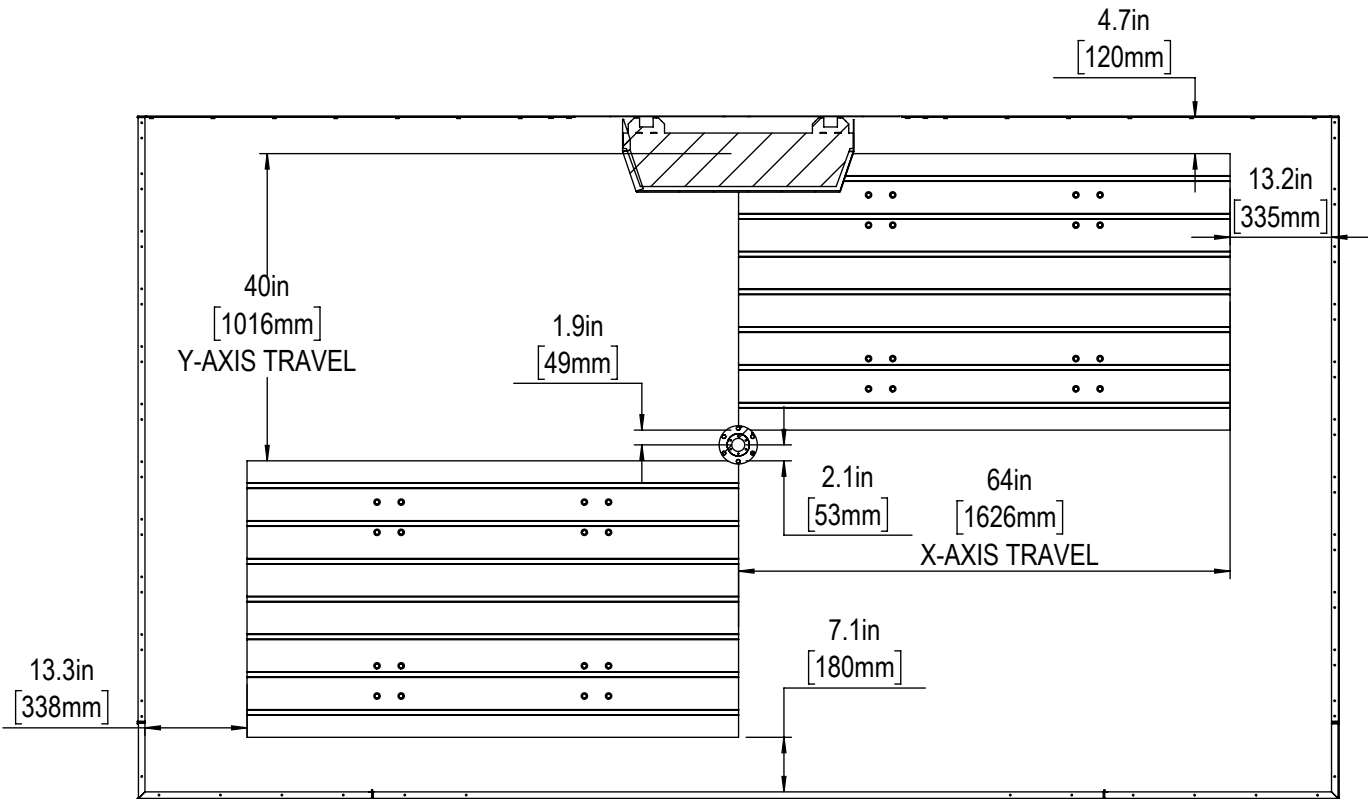

Z-AXIS TRAVEL & CLEARANCE

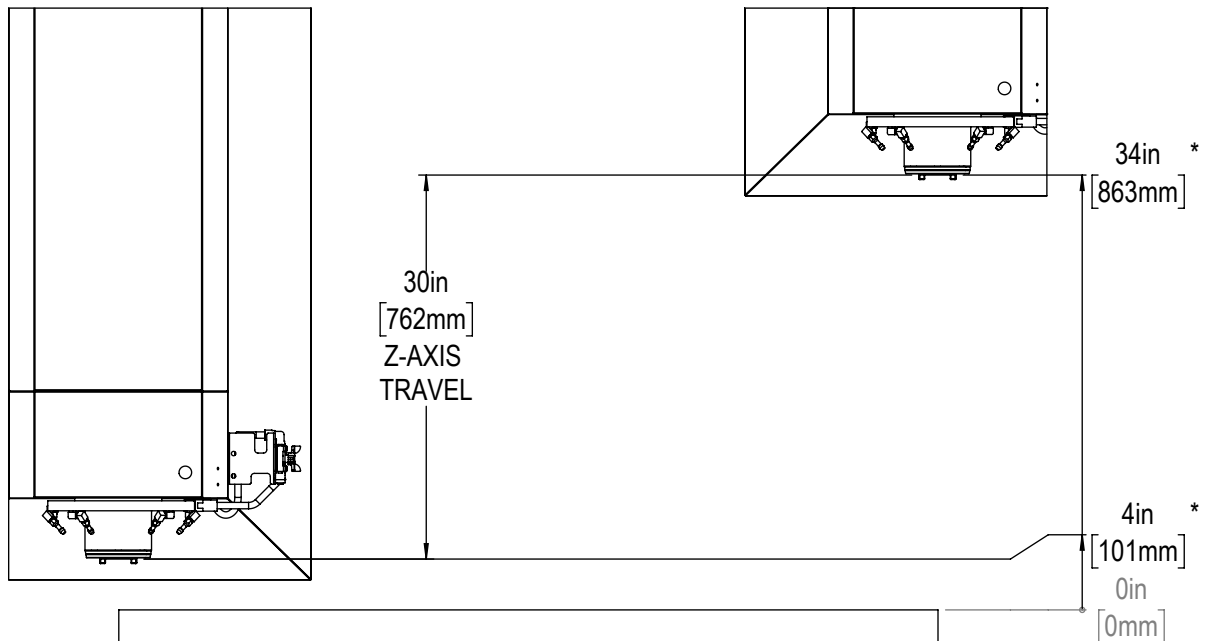

NOTE: 8" EXTENDED Z-AXIS CLEARANCE OPTION
ADDS 8" (203mm) TO DIMENSIONS WITH *

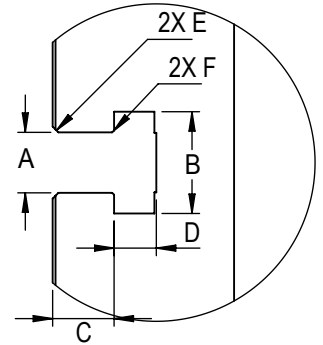
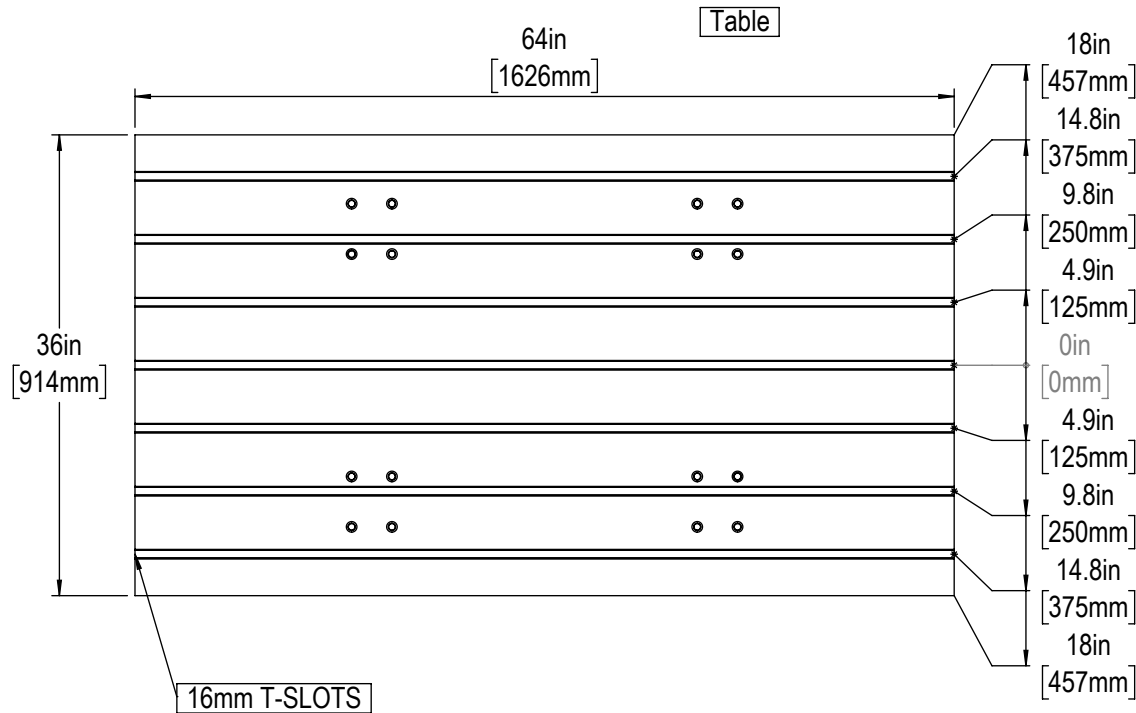

T-Slot Dimensions in inches

Slot Size	A	B	C	D	E	F
12mm	$0.438^{+0.002}_{-0.000}$	0.76 ± 0.02	0.310 ± 0.010	0.318 ± 0.010	$0.03 \times 45^\circ$	$0.020 \times 45^\circ$
16mm	0.628 ± 0.002	1.06 ± 0.02	0.640 ± 0.010	0.420 ± 0.010	$0.06 \times 45^\circ$	$0.020 \times 45^\circ$

Tool Changer

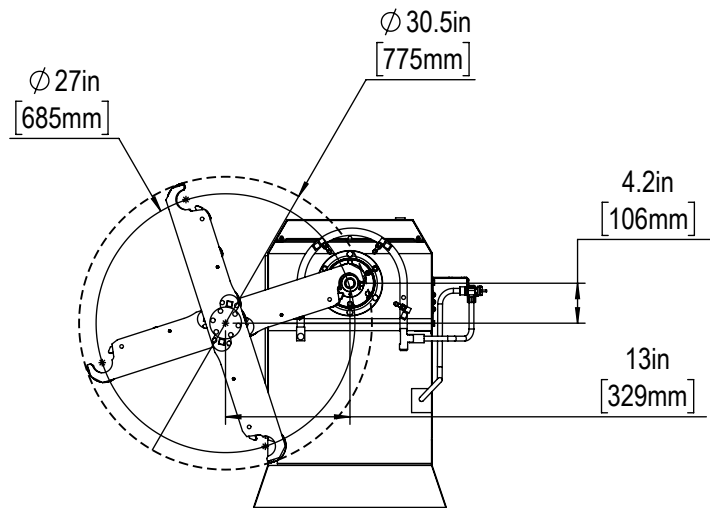
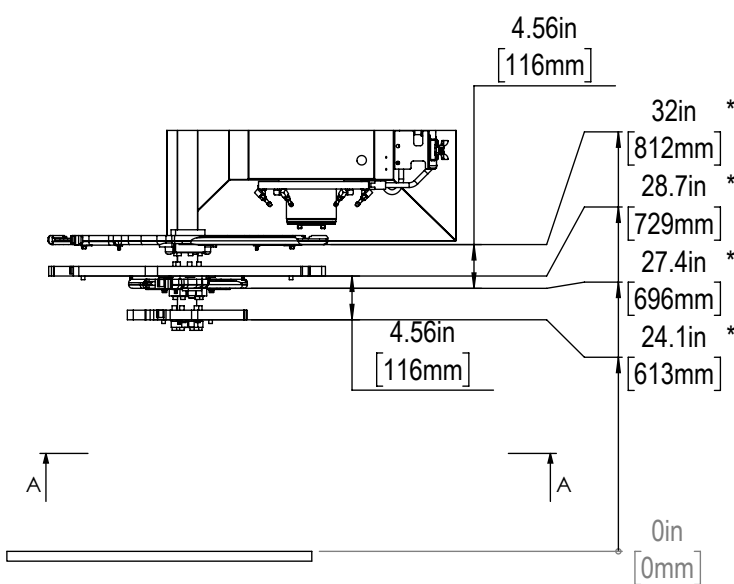

SECTION A-A