

Installed Dimensions

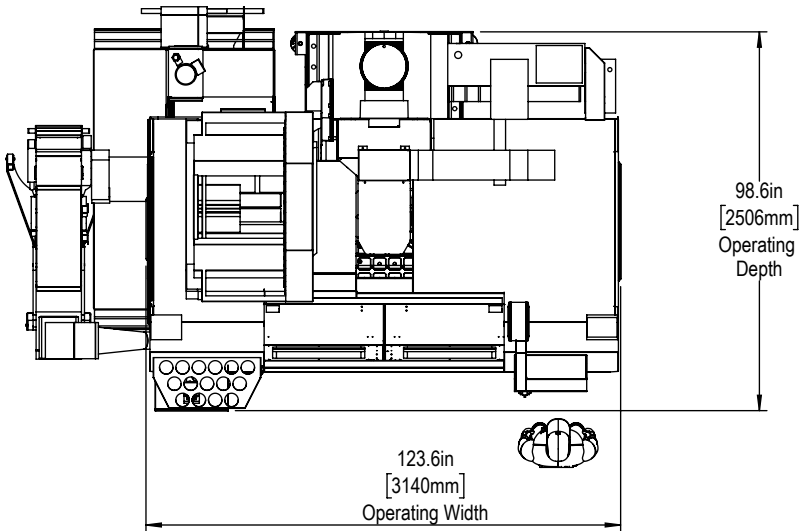

Leveling Pad Height

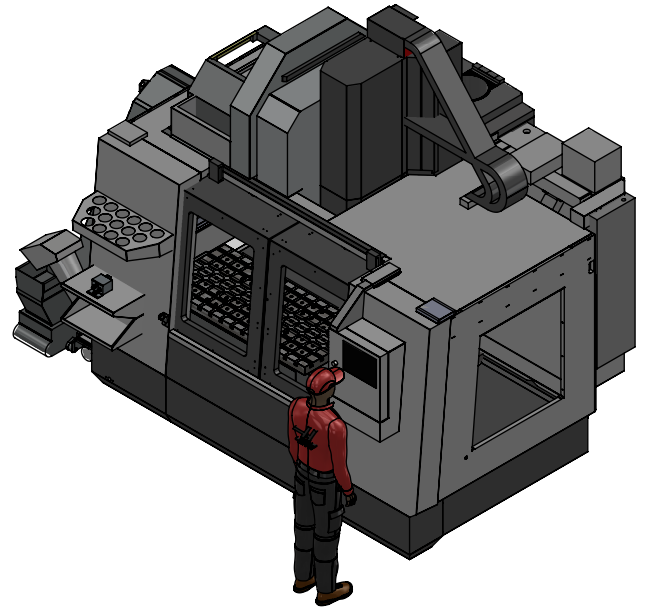
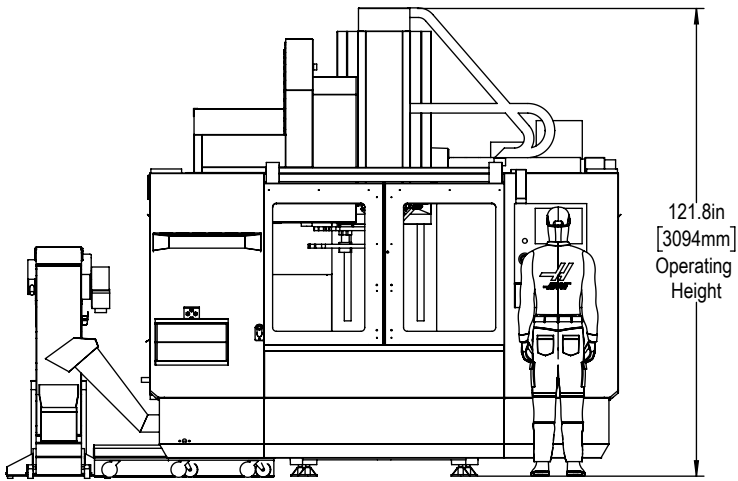
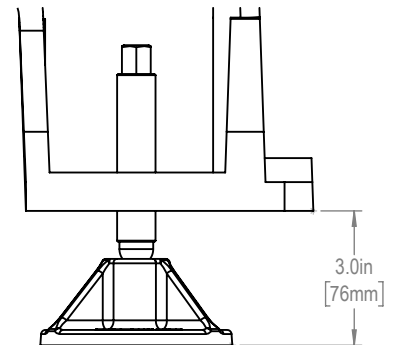

*All Height Dimensions Based on Suggested Leveling Pad Height

Shipping Dimensions

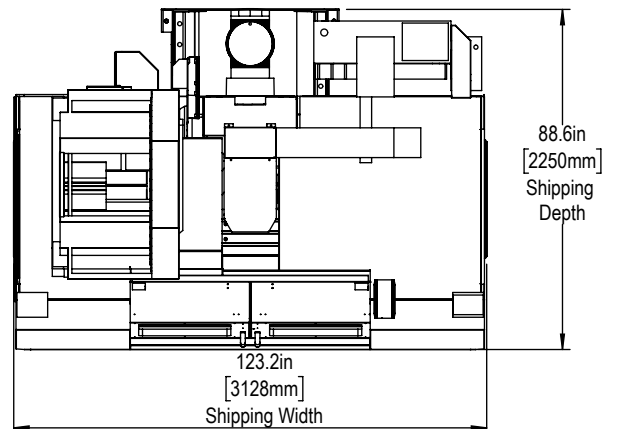
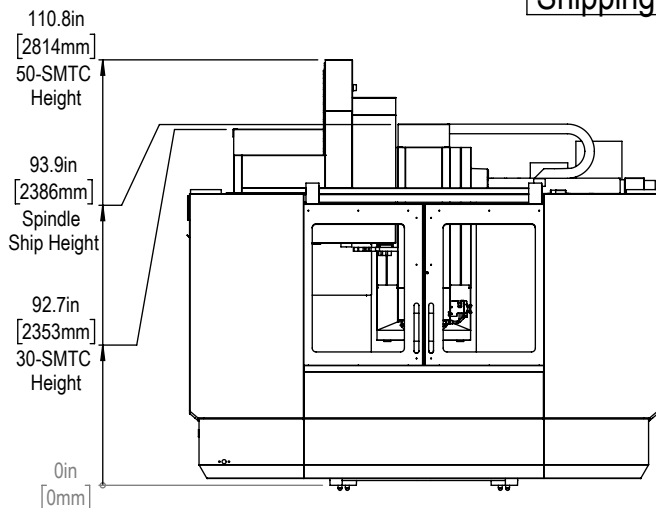

Air & Power

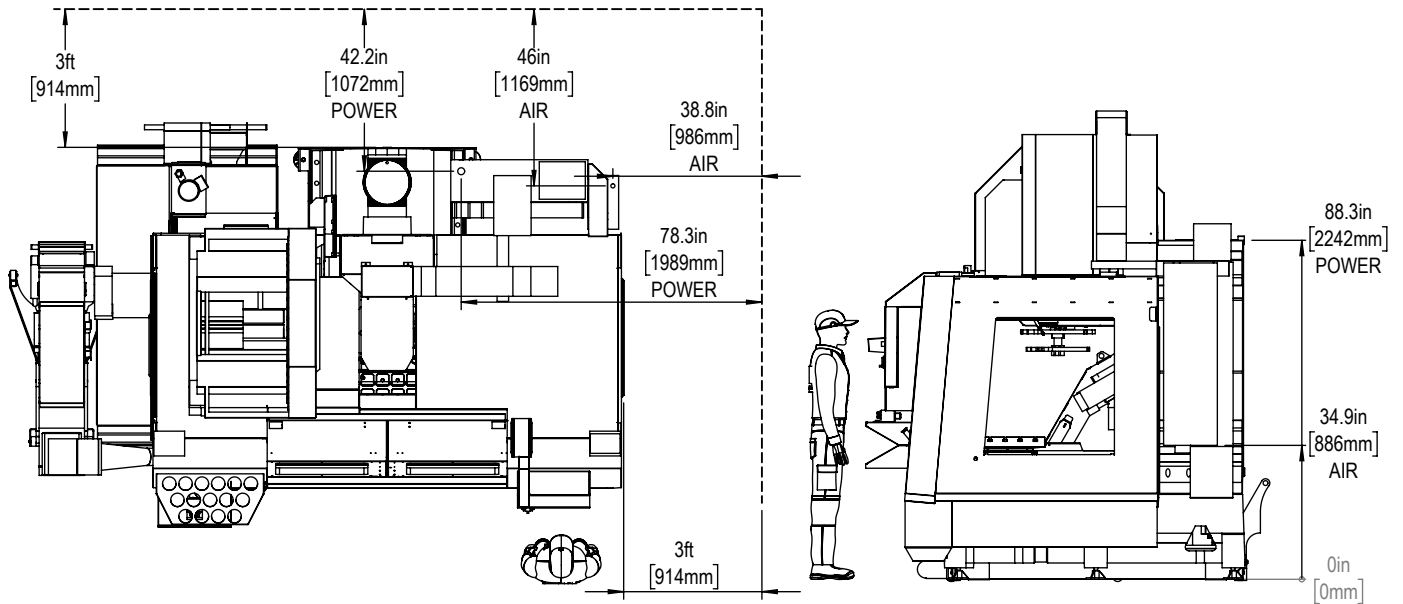

Maintain 3 feet [915mm] clearance to the nearest obstruction around all sides of machine perimeter for maintenance access

Note:
Machine must be placed on one continous concrete slab. Slab should extend 12in [305mm] beyond anchor holes in all directions

Anchor Pattern

Anchor Hole Detail
Ø0.625in
▽2.00in-2.25in

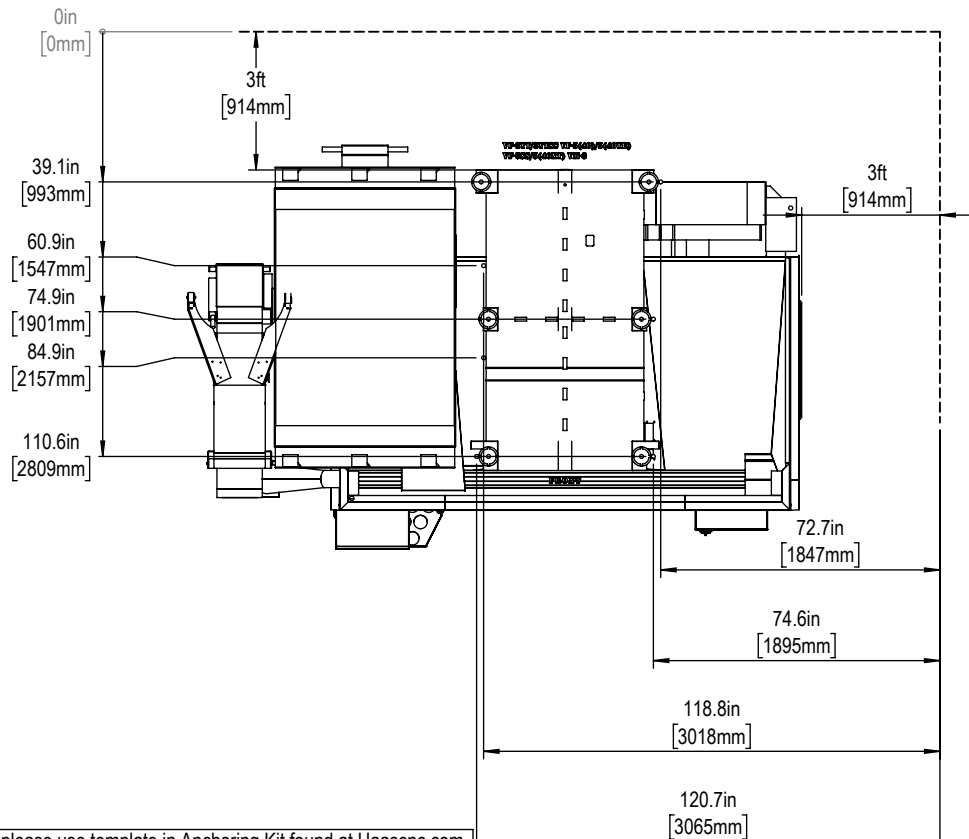

For precise locations and specifications please use template in Anchoring Kit found at Haascnc.com



Height Breakdown

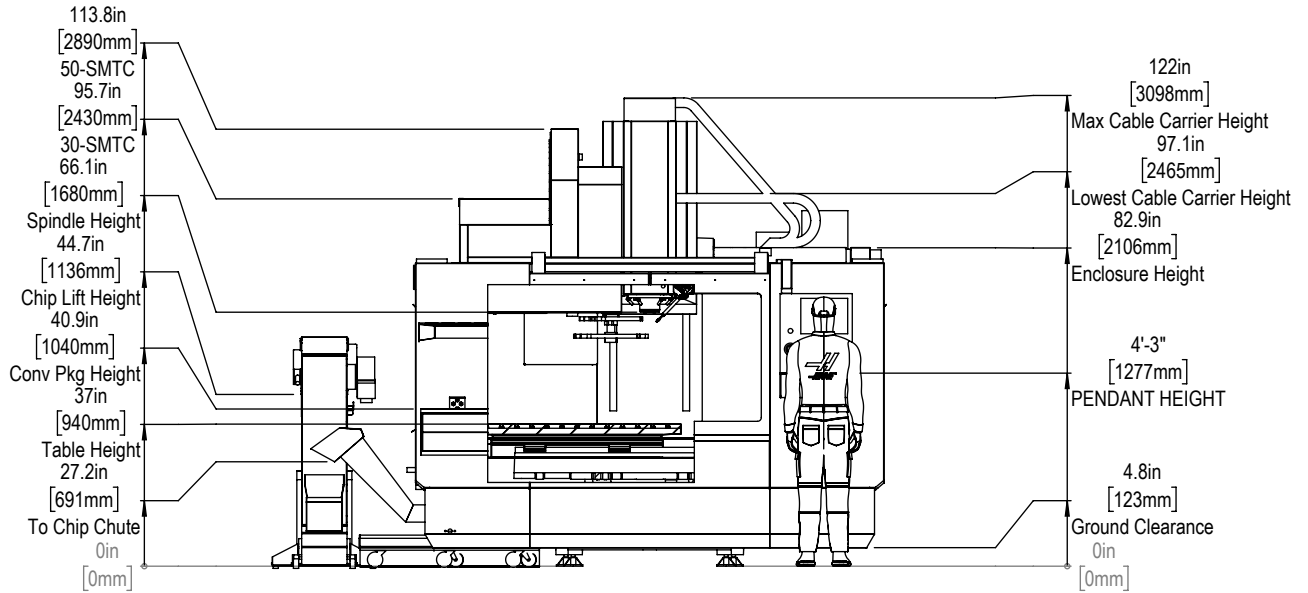

Width Breakdown

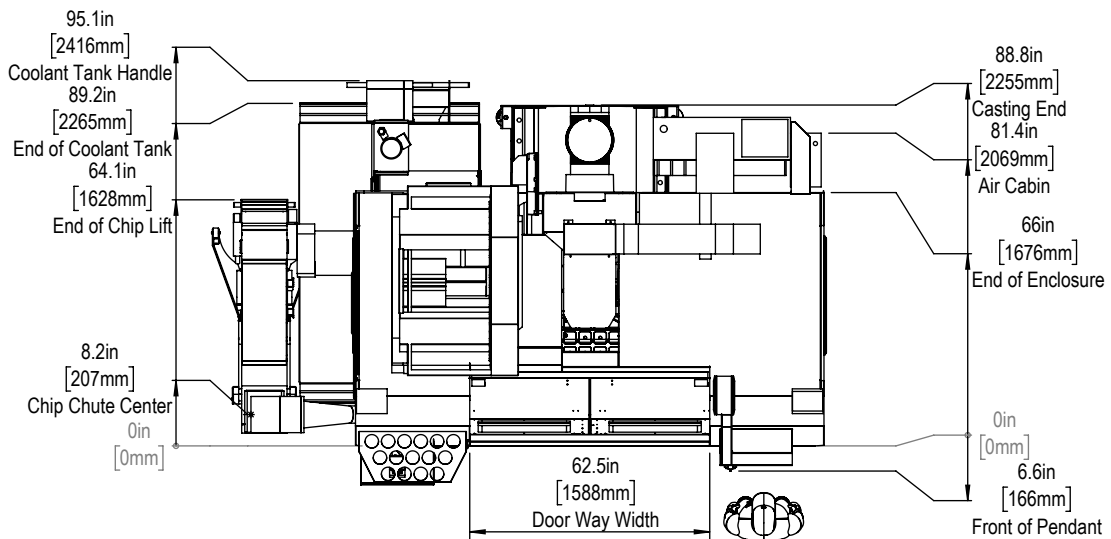

X&Y-Axis Travel and Clearance

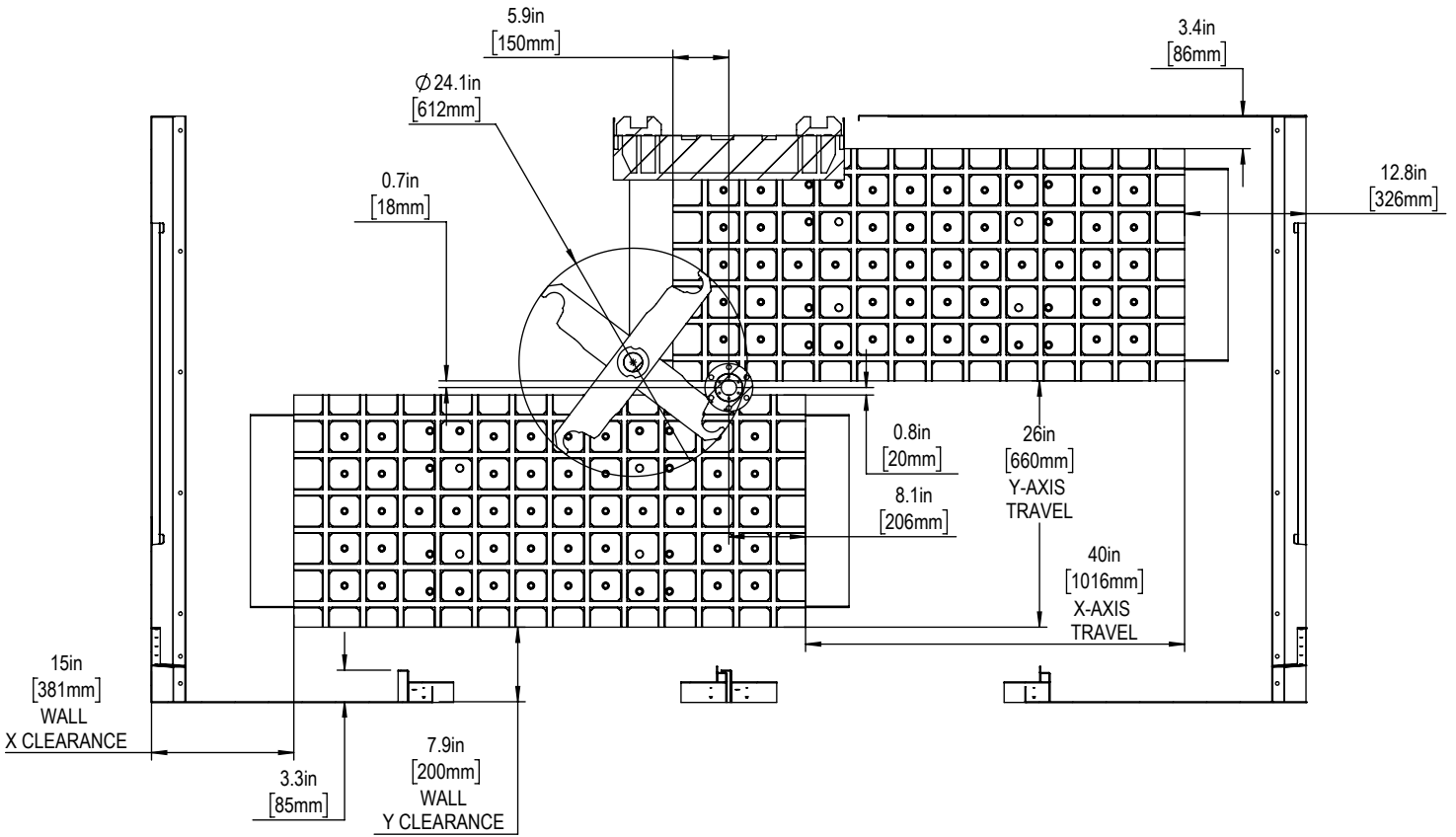

Z-Axis Travel and Clearance

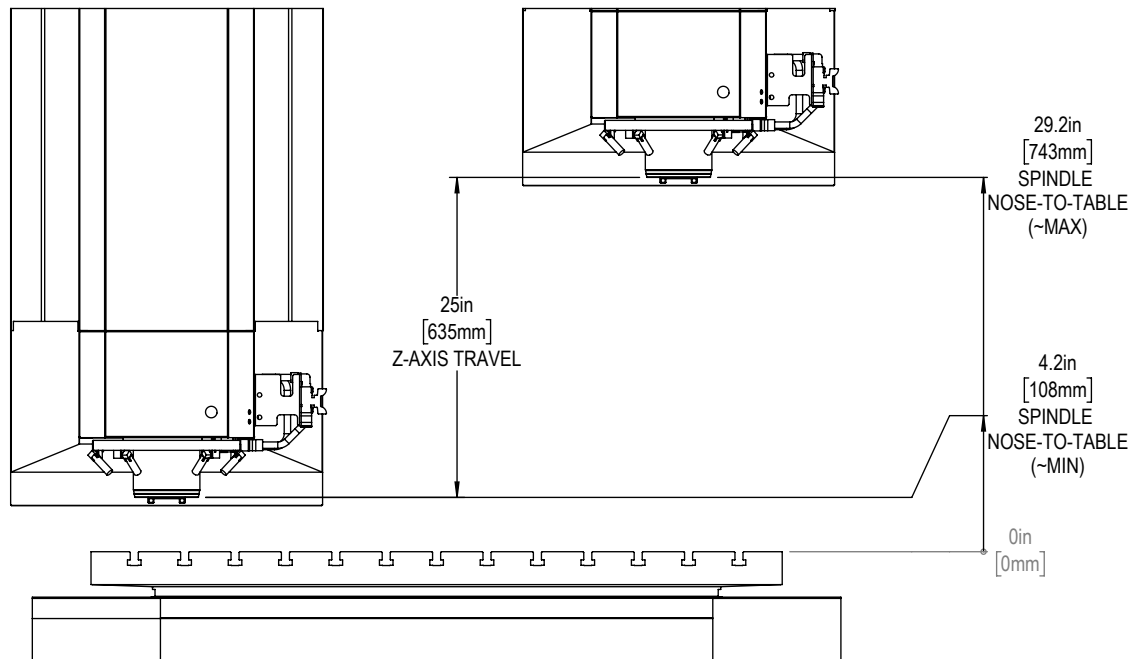



Optional Table With X T-Slot Only

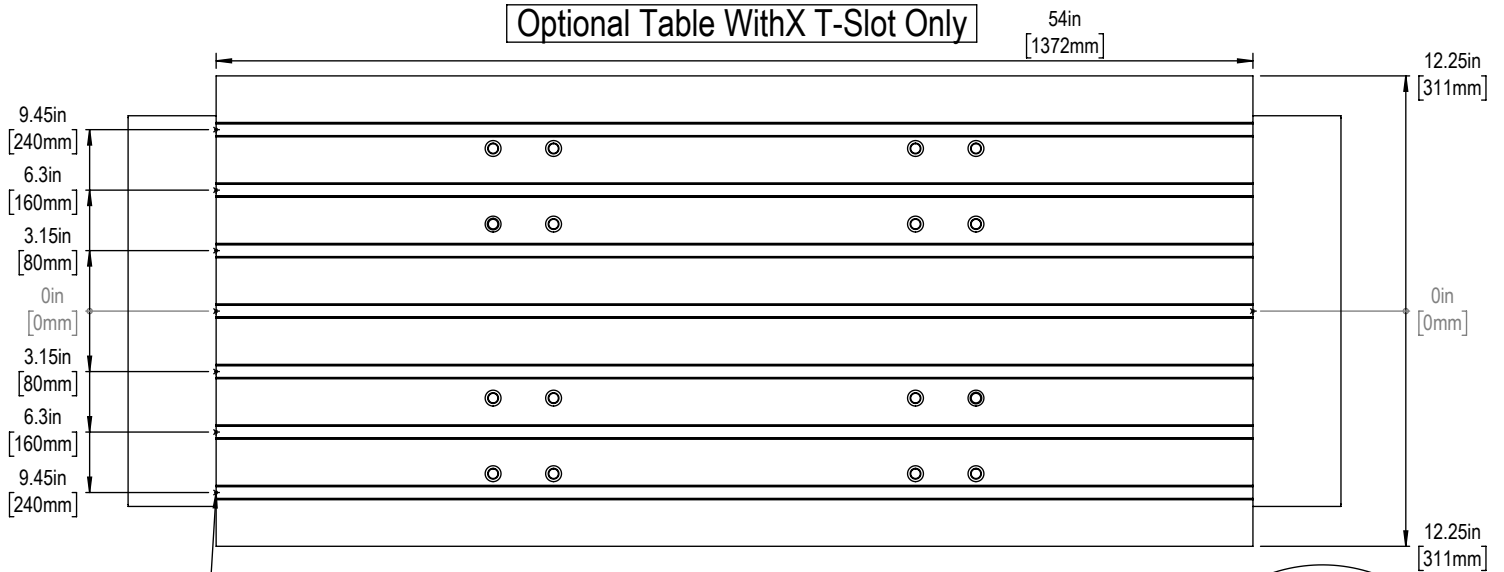

16mm T-Slots

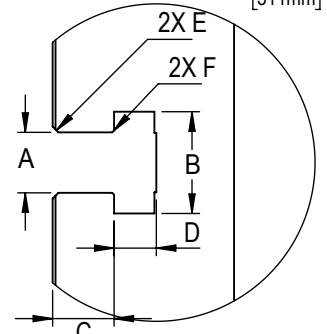

T-Slot Dimensions in inches

Slot Size	A	B	C	D	E	F
12mm	$0.438 \begin{smallmatrix} +.002 \\ -.000 \end{smallmatrix}$	0.76 ± 0.02	0.310 ± 0.010	0.318 ± 0.010	$0.03 \times 45^\circ$	$0.020 \times 45^\circ$
16mm	0.628 ± 0.002	1.06 ± 0.02	0.640 ± 0.010	0.420 ± 0.010	$0.06 \times 45^\circ$	$0.020 \times 45^\circ$

Tool Changer

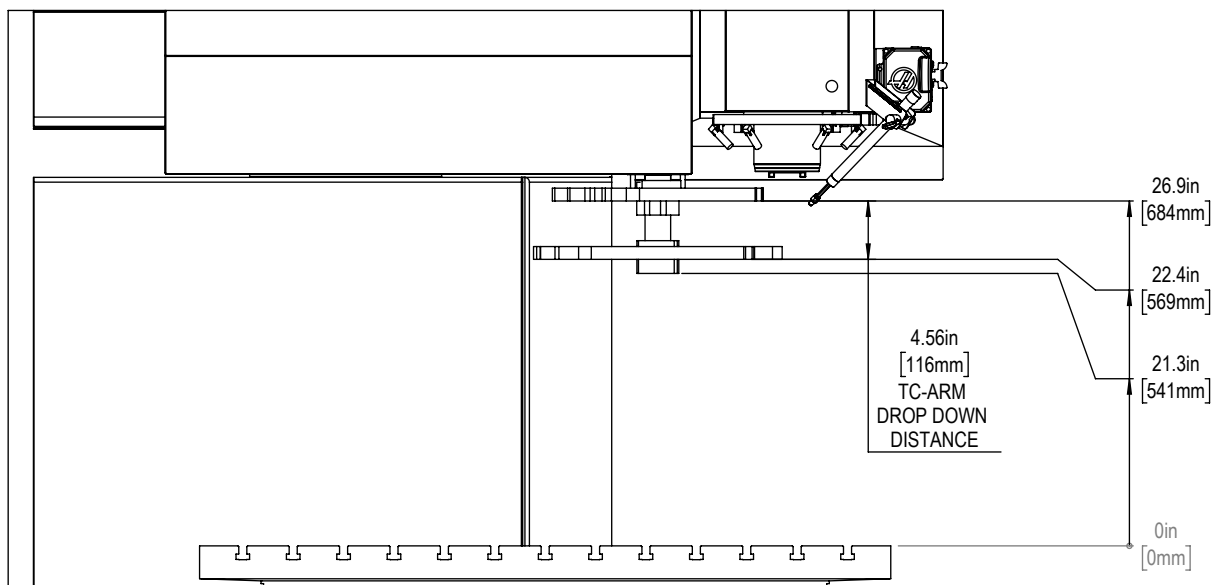



X-Y Table

