

ST-50/55 Machine Layout Drawing

- ① Electrical Connection
- ② Air Connection

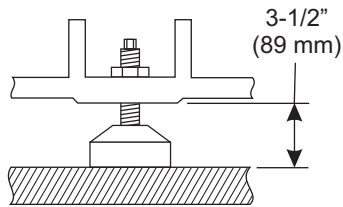

8X Leveling Pad Pin Dimension

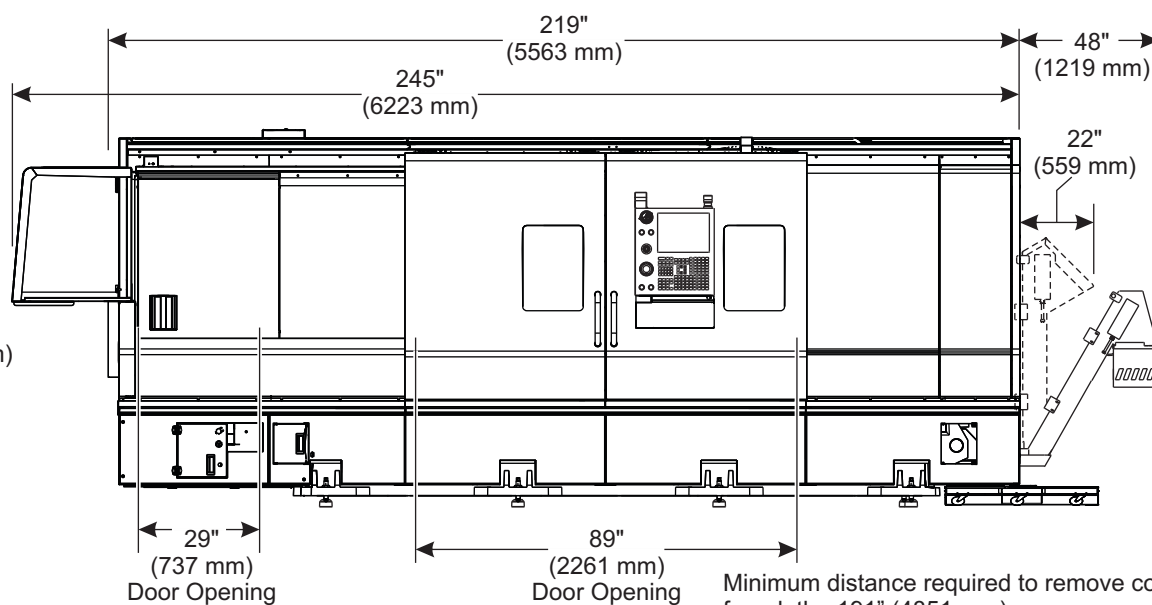
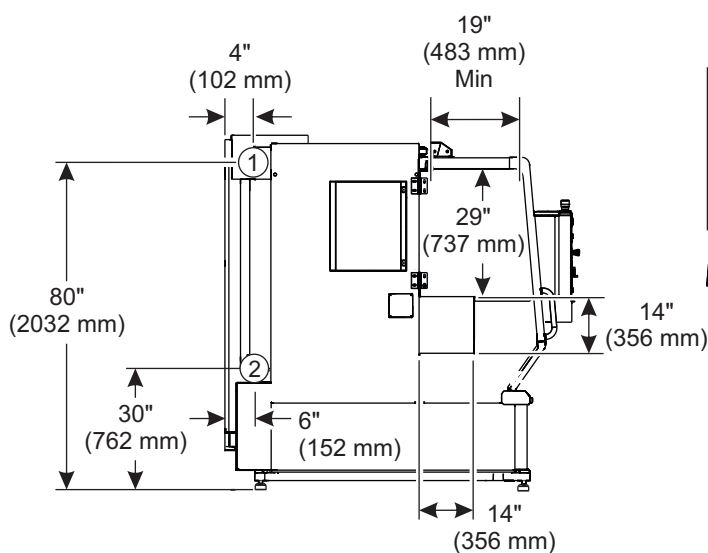
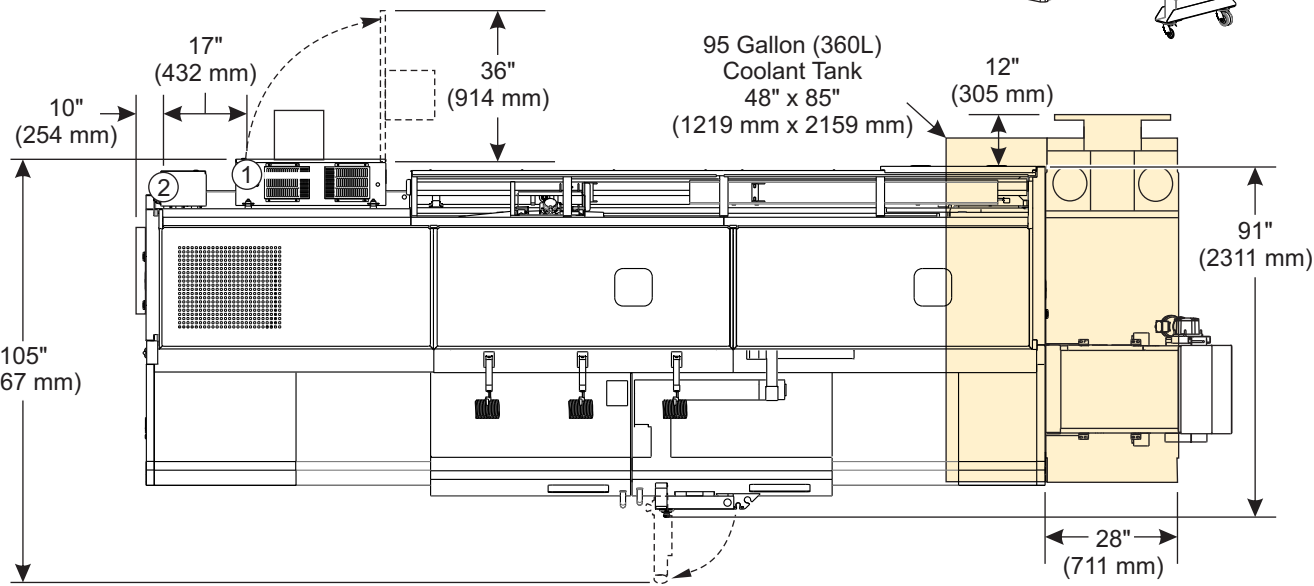
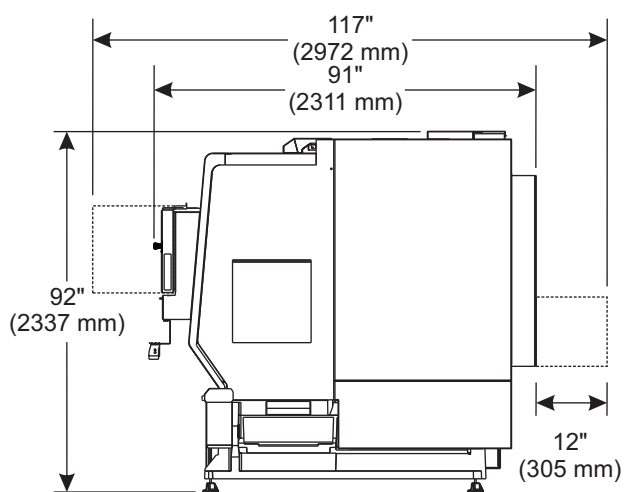
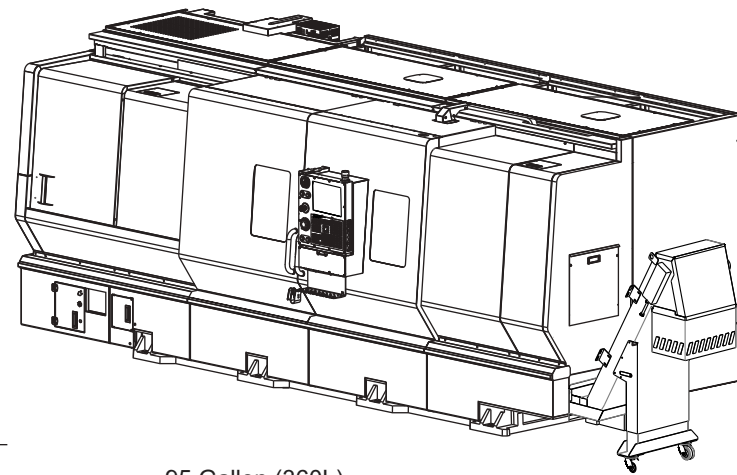

Minimum distance required to remove conveyor from lathe 191" (4851 mm).

Minimum distance required to remove conveyor from lathe 145" (3683 mm) when conveyor is folded at 90 degrees and folded down as it is pulled out.

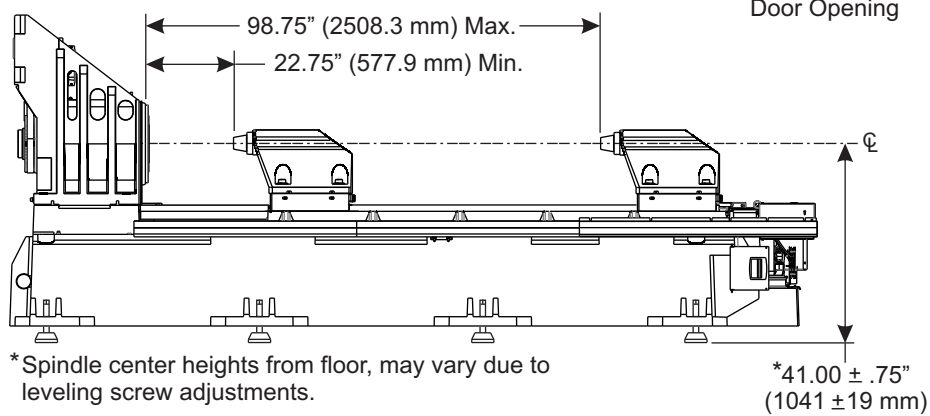

*41.00 ± .75" (1041 ± 19 mm)

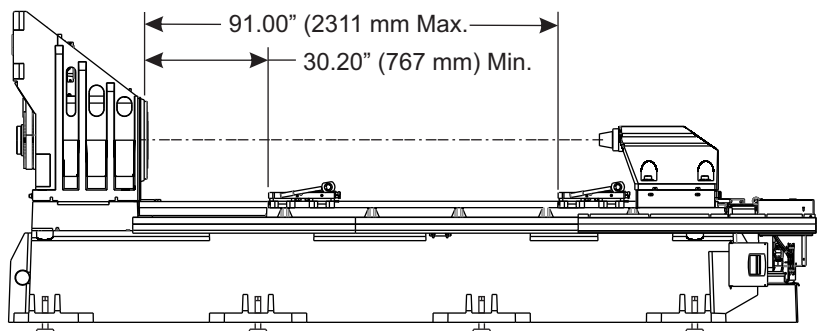

ST-50/55 Tailstock and Steady Rest Travel #6 Morse Taper

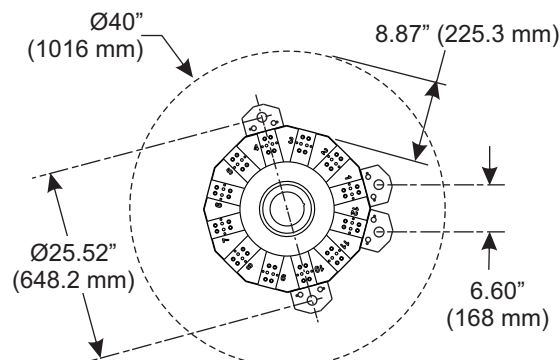

12-Station BOT Turret Standard
ST-50/55 Tool Interference

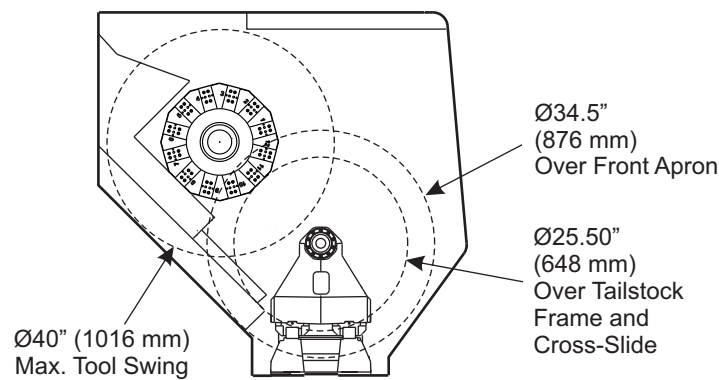

ST-50/55 Tool Swing Envelope
Turret at Home Position
12-Station BOT Turret Standard

ST-50/55 Revision A
Page 1 of 2
Nov, 2014

ST-50/55 Machine Layout Drawing

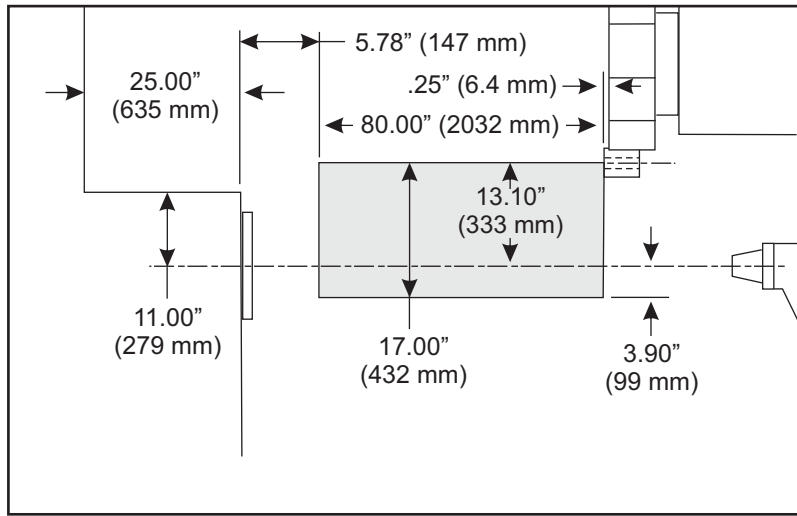
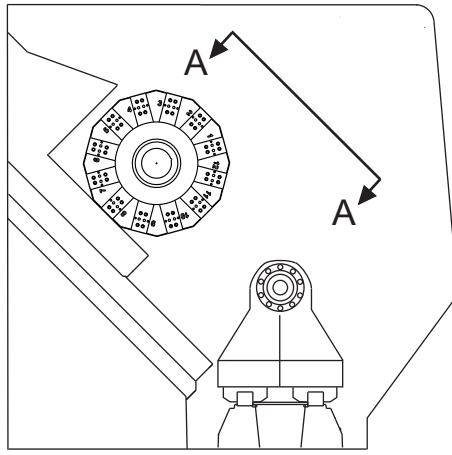

BOT ID

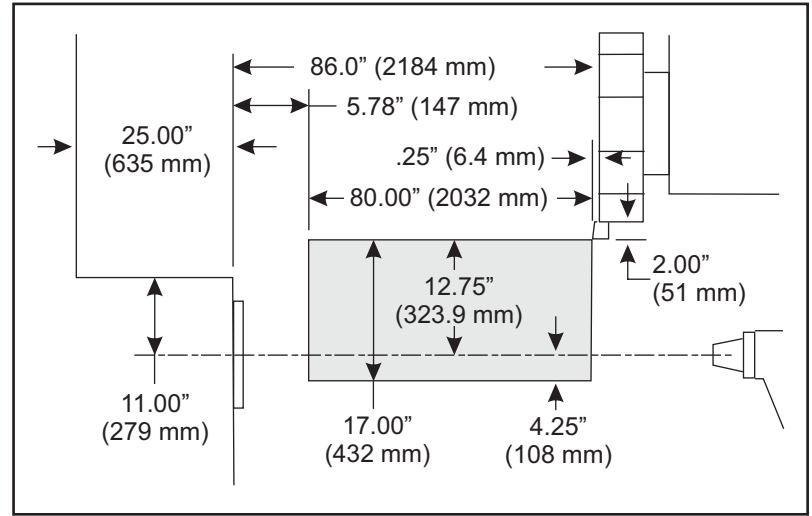

BOT OD

View A-A ST-50/55 Cut Envelope Diagrams

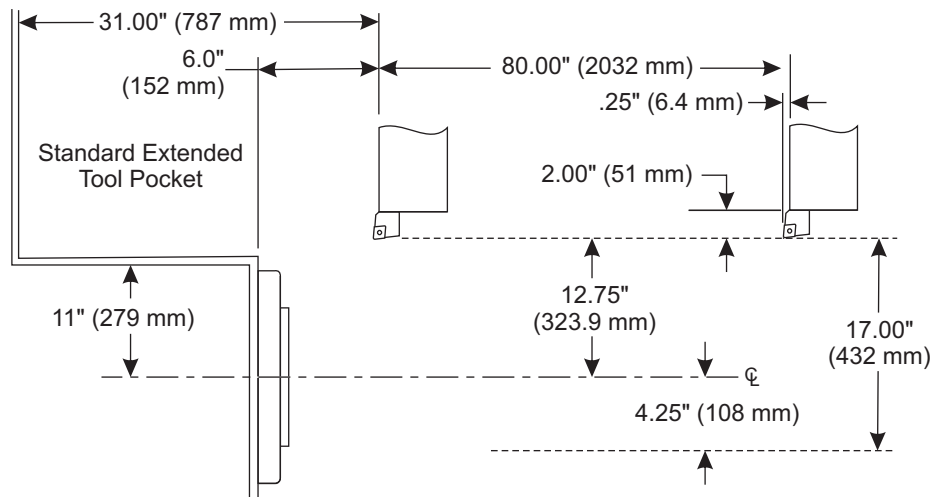

Axis Travels - ST-50/55 with Standard BOT

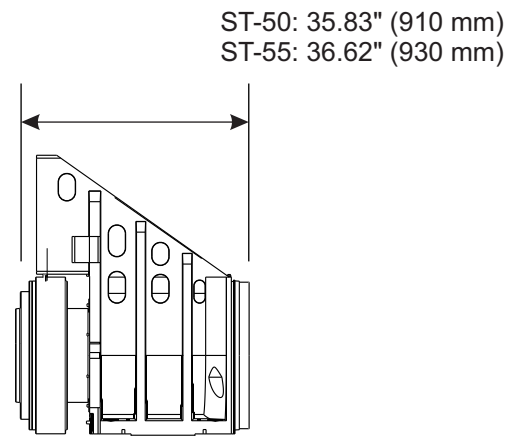

ST-50/55 Distance Between Spindles

ST-50: 35.83" (910 mm)
ST-55: 36.62" (930 mm)

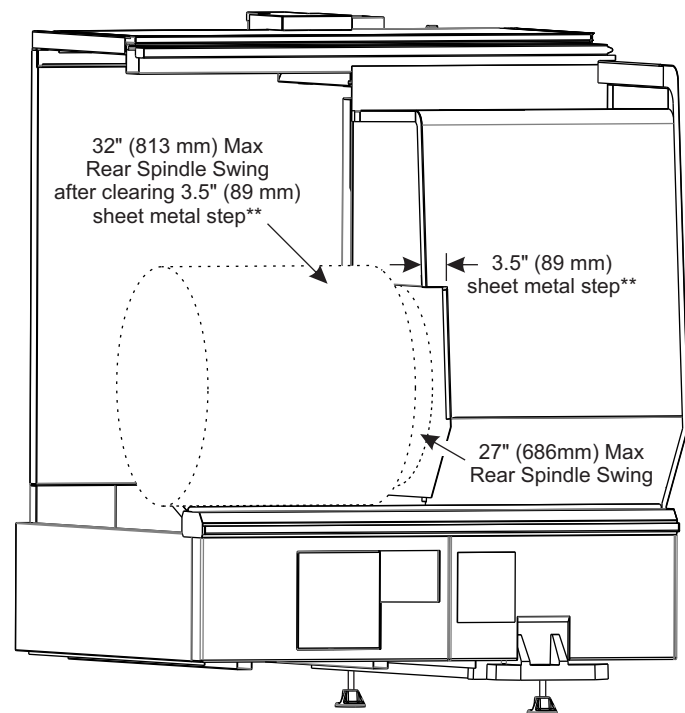
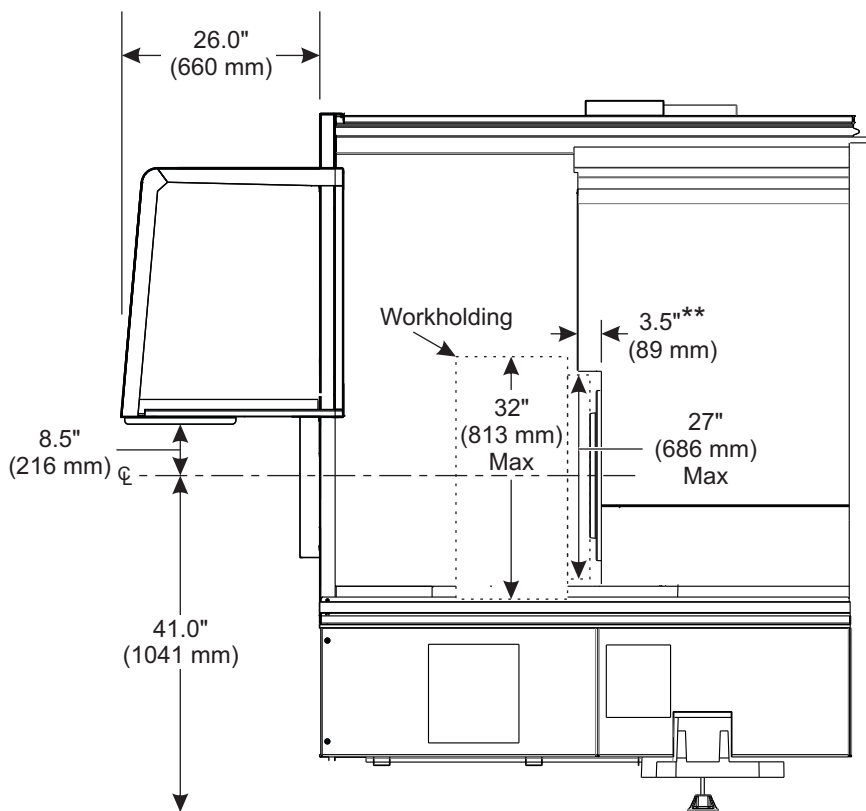

Rear Spindle Swing
(Sheet metal removed for clarity)

ST-50/55 Revision A
Page 2 of 2
Nov, 2014