

GR-712 Anchor Pattern

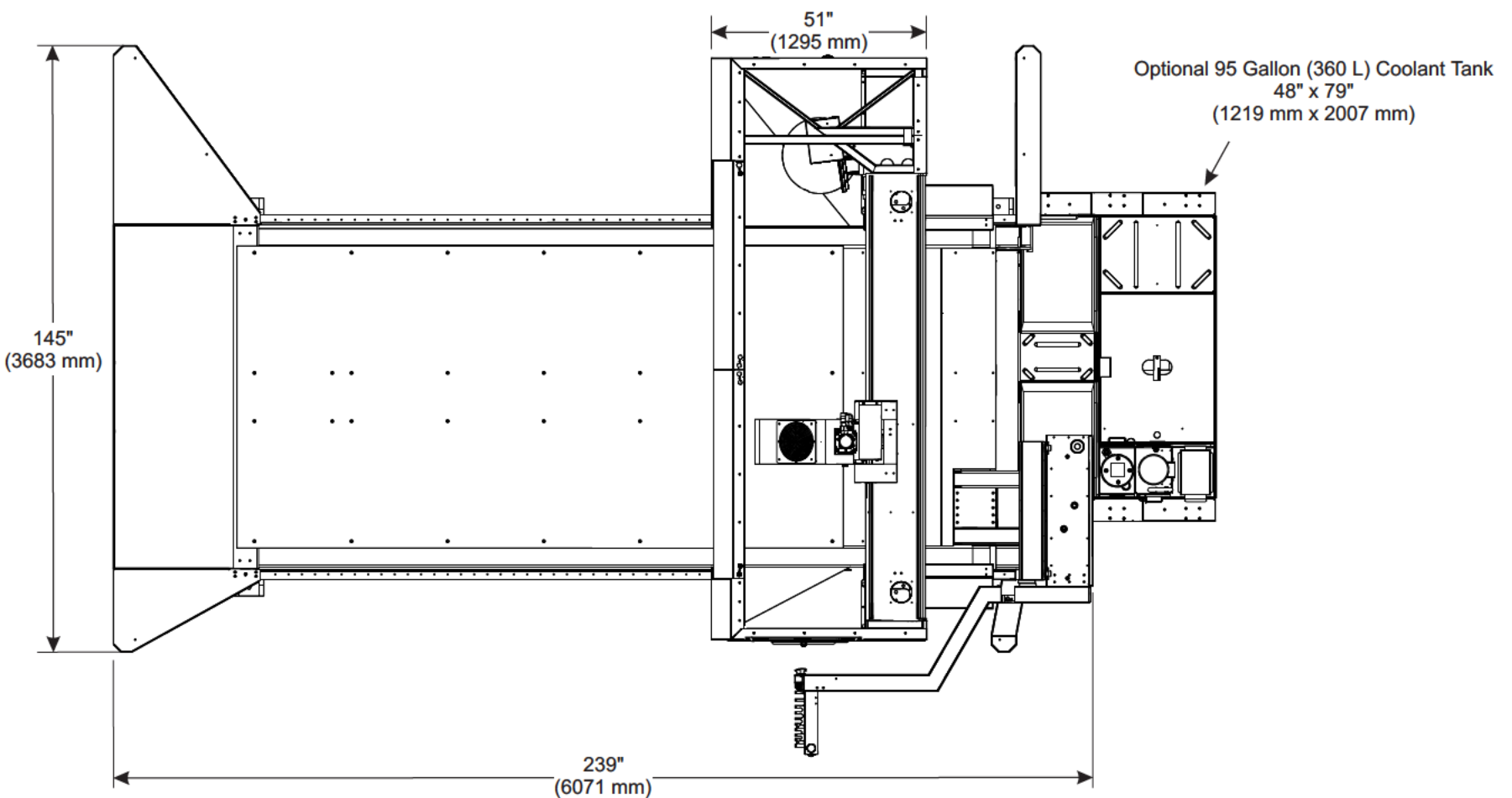

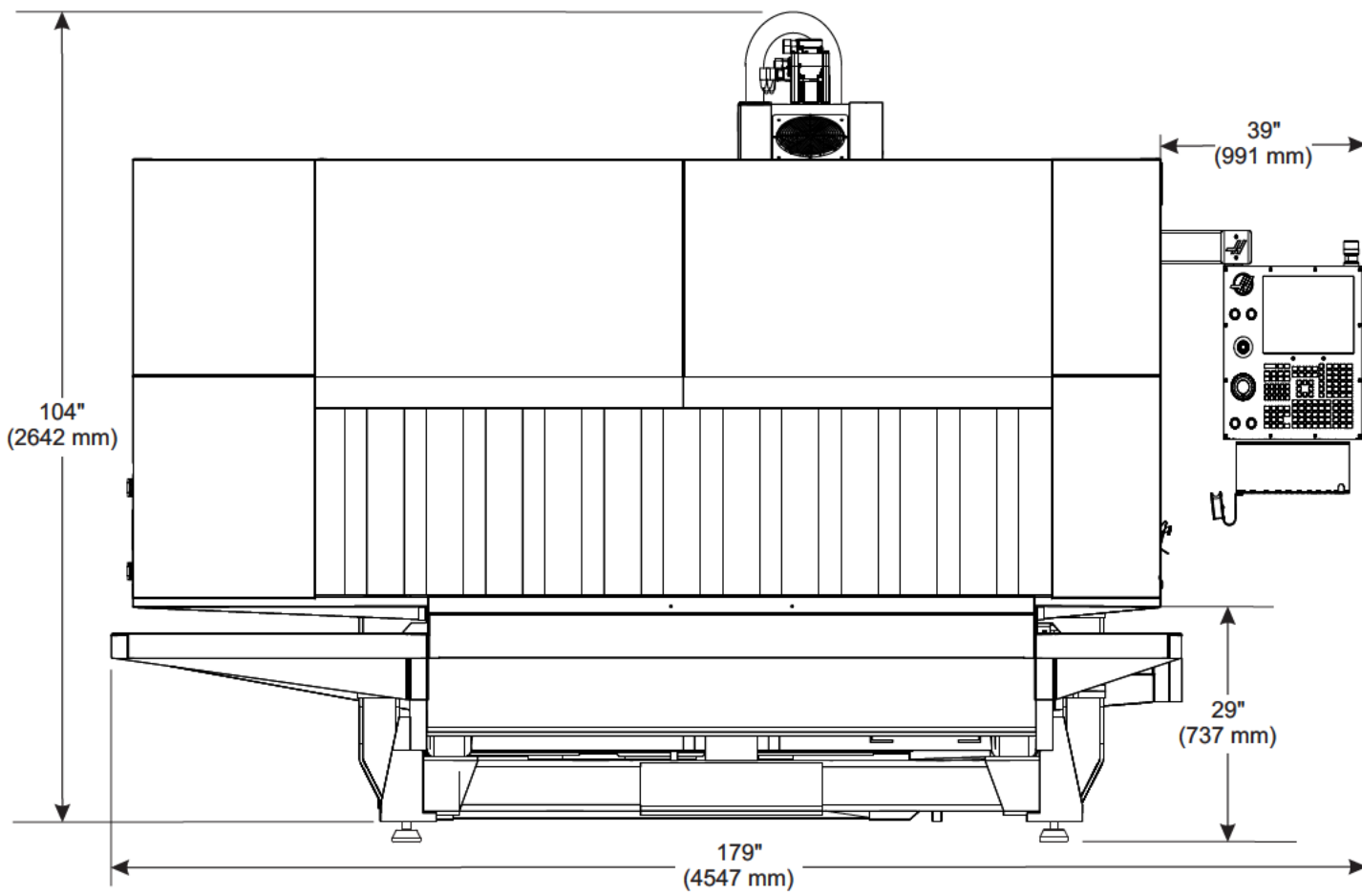
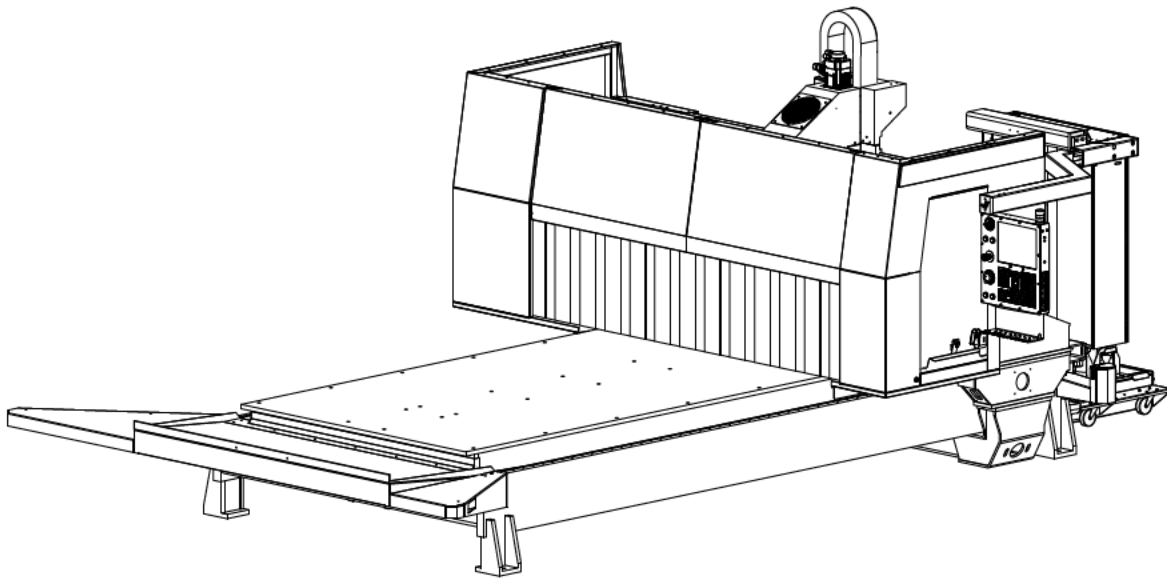
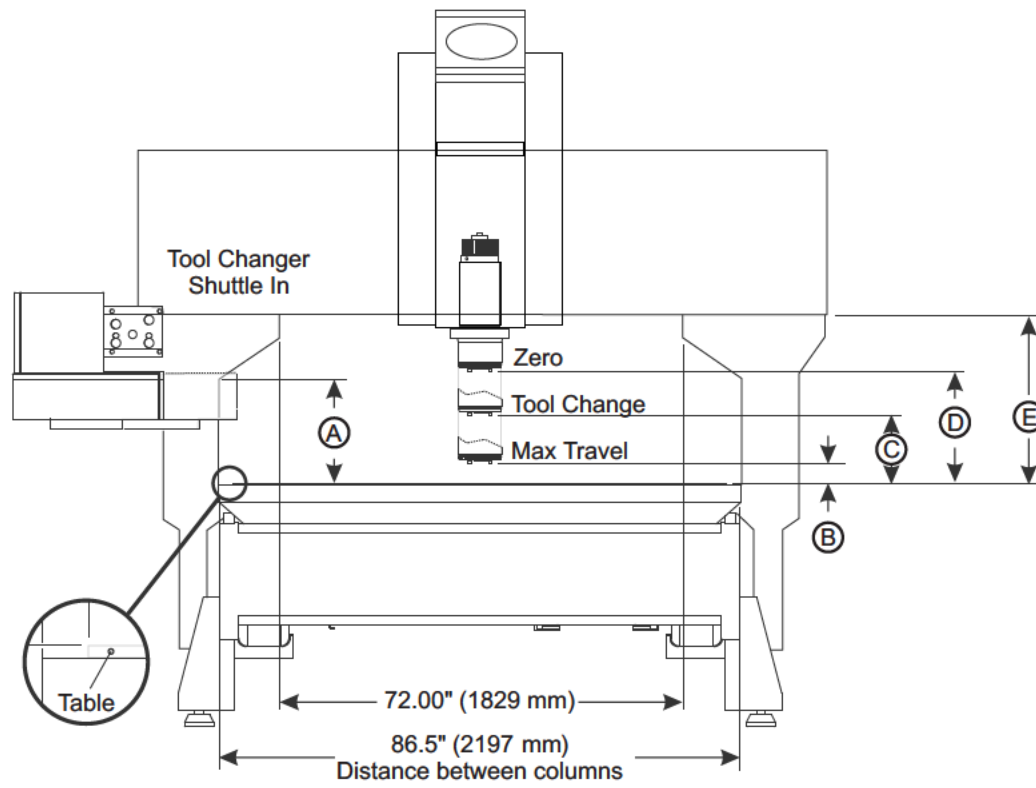
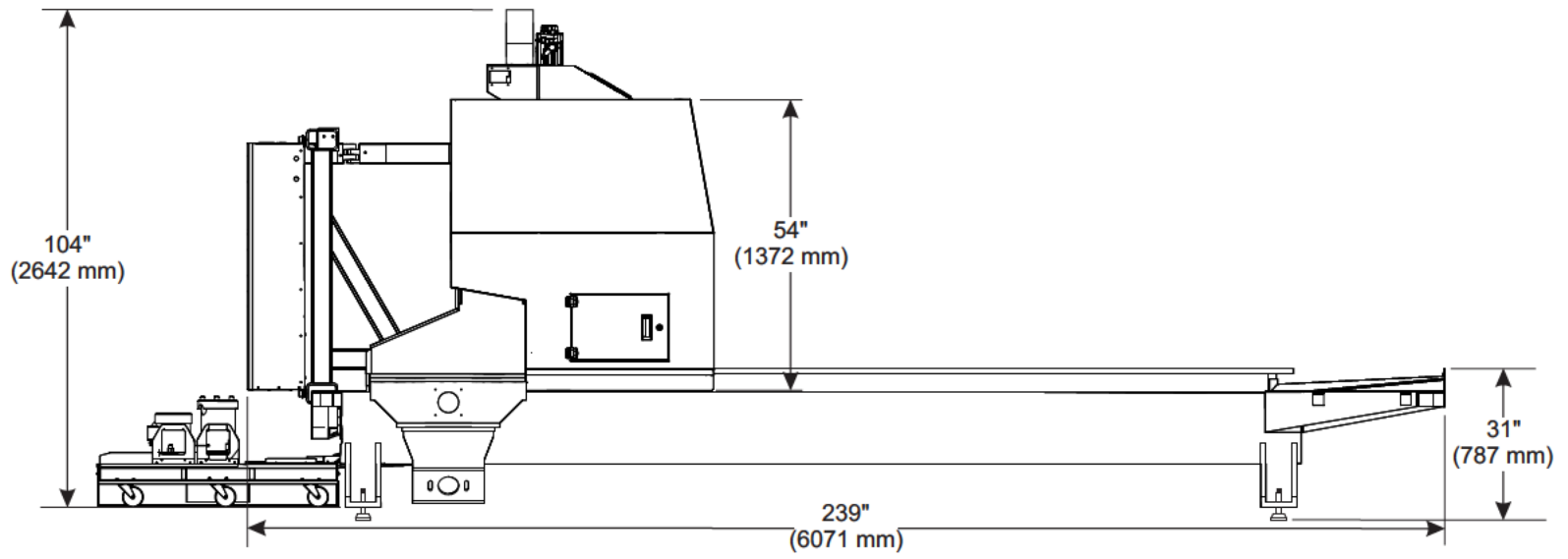
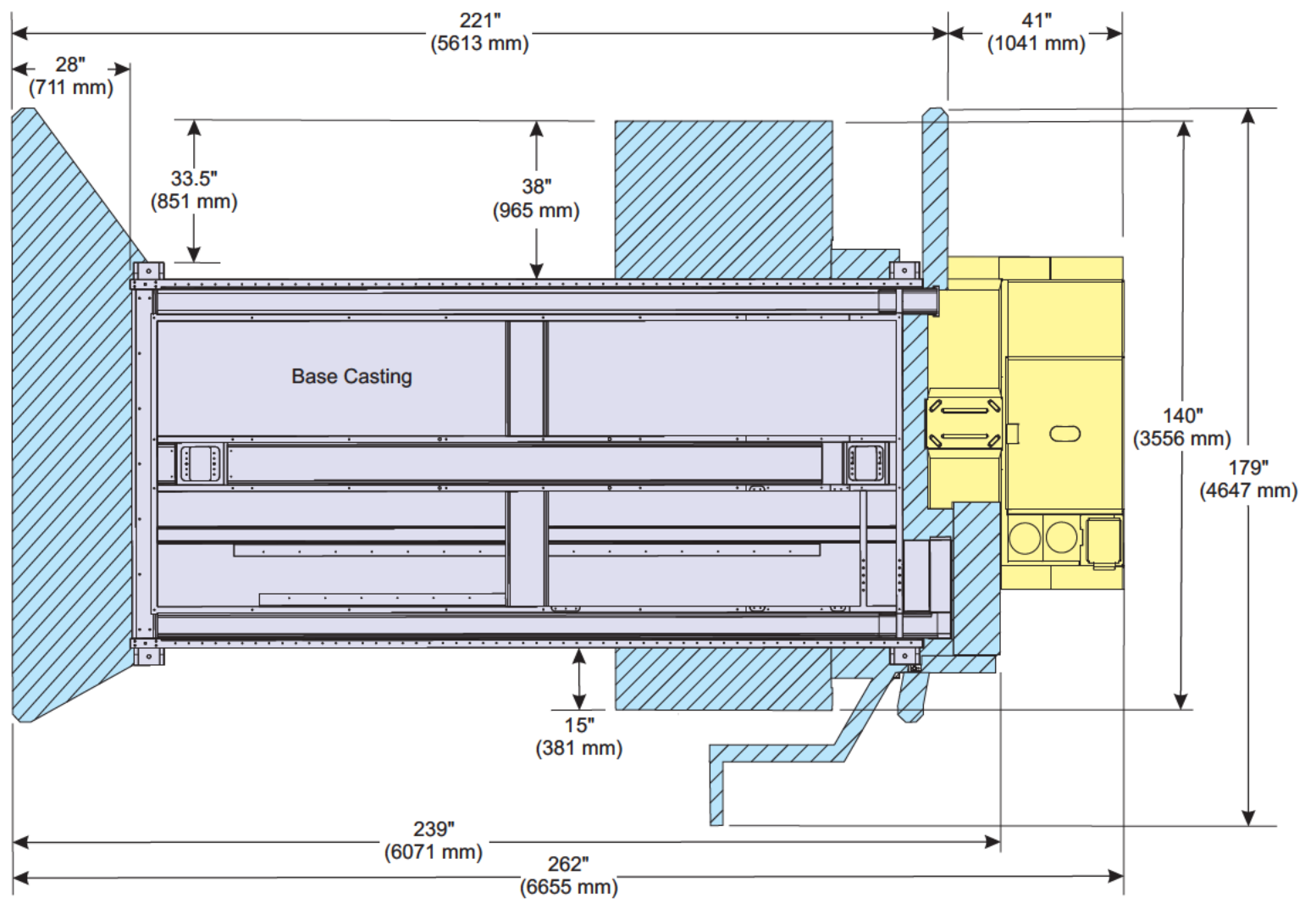

GR-712 Work Space

	Standard	6" Extended Z-Axis Clearance	24" Extended Z-Axis Travel
(A)	13.00" (330 mm)	19.00" (483 mm)	27.50" (699 mm)
(B)	2.50" (64 mm)	8.50" (216 mm)	4.00" (102 mm)
(C)	8.25" (210 mm)	14.25" (362 mm)	23.50" (597 mm)
(D)	13.50" (343 mm)	19.50" (495 mm)	28.00" (711 mm)
(E)	20.50" (521 mm)	26.50" (673 mm)	35.00" (889 mm)

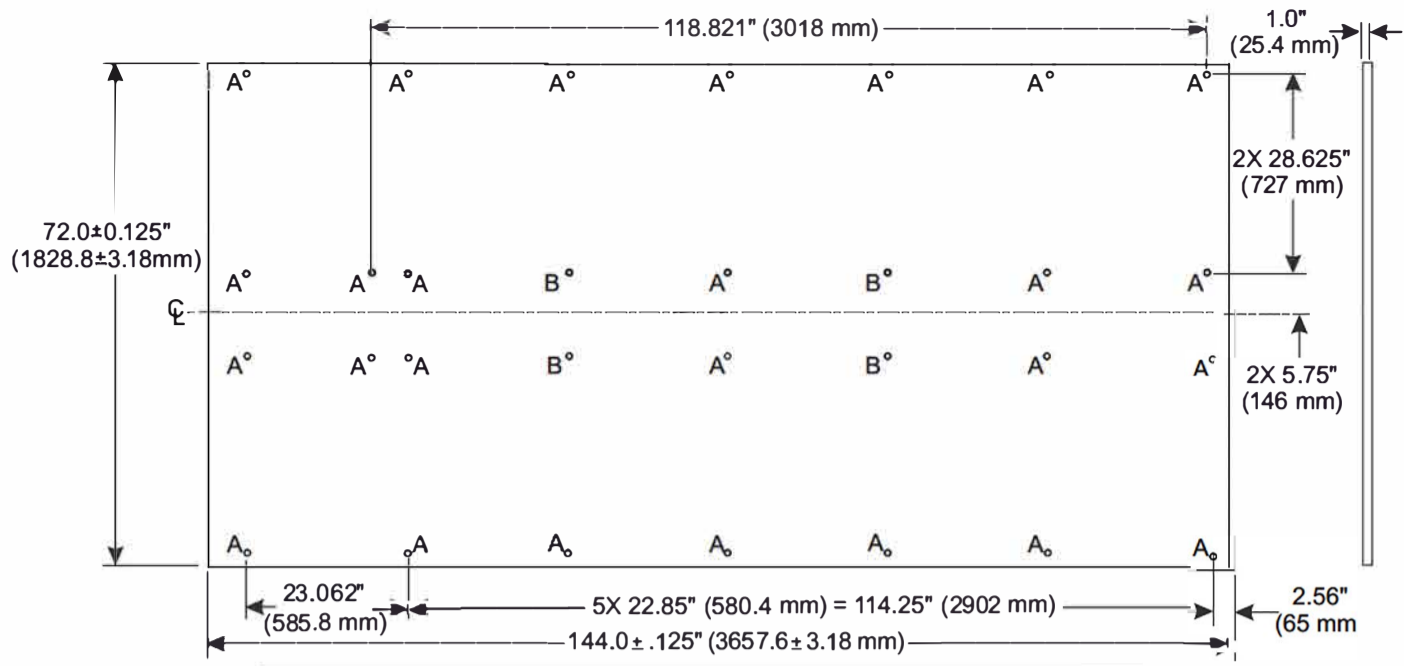

Aluminum Table Hole Dimensions		QTY.
A	Ø.391" (9.93 mm) Thru x C'Sink Ø.709" (18 mm) x 0.59" (15 mm) Deep	26
B	1/2-13 UNC-2B Thru x C'Sink Ø.709" (18 mm) x 0.59" (15 mm) Deep	4

GR-712 Aluminum Table

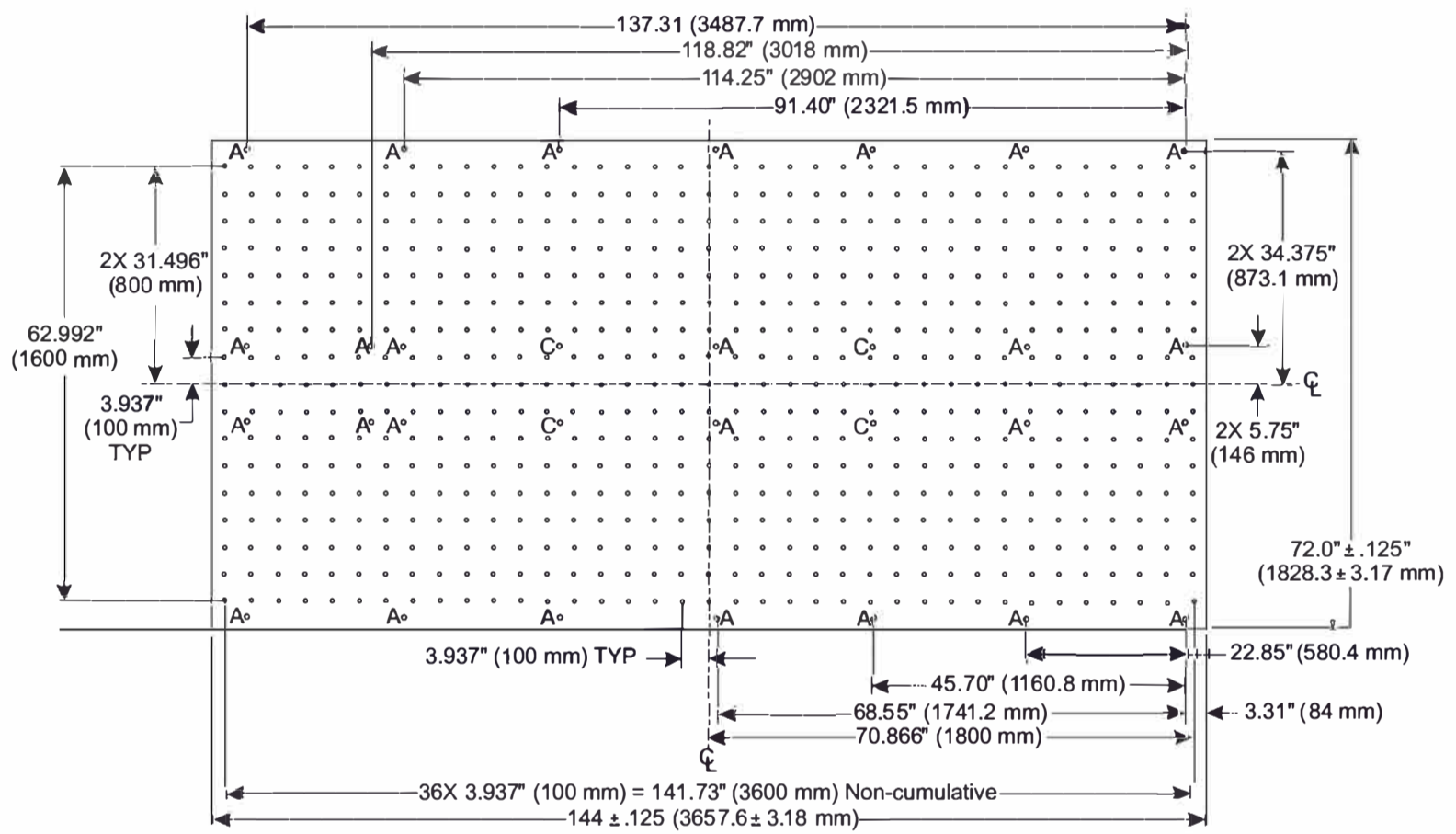

Steel Table Hole Dimensions		QTY.
A	Ø.391" (9.93 mm) Thru x C'Bore Ø.709" (18 mm) x 0.59" (15 mm) Deep	26
B	1/2-13 UNC-2B Thru x C'Bore Ø.709" (18 mm) x 0.59" (15 mm) Deep	4
	* All unmarked holes - M12 x 1.75" (44.45 mm) x 0.75" (19 mm) Deep	629

* Do Not Drill Thru

GR-712 Steel Table