

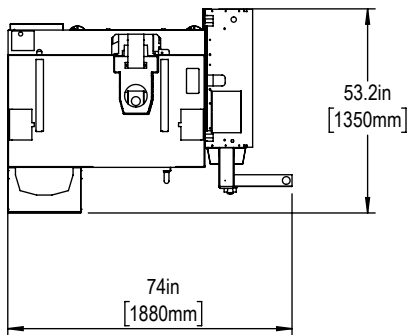

Installed Dimensions

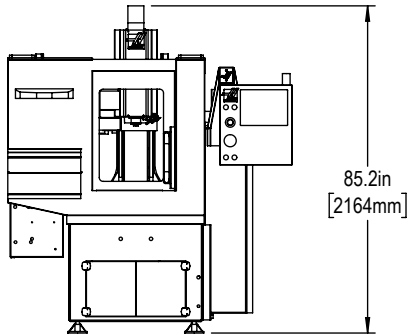

Leveling Pad Height

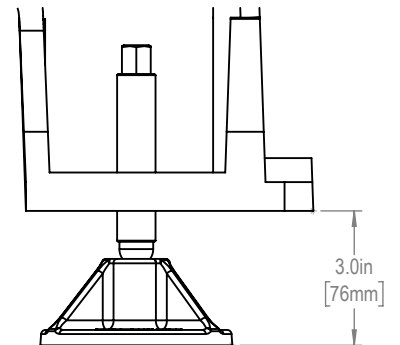

*All Height Dimensions Based on Suggested Leveling Pad Height

Shipping Dimensions

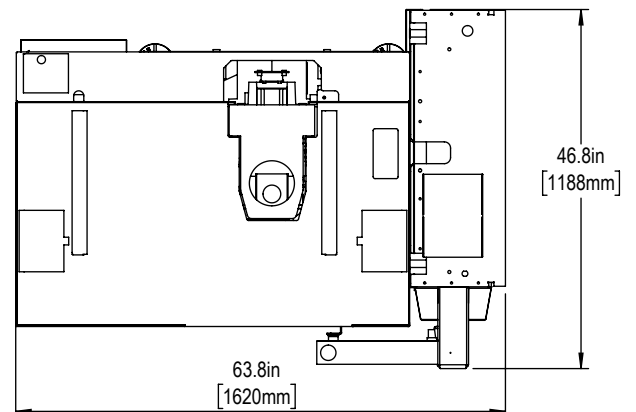
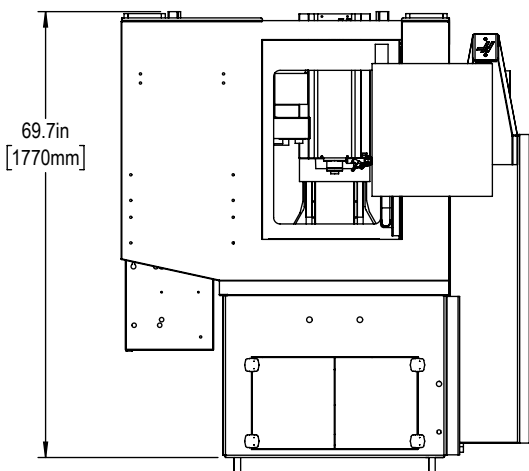

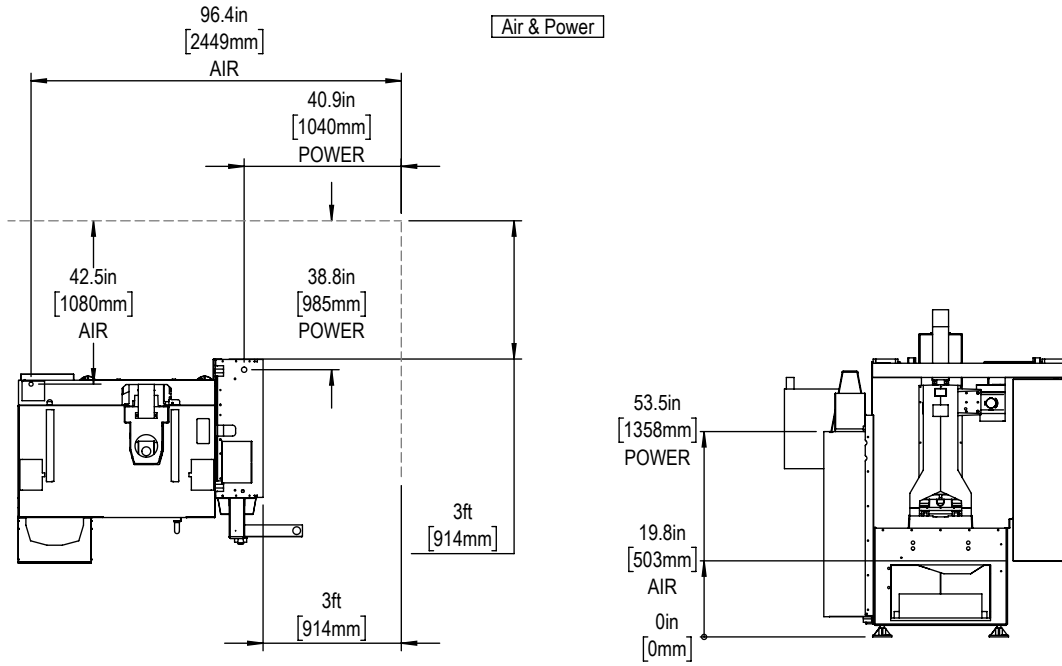

Maintain 3 feet [915mm] clearance to the nearest obstruction around all sides of machine perimeter for maintenance access

Note:
Machine must be placed on one continous concrete slab. Slab should extend 12in [305mm] beyond anchor holes in all directions

Anchor Pattern

Anchor Hole Detail
 Ø 1.0in[25mm]
 ∇ 2.0in[51mm]-
 ∇ 2.5in[64mm]

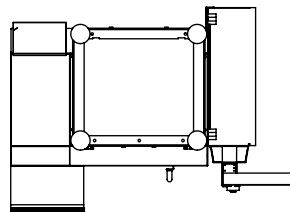



Height Breakdown

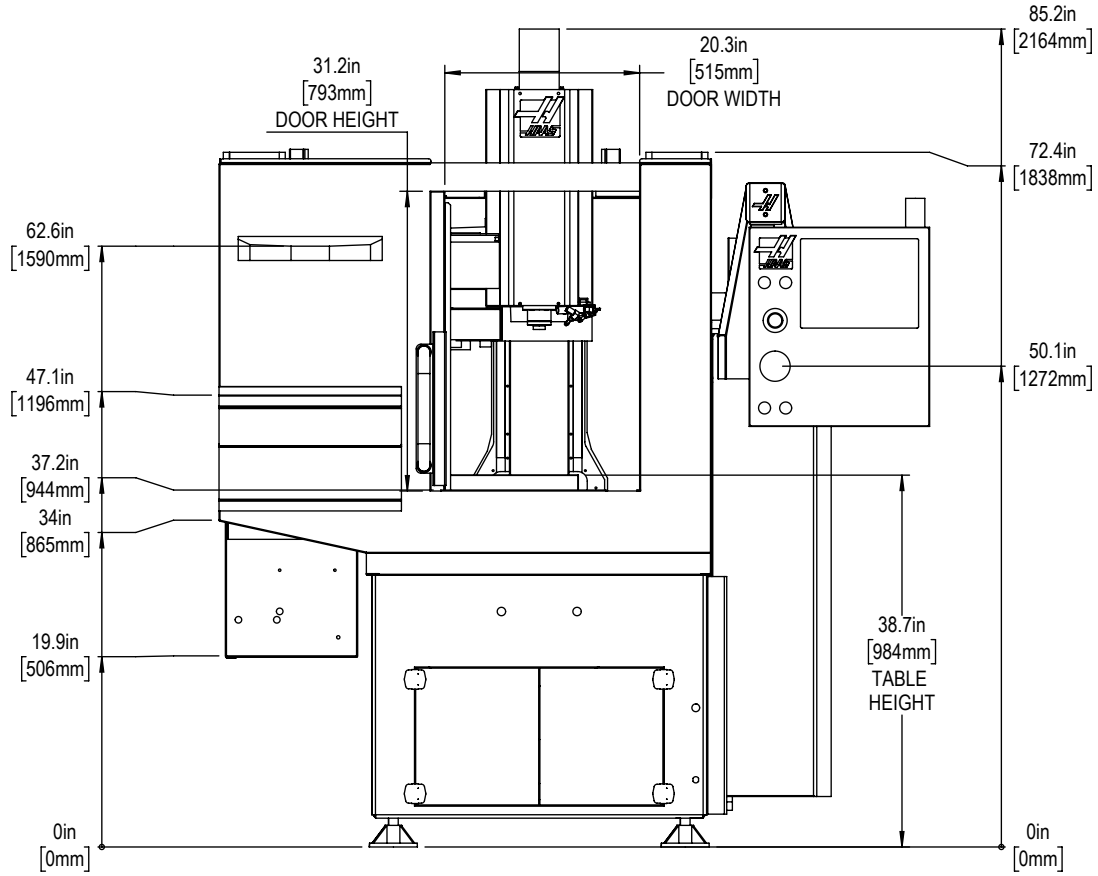

Width Breakdown

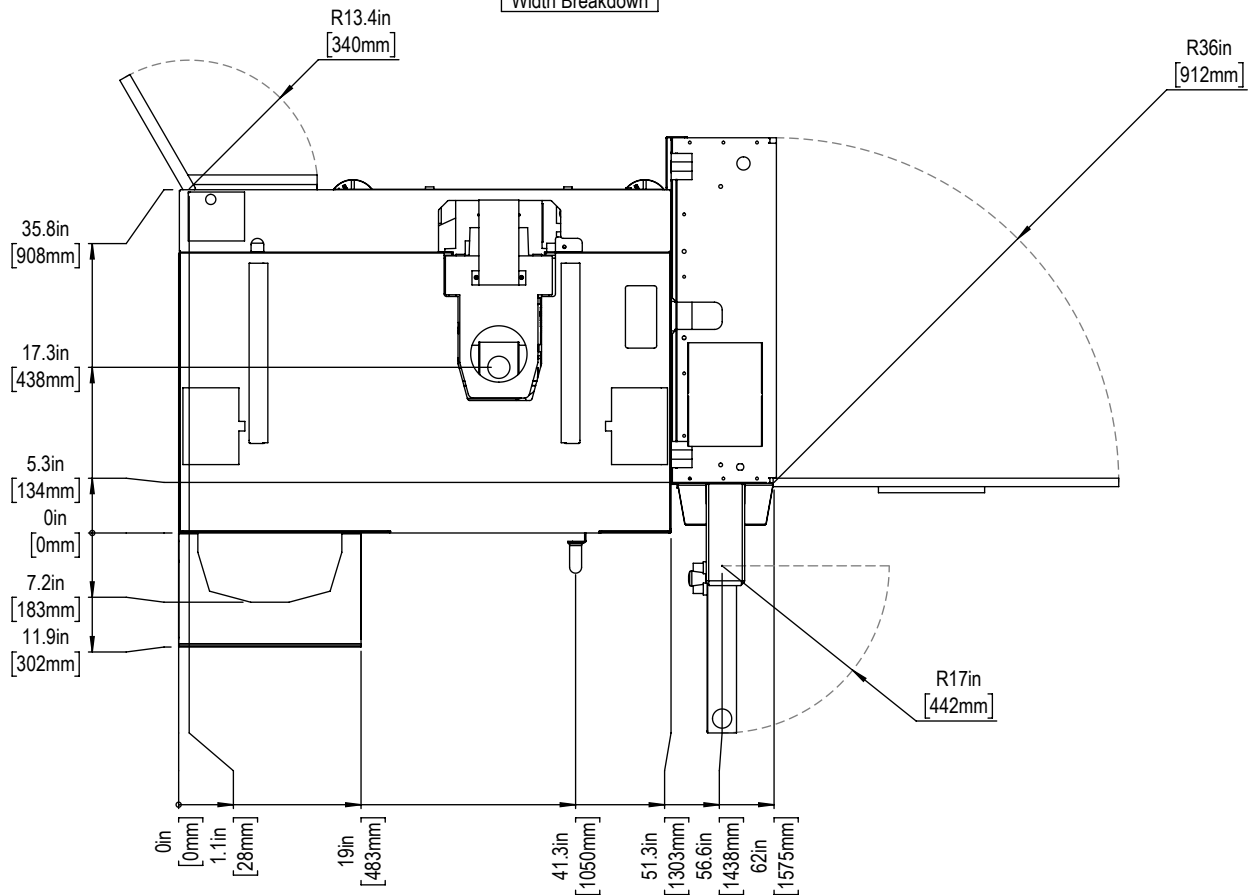



X&Y-Axis Travel and Clearance

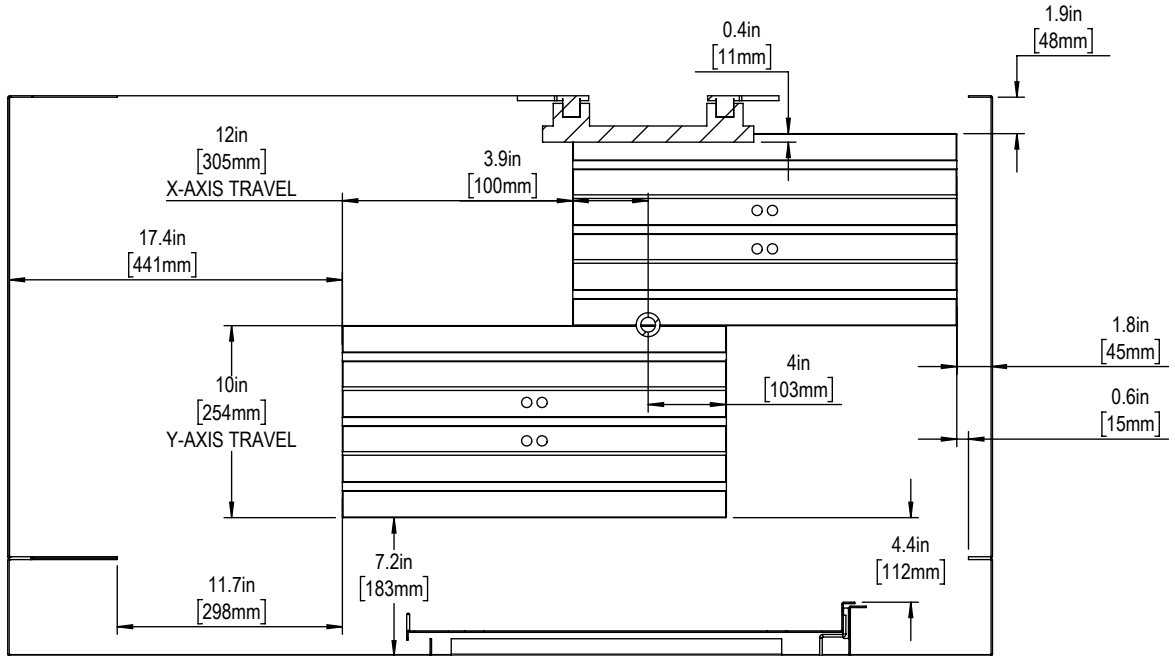

Z-AXIS TRAVEL & CLEARANCE

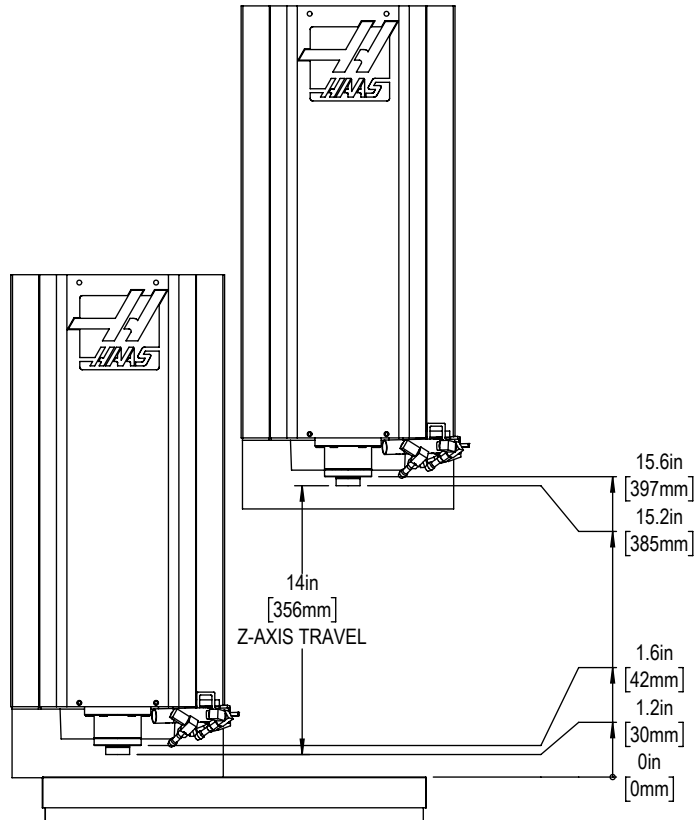

Table

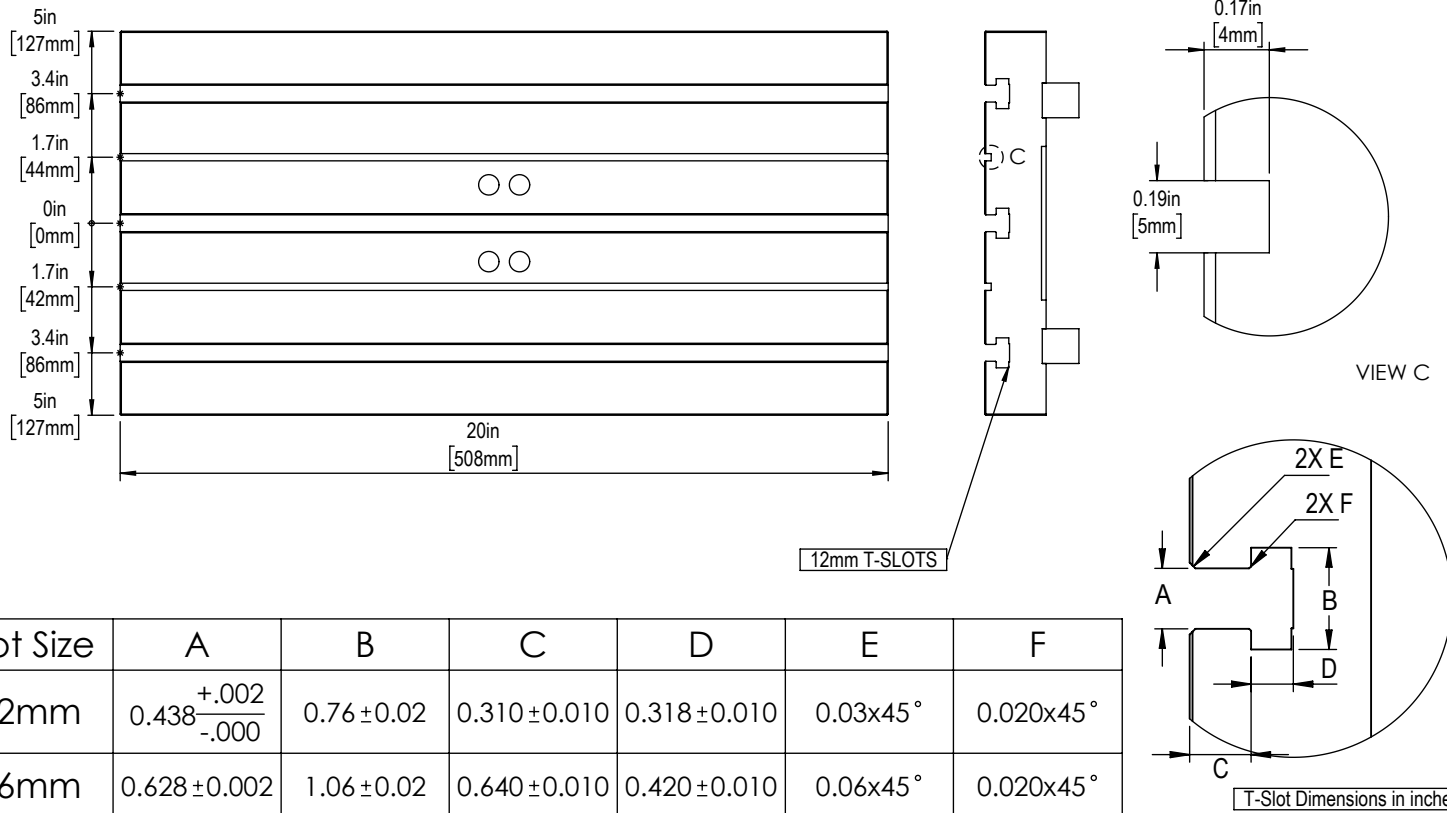

Tool Changer

