

Leveling Pad Detail

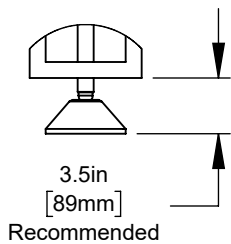

*Due to continual product improvements, machine dimensions are subject to change without notice.

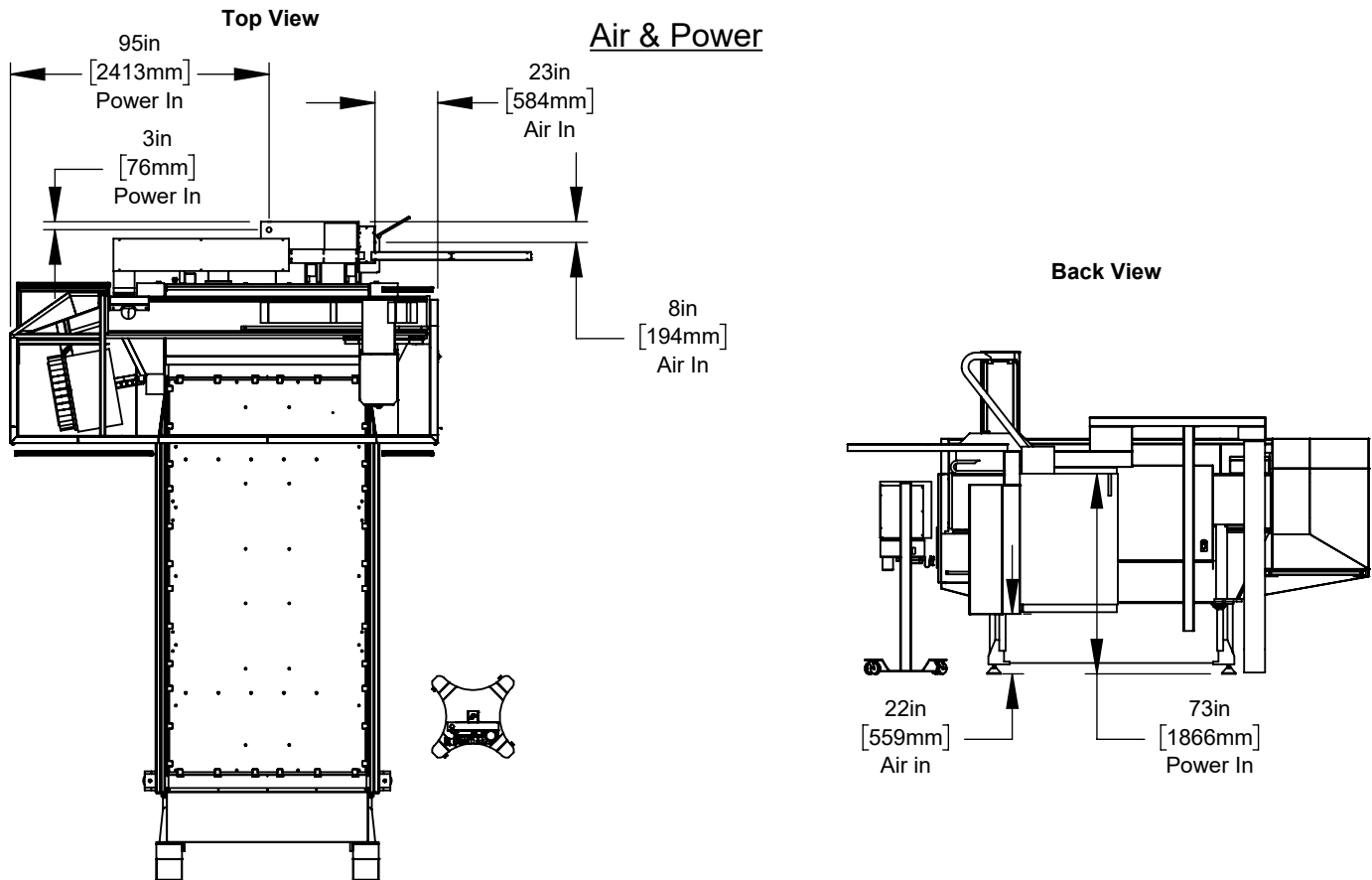

Anchor Pattern

No anchoring kit available at this time

Height Breakdown

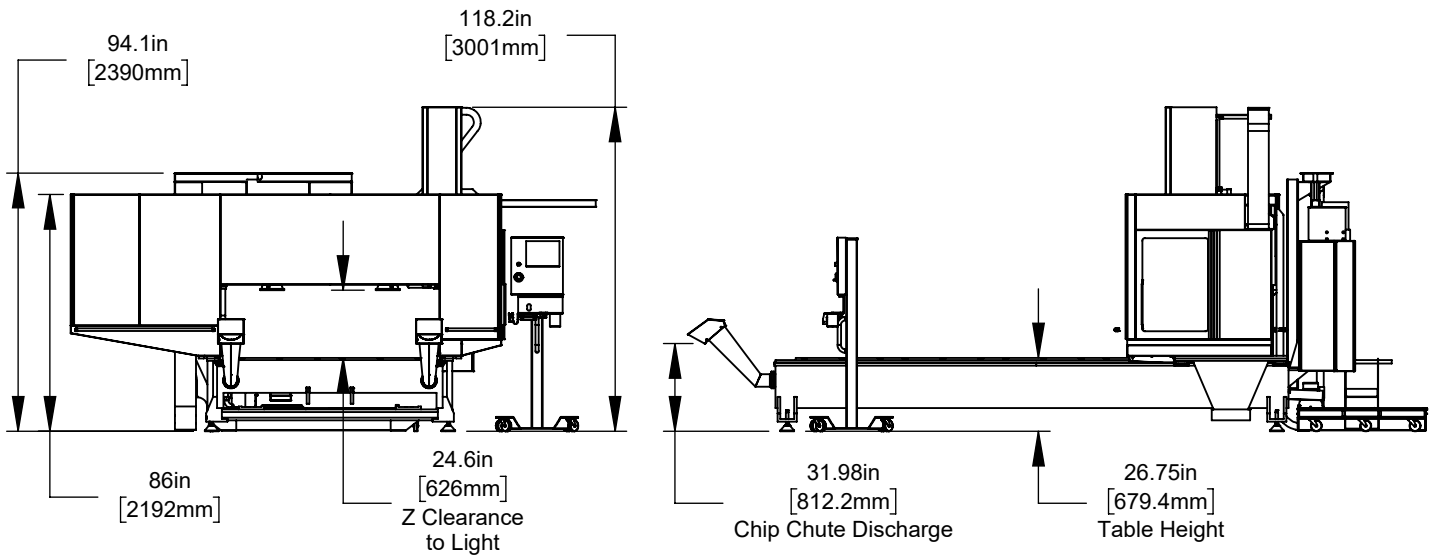

All dimensions based on stackup of sheetmetal, subject to variation of 1/2" (13 mm)

Width Breakdown

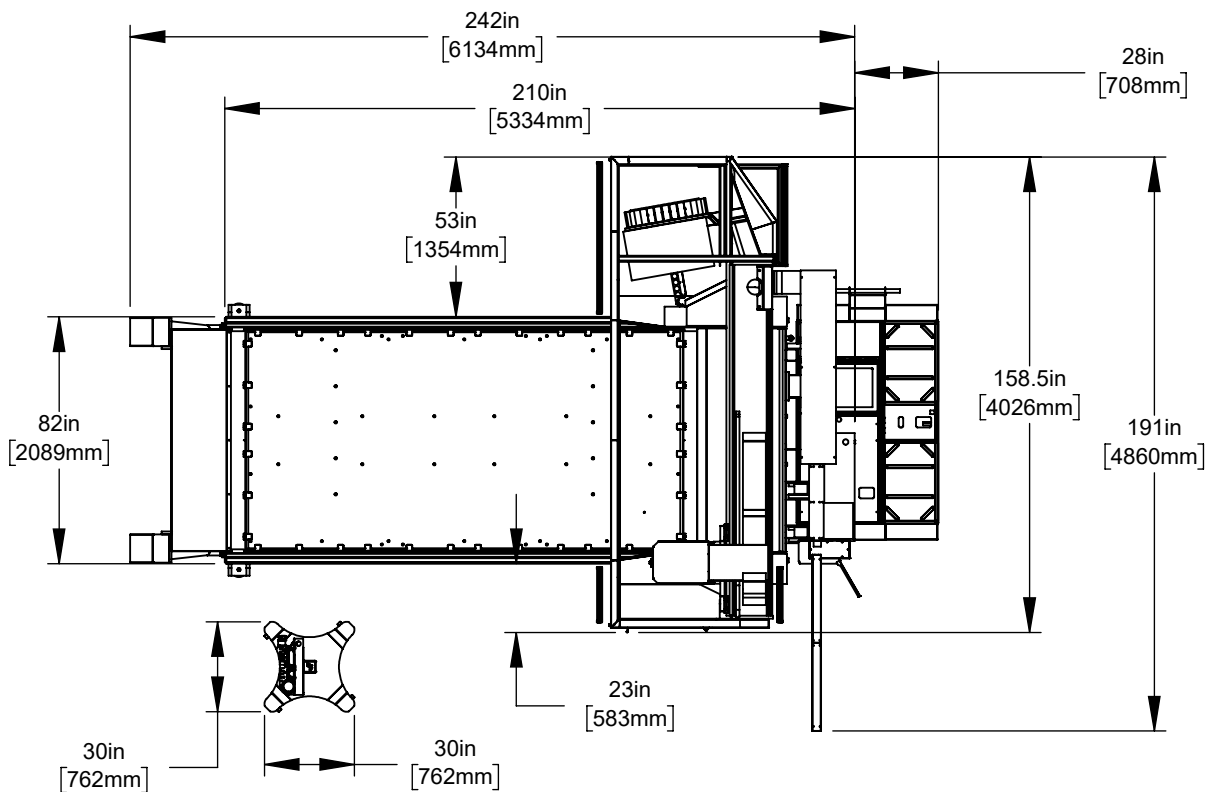

All dimensions based on stackup of sheetmetal, subject to variation of 1/2" (13 mm)

*Due to continual product improvements, machine dimensions are subject to change without notice.

X&Y-Axis Clearance

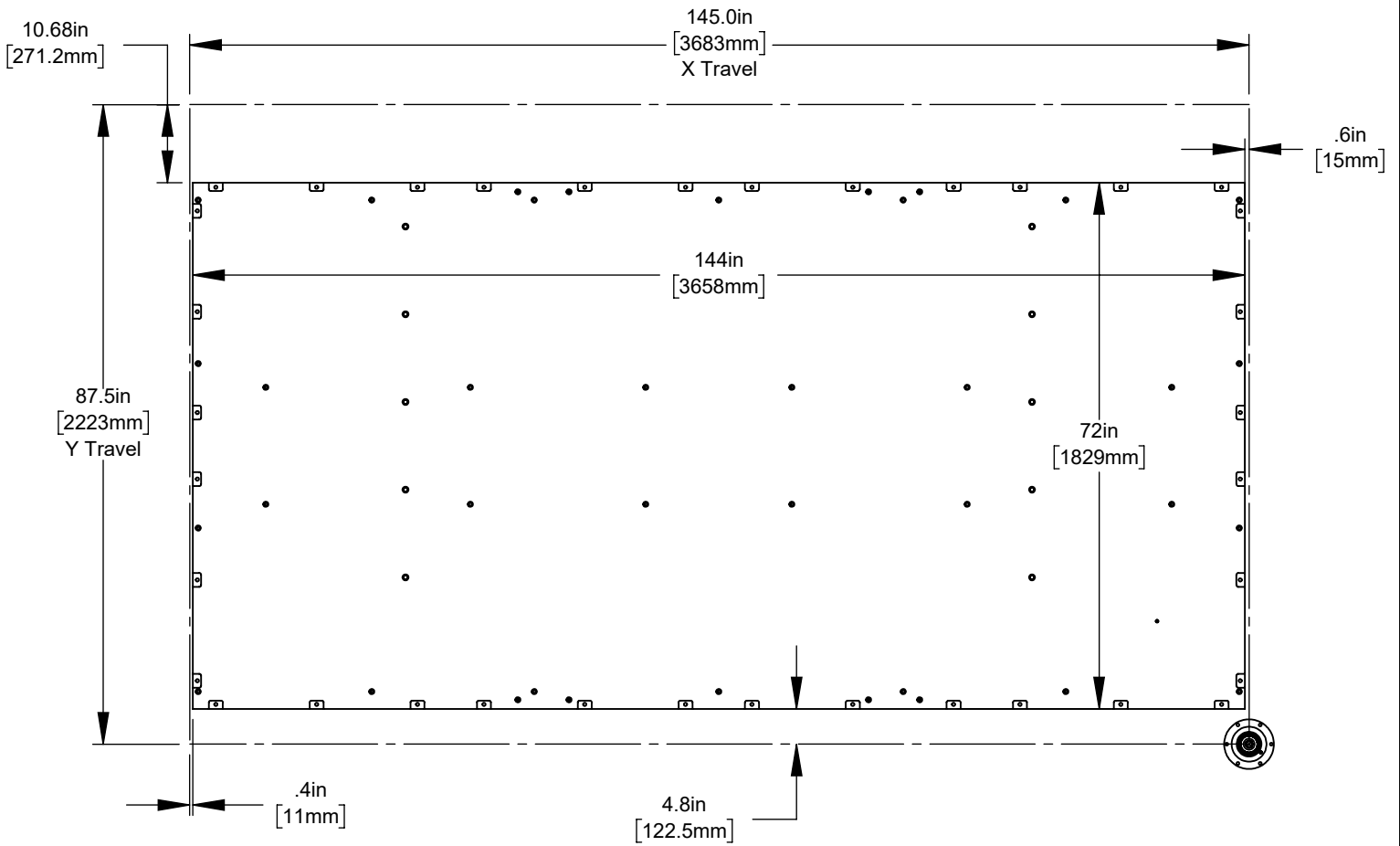

Z-Axis Clearance

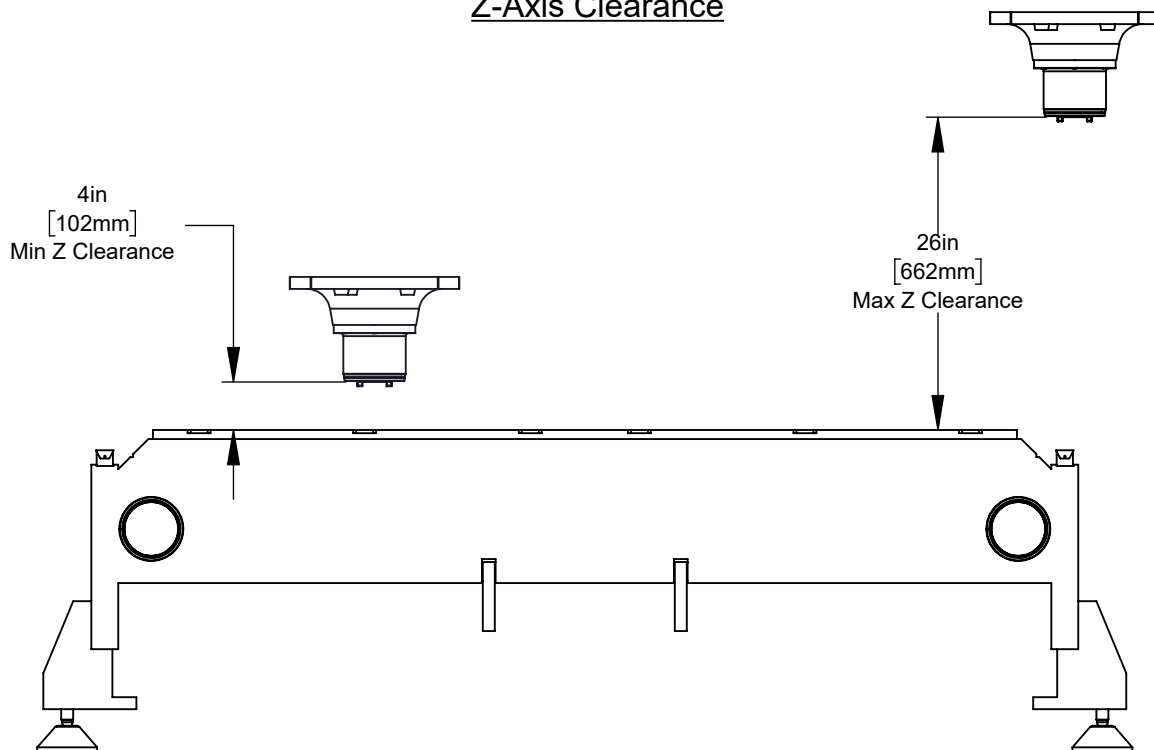

*Due to continual product improvements, machine dimensions are subject to change without notice.

Tool Changer

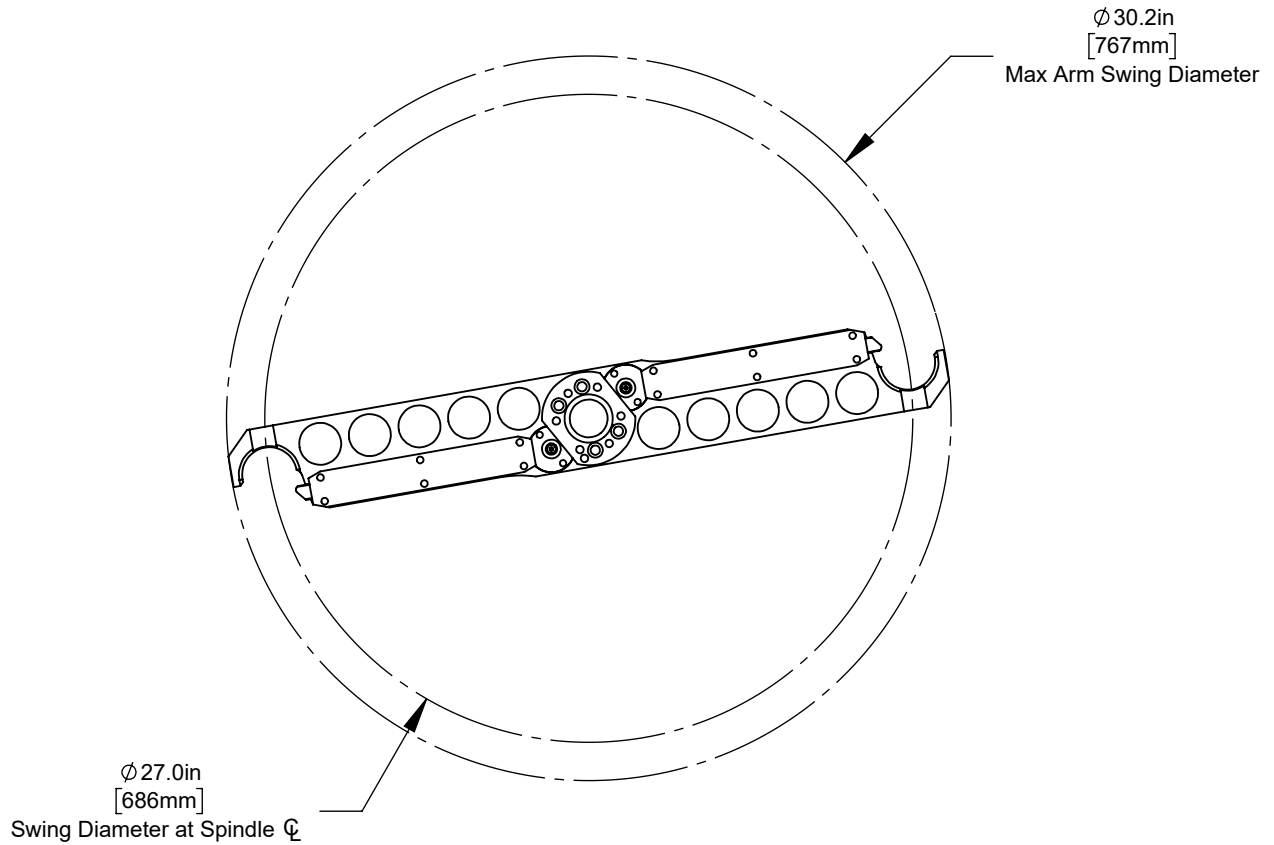
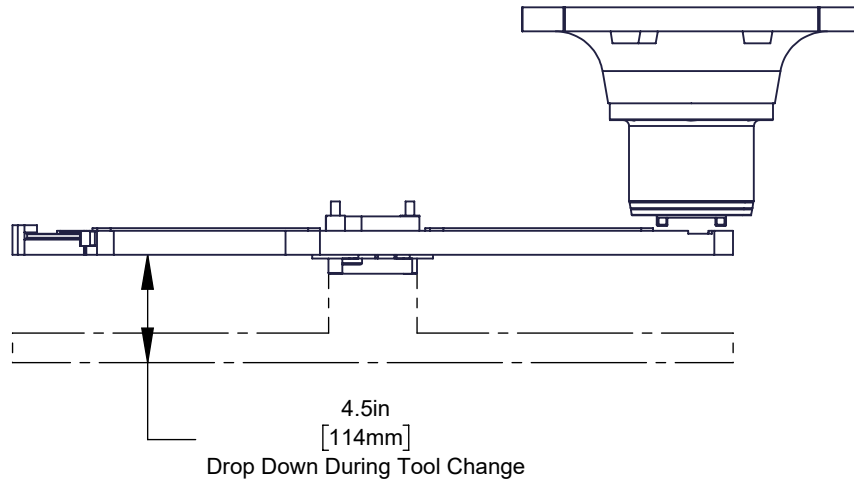

HOLES TABLE		
LTR	DESCRIPTION	QTY
A	Ø .391 THRU, □ Ø .709 T.59	26
B	1/2-13 UNC-2B THRU, □ Ø .709 T.59	4
C	Ø .532 THRU, □ Ø .709 T.59	8
D	Ø .531 THRU, □ Ø .813 T.63	10
E	5/8-16 UNC-2B T.50	1

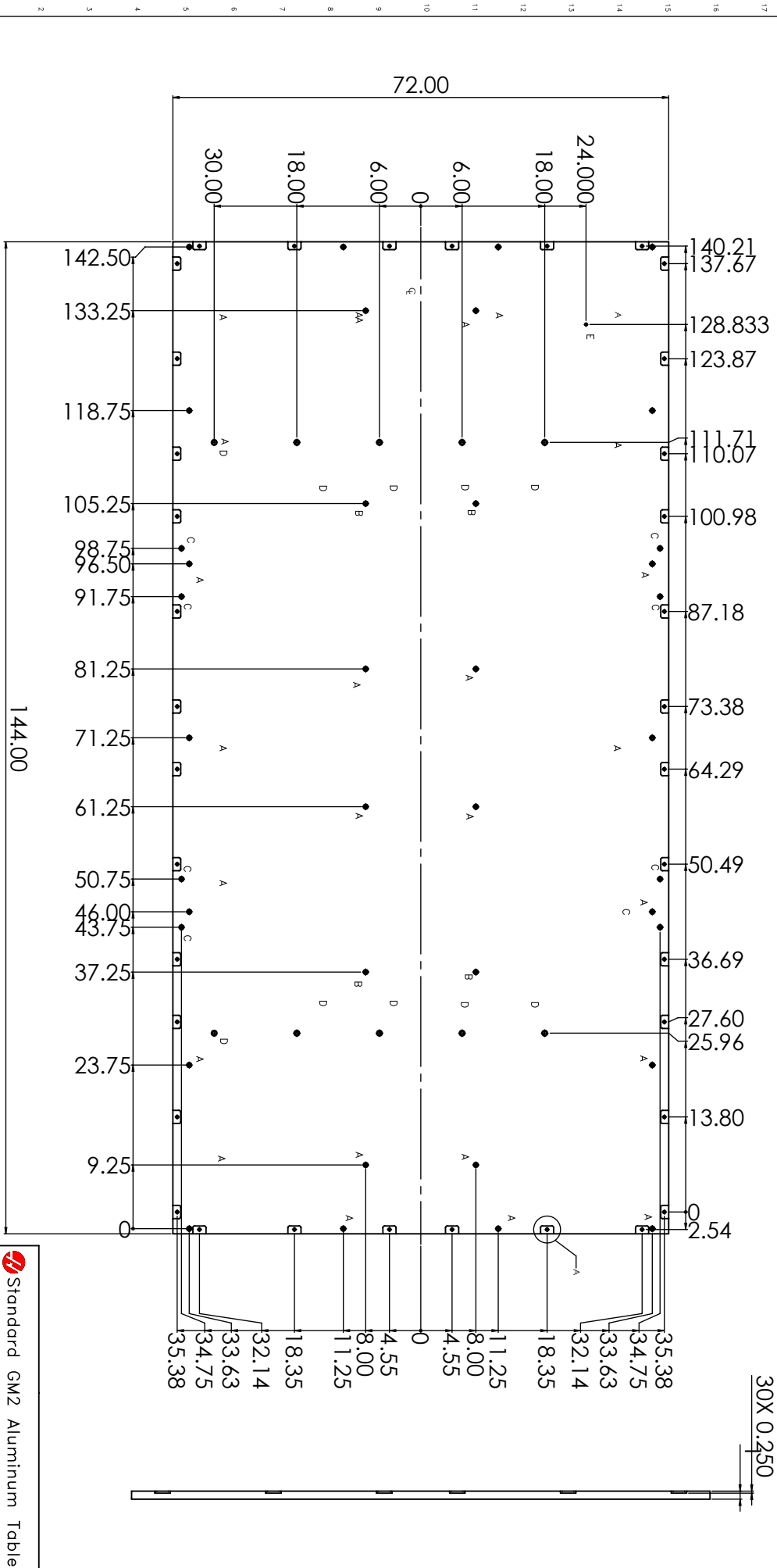

Standard GM2 Aluminum Table

Scale: 1:1.8

Material: Aluminum

Part Number: D

*Due to continual product improvements, machine dimensions are subject to change without notice.

HOLES TABLE		QTY
LTR	DESCRIPTION	
A	Ø.391 THRU, □ Ø.709 TYP. 59	26
B	1/2-13 UNC-2B THRU, □ Ø.709 TYP. 59	4
C	Ø.332 THRU, □ Ø.709 TYP. 59	8
D	Ø.531 THRU, □ Ø.813 TYP. 63	10
E	3/8-16 UNC-2B TYP. 50	1
F	1/2-13 UNC-2B TYP. 75 DO NOT BREAK THRU	594

NOTES: UNLESS OTHERWISE SPECIFIED
1. ALL UNMARKED HOLES ARE 'F' HOLES

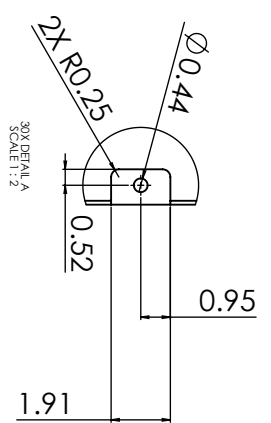
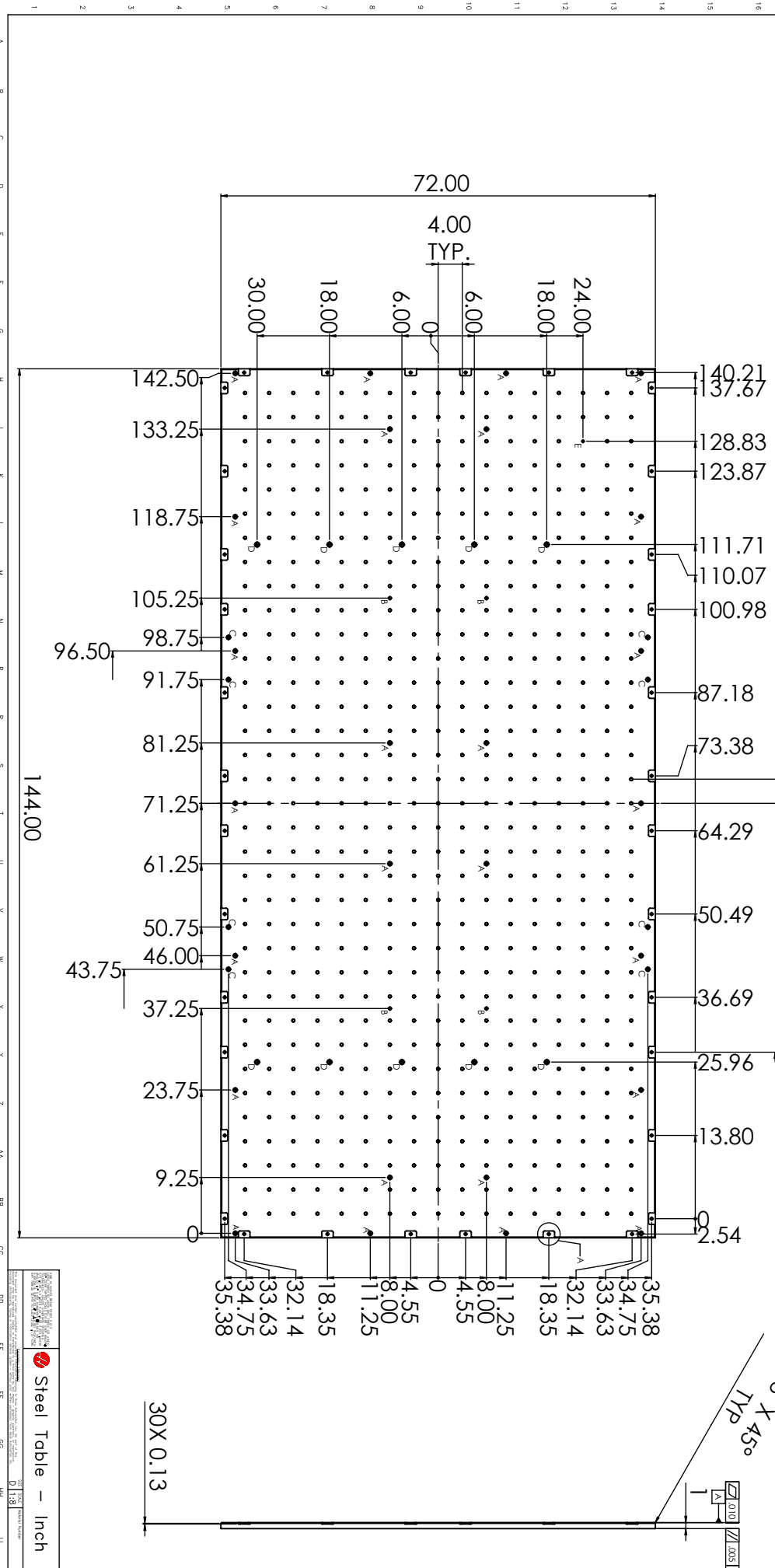

Steel Table - Inch

30X 0.13

*Due to continual product improvements, machine dimensions are subject to change without notice.

HOLES TABLE		
LTR	DESCRIPTION	QTY
A	Ø10mm THRU, L Ø18mm x 15mm	26
B	1/2-13 UNC-2B THRU, L Ø18mm x 16mm	4
C	Ø8.45mm THRU, L Ø18mm x 15mm	8
D	Ø13.48mm THRU, L Ø20.65mm x 16mm	10
E	3/8-16 UNC-2B x 12.7mm	1
F	M12 X 1.75 x 19mm DO NOT BREAK THRU	595

NOTES: UNLESS OTHERWISE SPECIFIED
1. ALL UNMARKED HOLES ARE 'F' HOLES

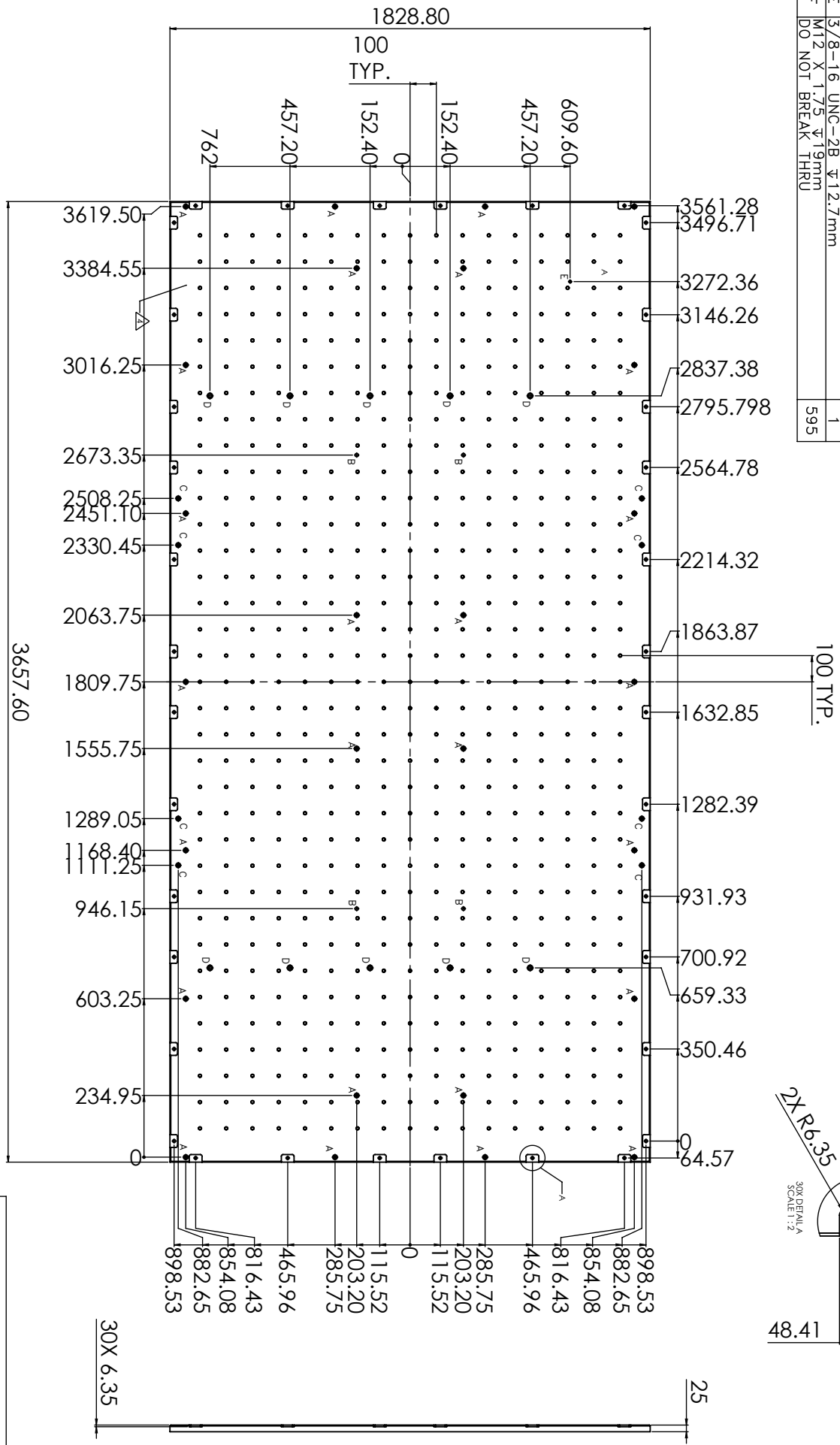

Steel Table - Metric

*Due to continual product improvements, machine dimensions are subject to change without notice.