

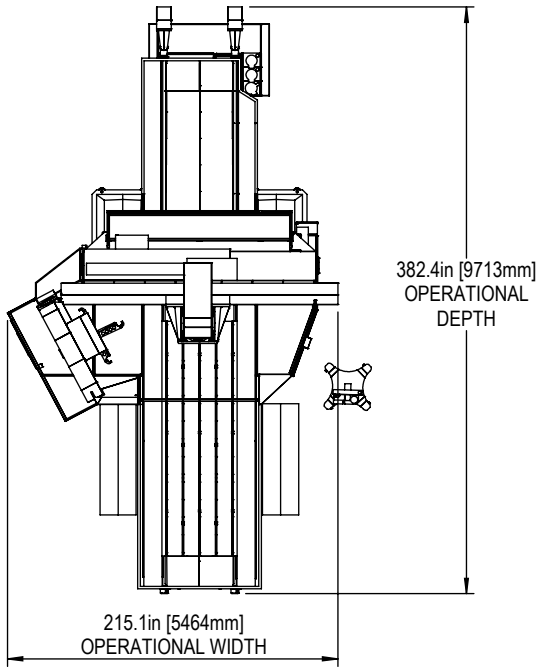

Installed Dimensions

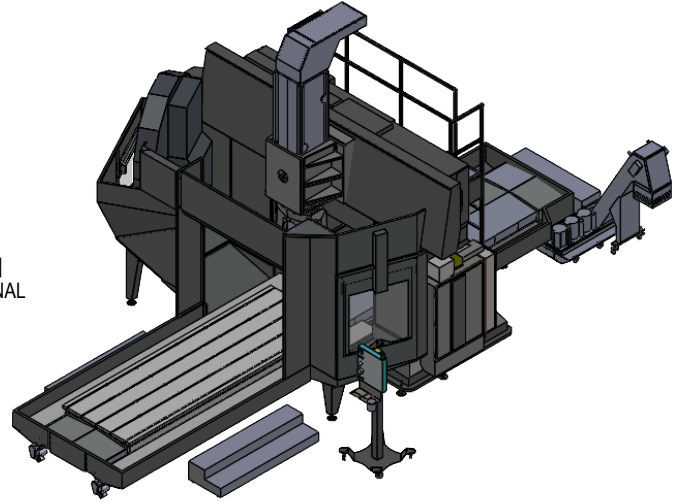

Leveling Pad Height

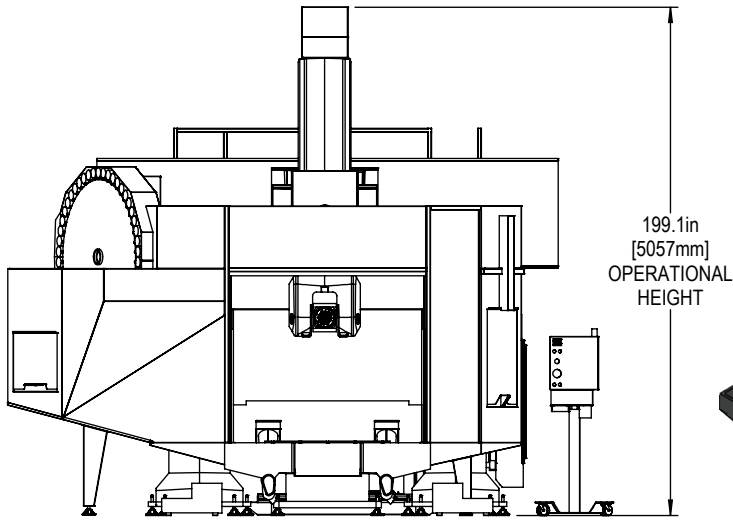
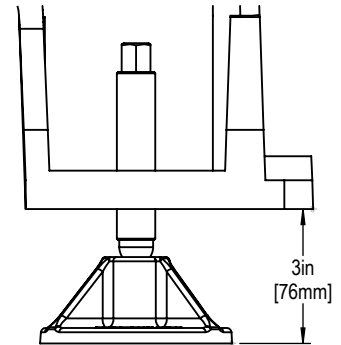

\*All Height Dimensions Based on Suggested Leveling Pad Height

Shipping Dimensions

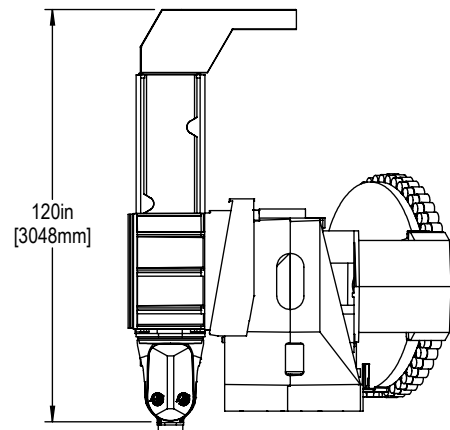
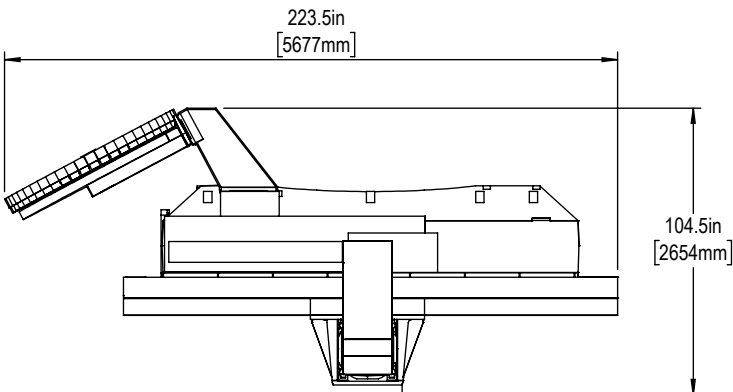

TABLE SHIPPING SIDE CLEARANCE

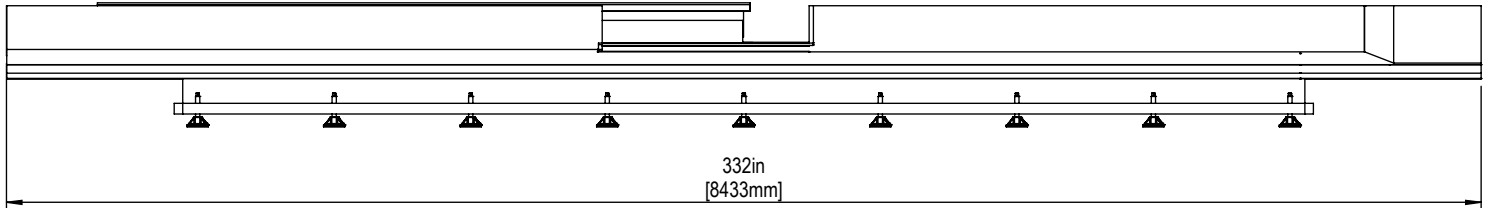
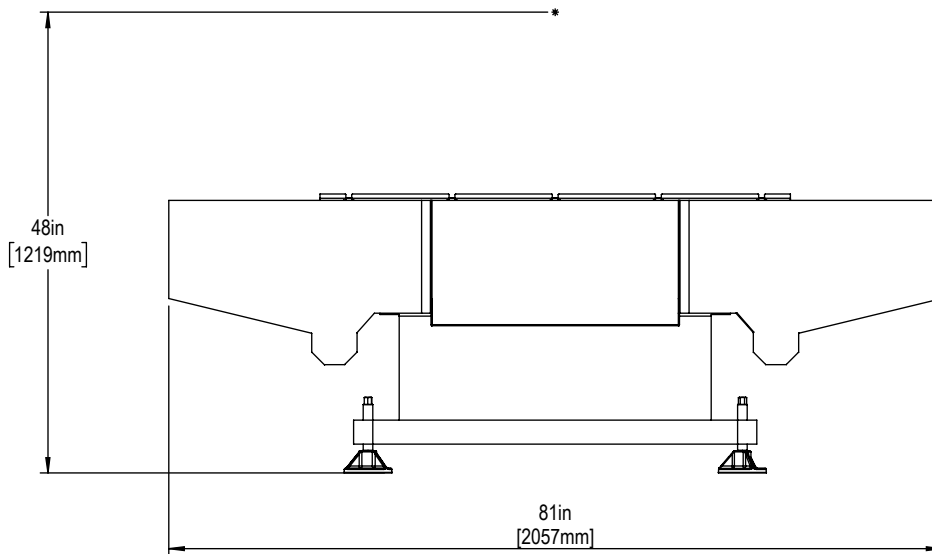
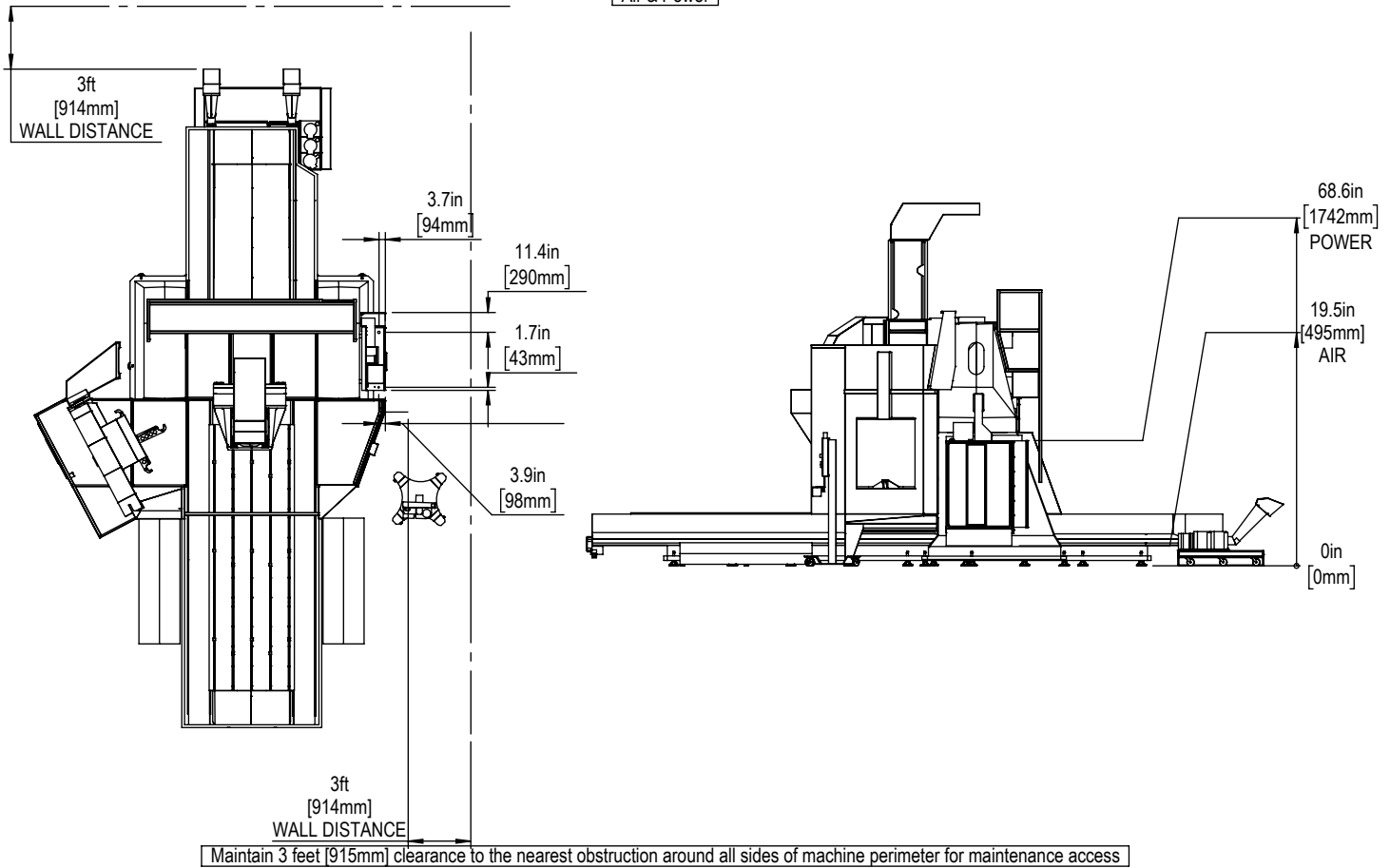

TABLE SHIPPING FRONT CLEARANCE

Note: Allow a height clearance of at least 48in [1219mm] for additional components shipped with table.



Air & Power



Note:

Thoroughly clean and dry the cored holes. The holes must be free of oil and water. If blasting with air, ensure that the air is free of oil.

See Haas website for more information on Epoxy type and hardware installation instructions.

Anchor Pattern

Anchor Hole Detail  
 Ø 1.5in [38mm]  
 ▽ 8.5in [216mm]

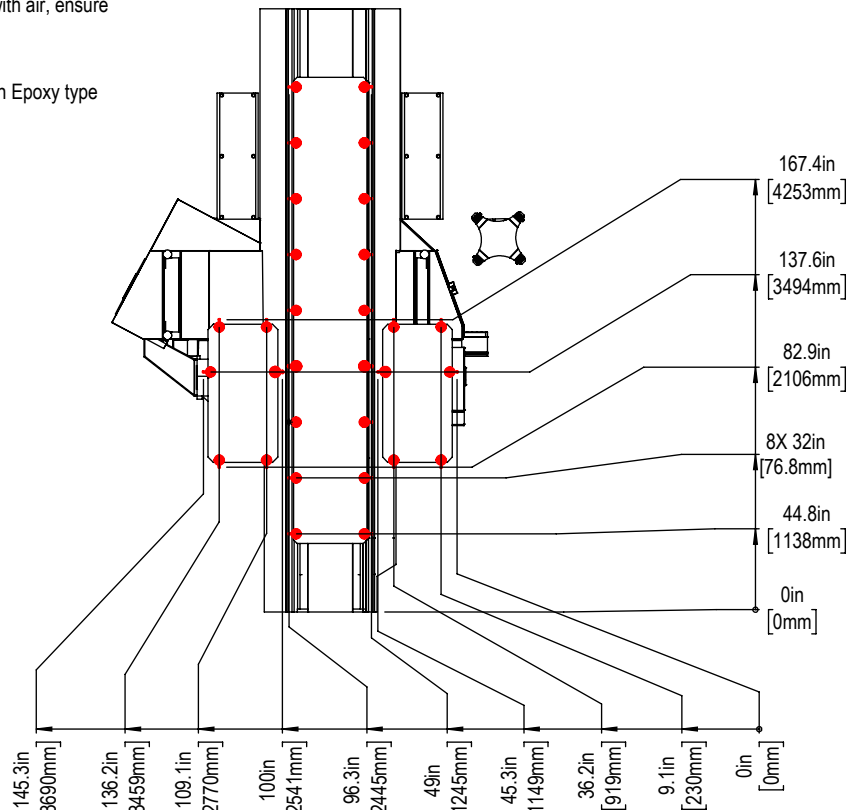

For precise locations and specifications please use template in Anchoring Kit found at Haascnc.com



Height Breakdown

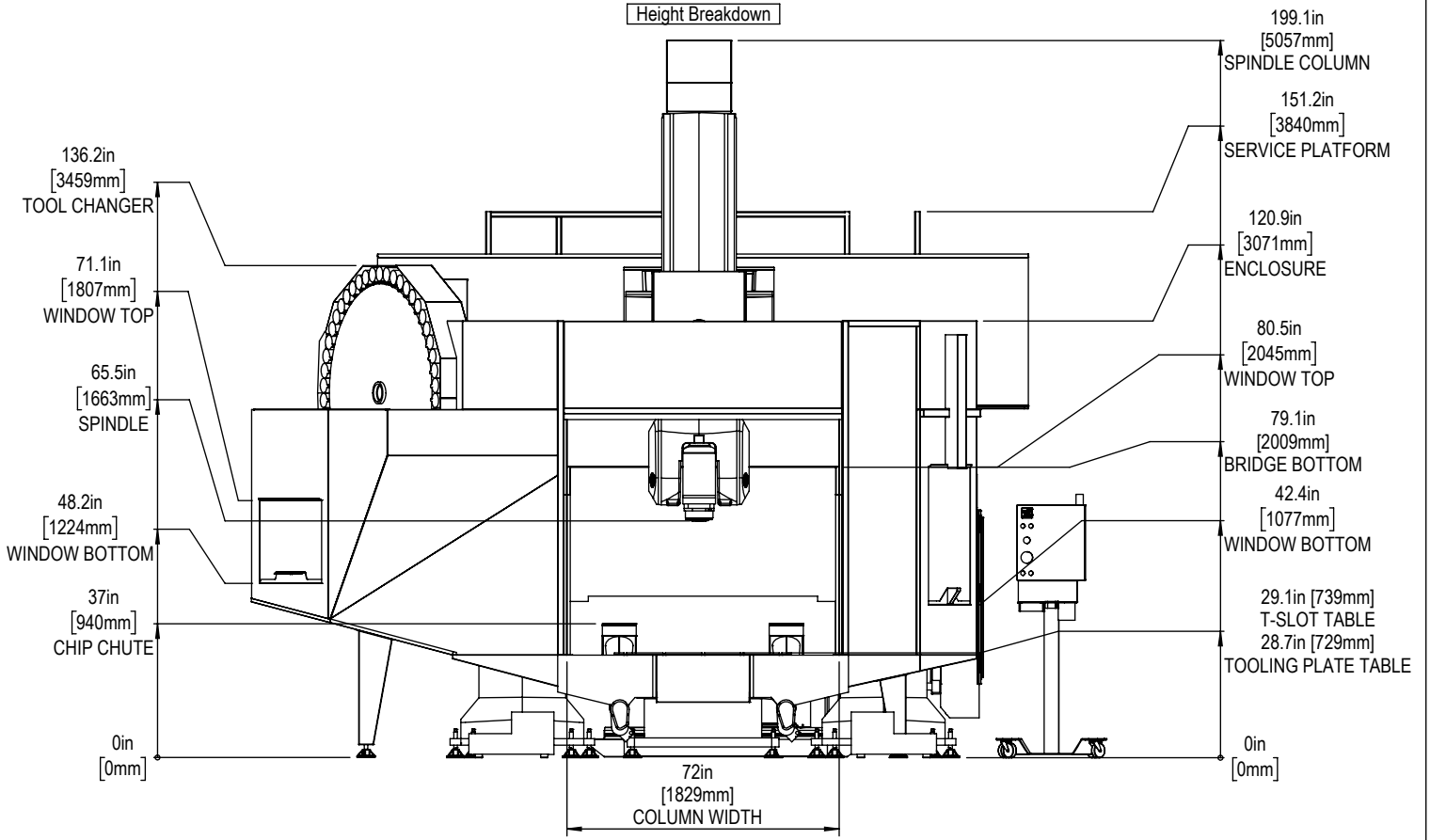

Width Breakdown

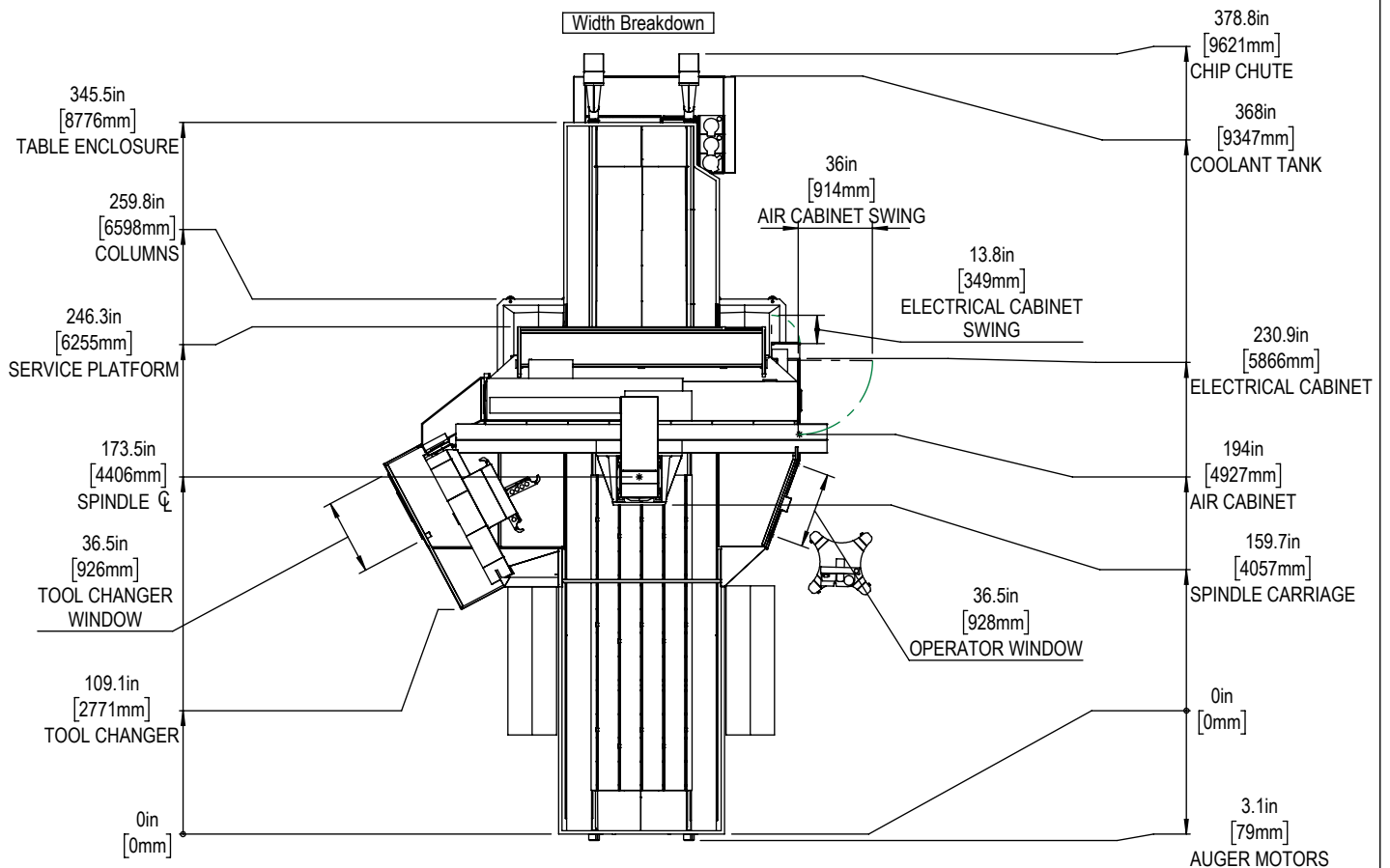

X&Y-Axis Travel and Clearance

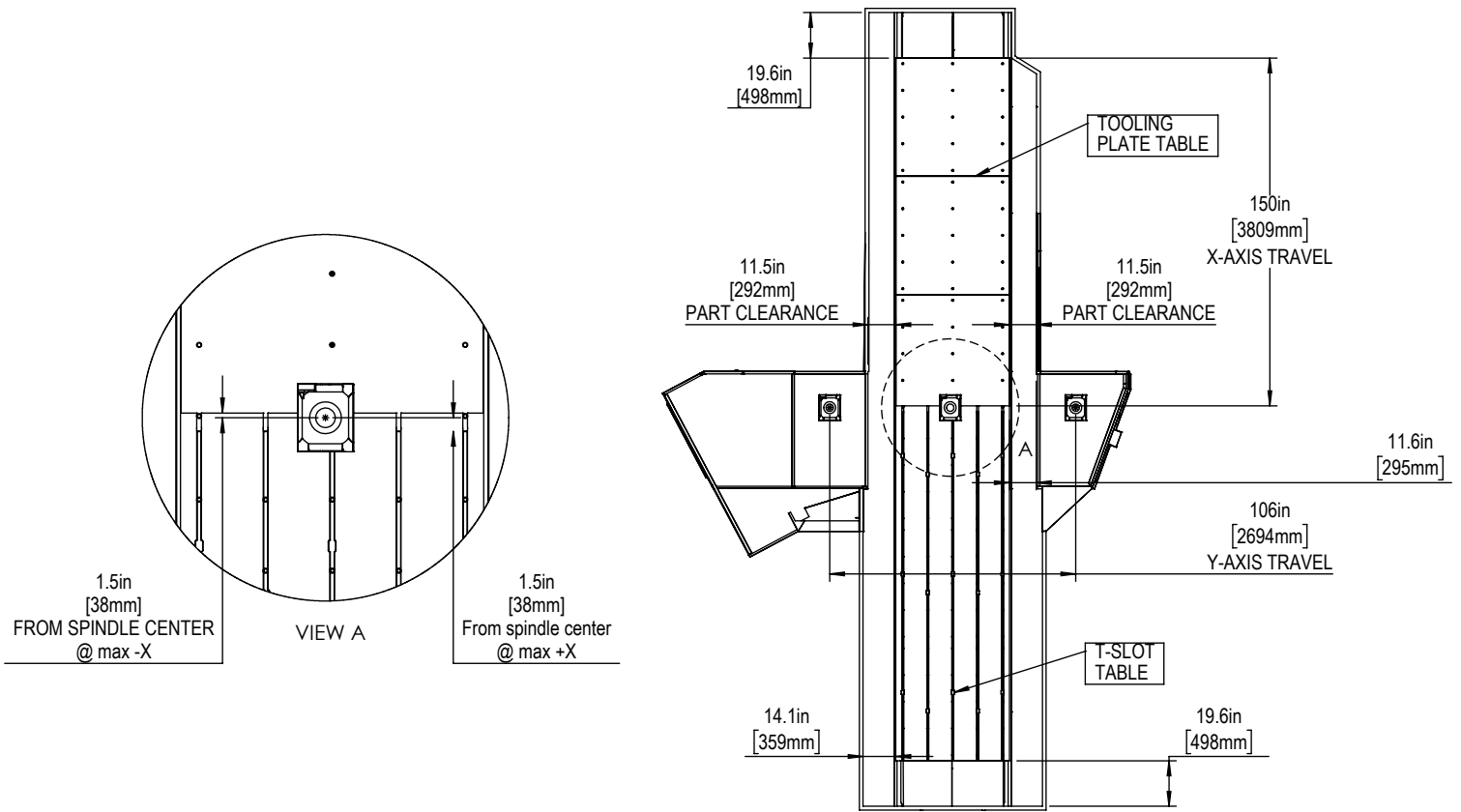

Z-AXIS TRAVEL & CLEARANCE

\*STANDARD TOOLING PLATE TABLE IS 1.6in [41mm] THICK  
 \*\*OPTIONAL T-SLOT TABLE PLATE IS 2.0in [51mm] THICK

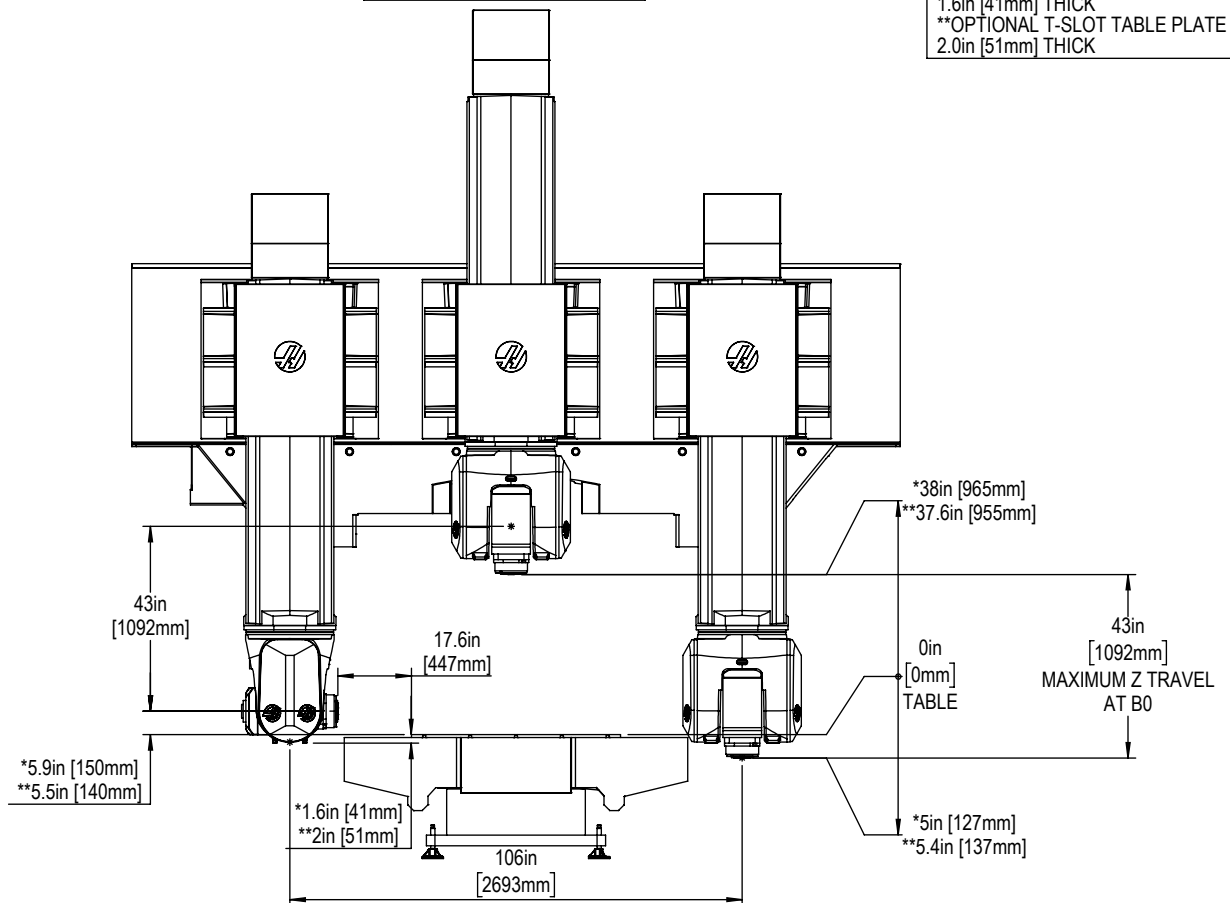

TOOL CHANGER ARM CLEARANCES

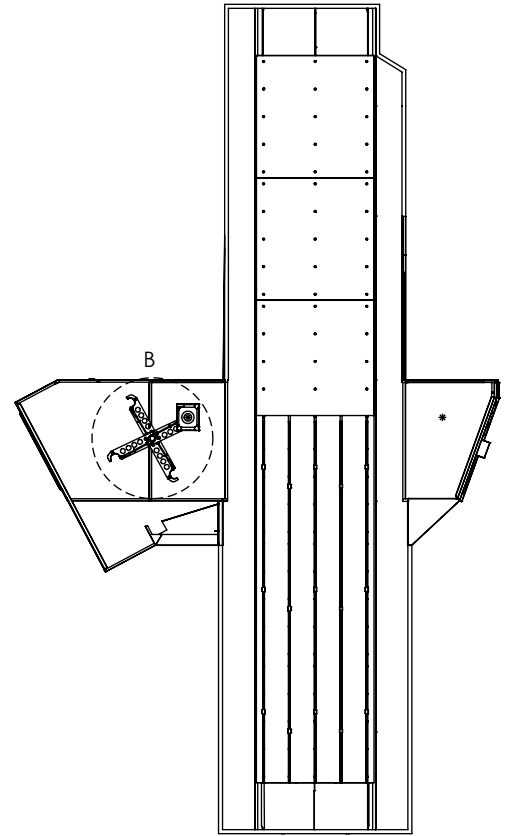
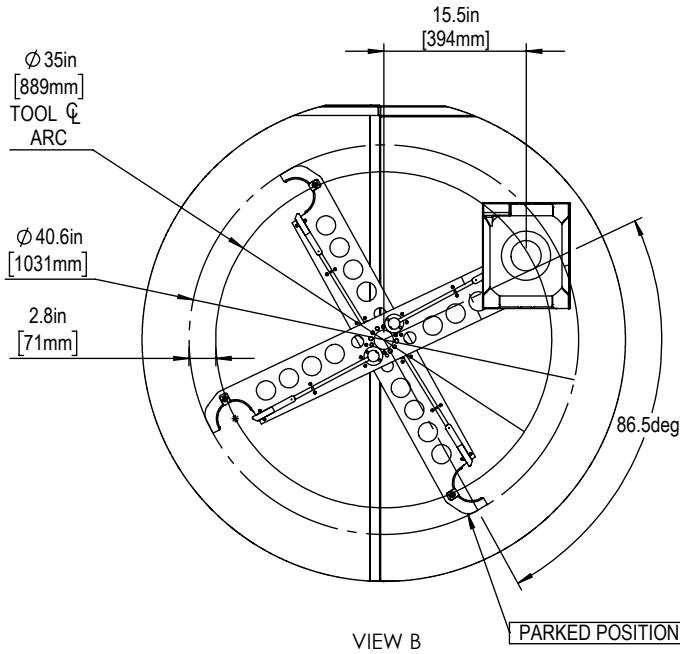

Z-AXIS TRAVEL & CLEARANCE

\*TOOLING PLATE TABLE  
\*\*T-SLOT PLATE TABLE

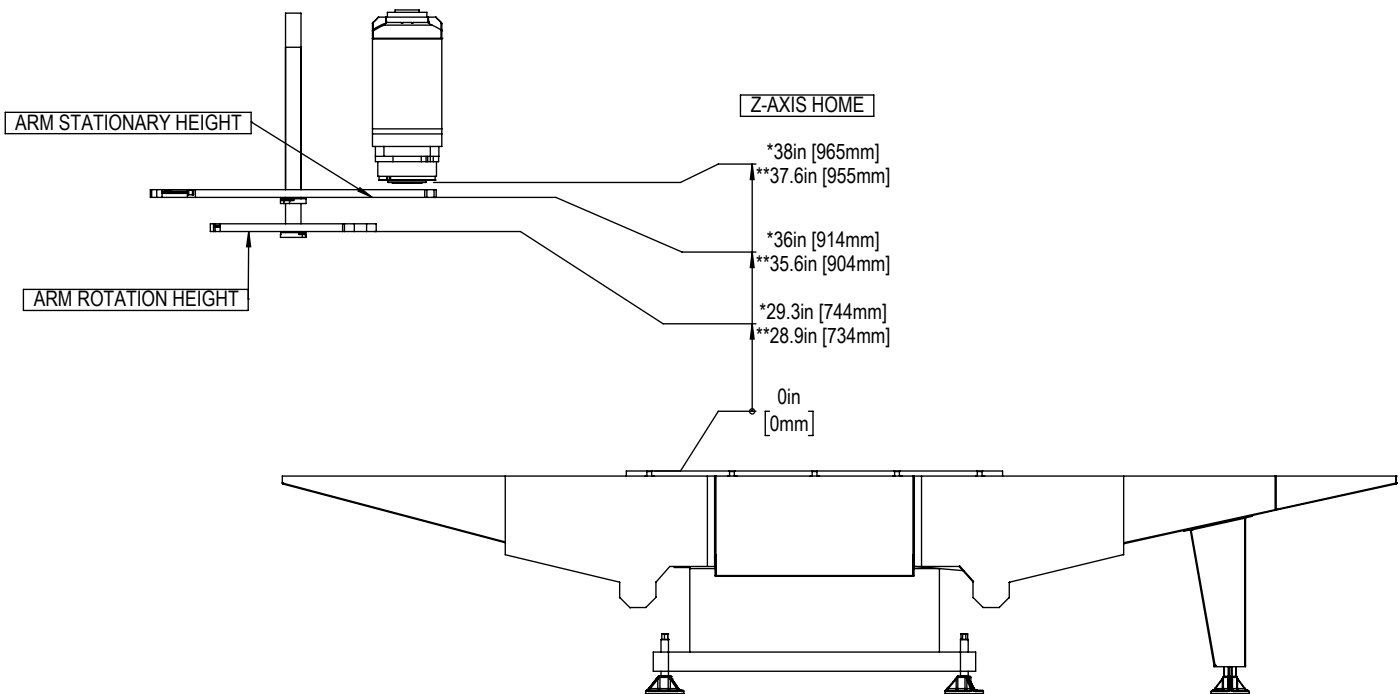

X&Y-Axis Travel and Clearance

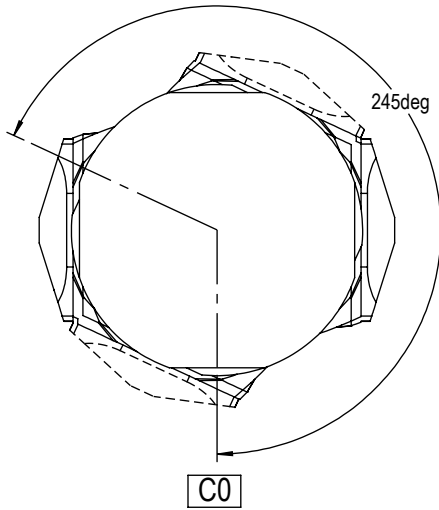

+245° C-AXIS ROTATION  
(COUNTER-CLOCKWISE)

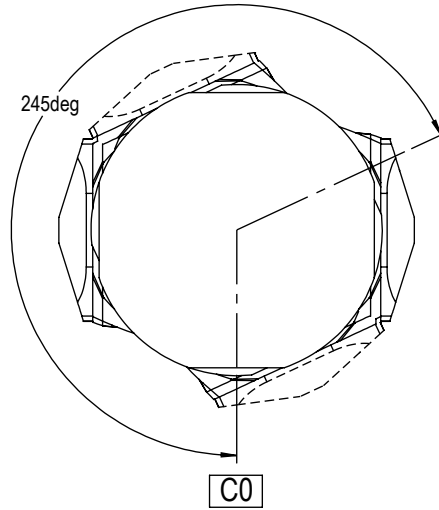

-245° C-AXIS ROTATION  
(CLOCKWISE)

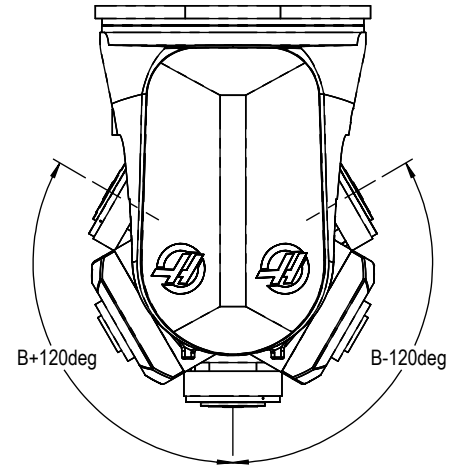

B Axis Tilt limits

YOKE & SPINDLE DIMENSIONS

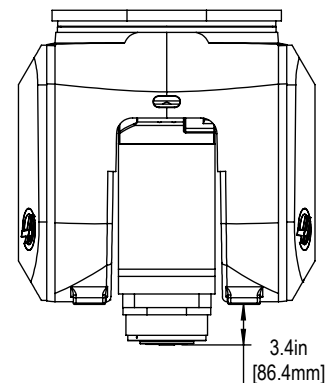
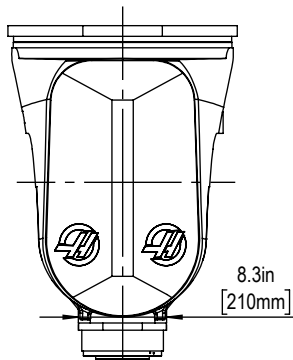
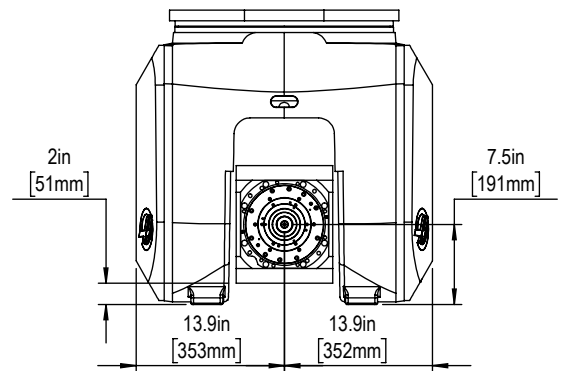
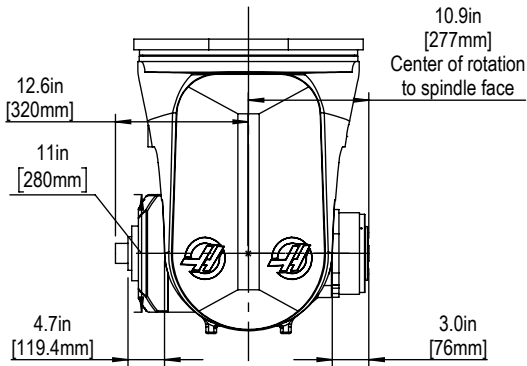

Minimum Z height to reach B120°

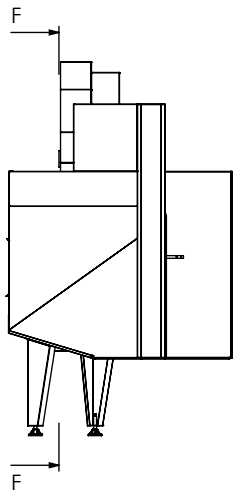
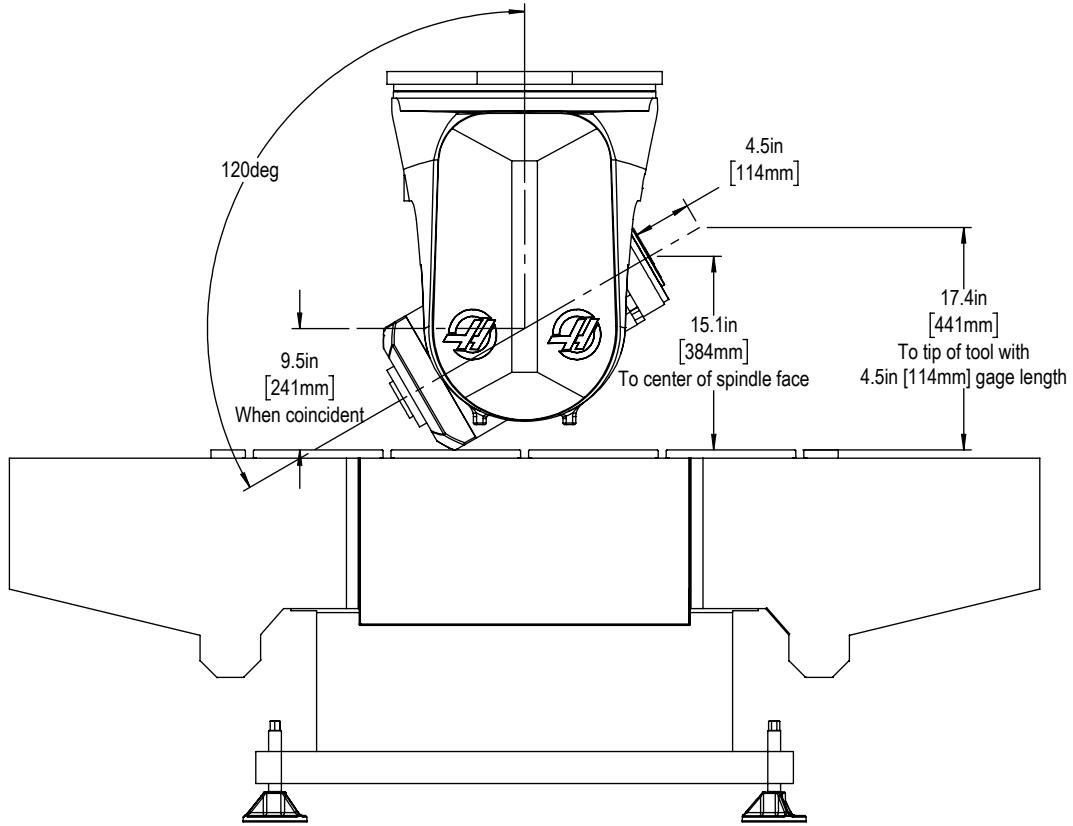

Tool Changer

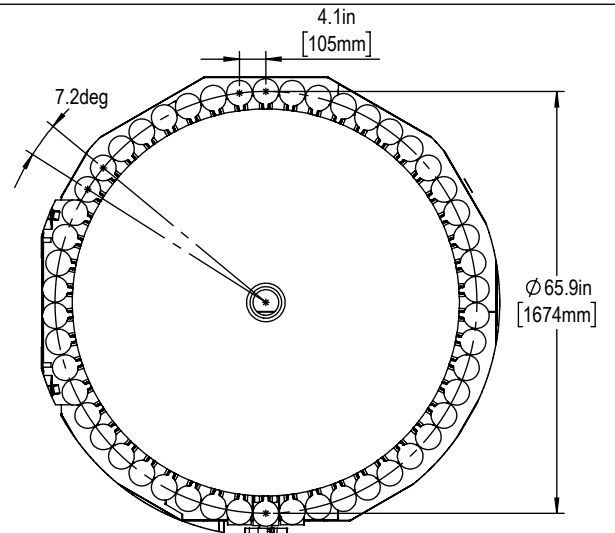
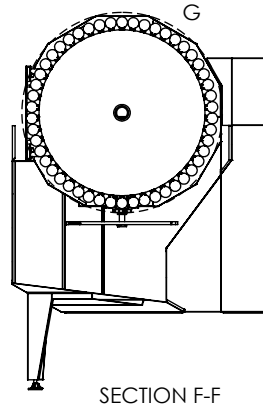

VIEW G

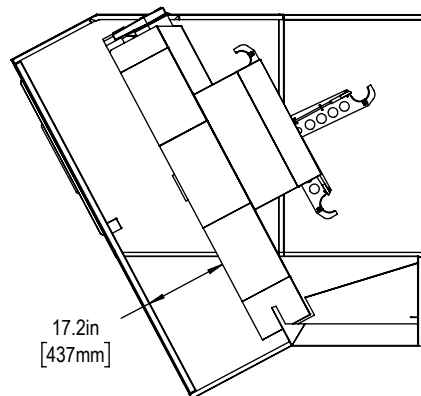



T-Slot Table

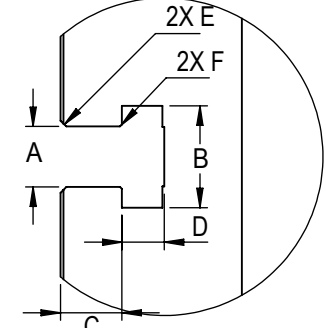
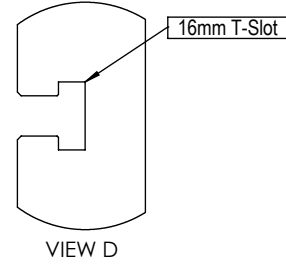
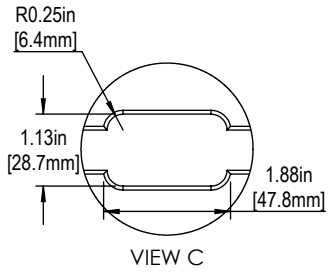
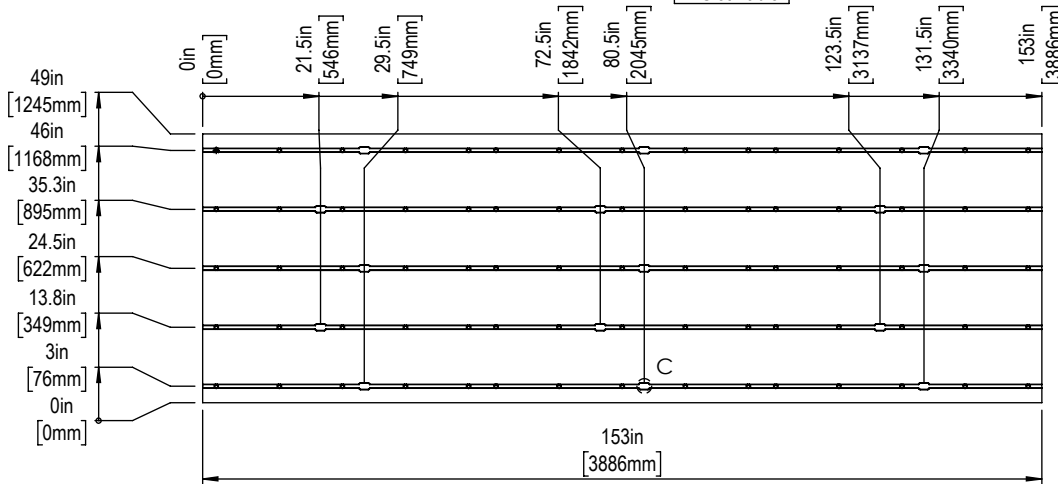

Slot Size	A	B	C	D	E	F
16mm	0.628±0.002	1.06±0.02	0.640±0.010	0.420±0.010	0.06x45°	0.020x45°

T-Slot Dimensions in inches

Threaded Table

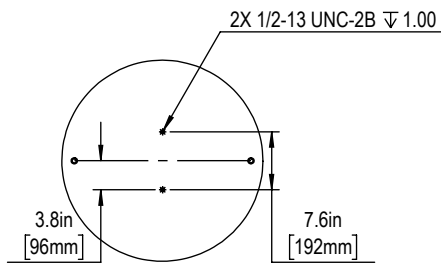
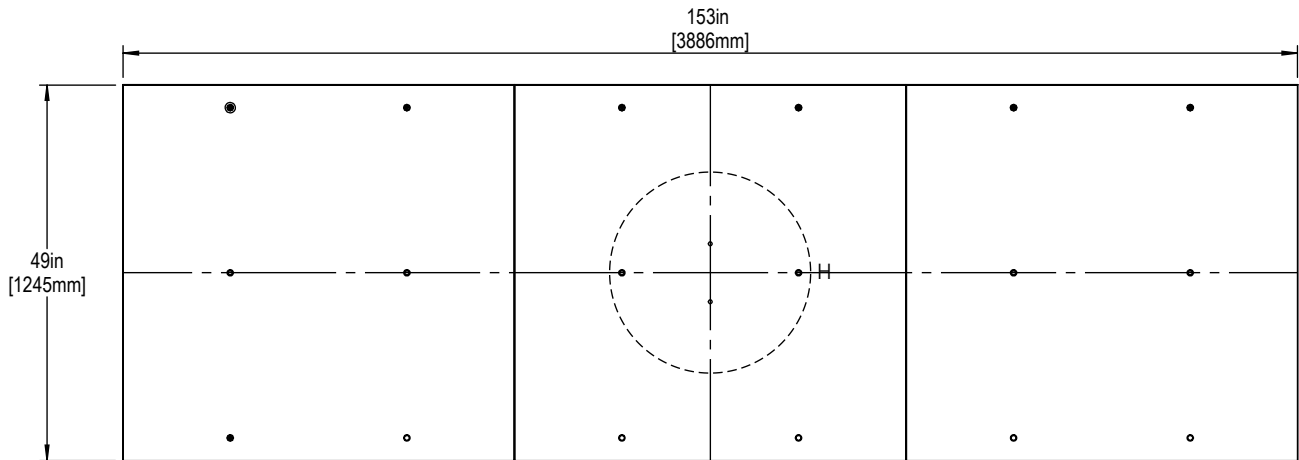

VIEW H  
MRZP TOOLING BOLT HOLES

**NOTE: CONSULT THE NO-CUT ZONE PAGE BEFORE DRILLING OR TAPPING ON THE TABLE TO AVOID ANY DAMAGE TO CRITICAL COMPONENTS**

Table Truck

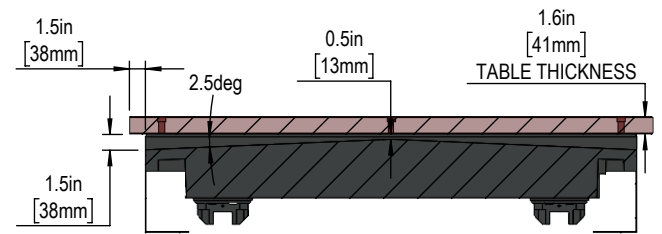
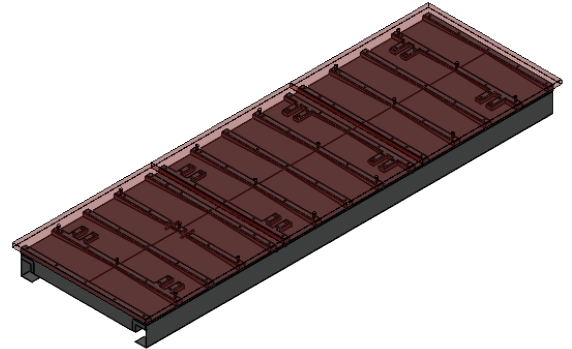
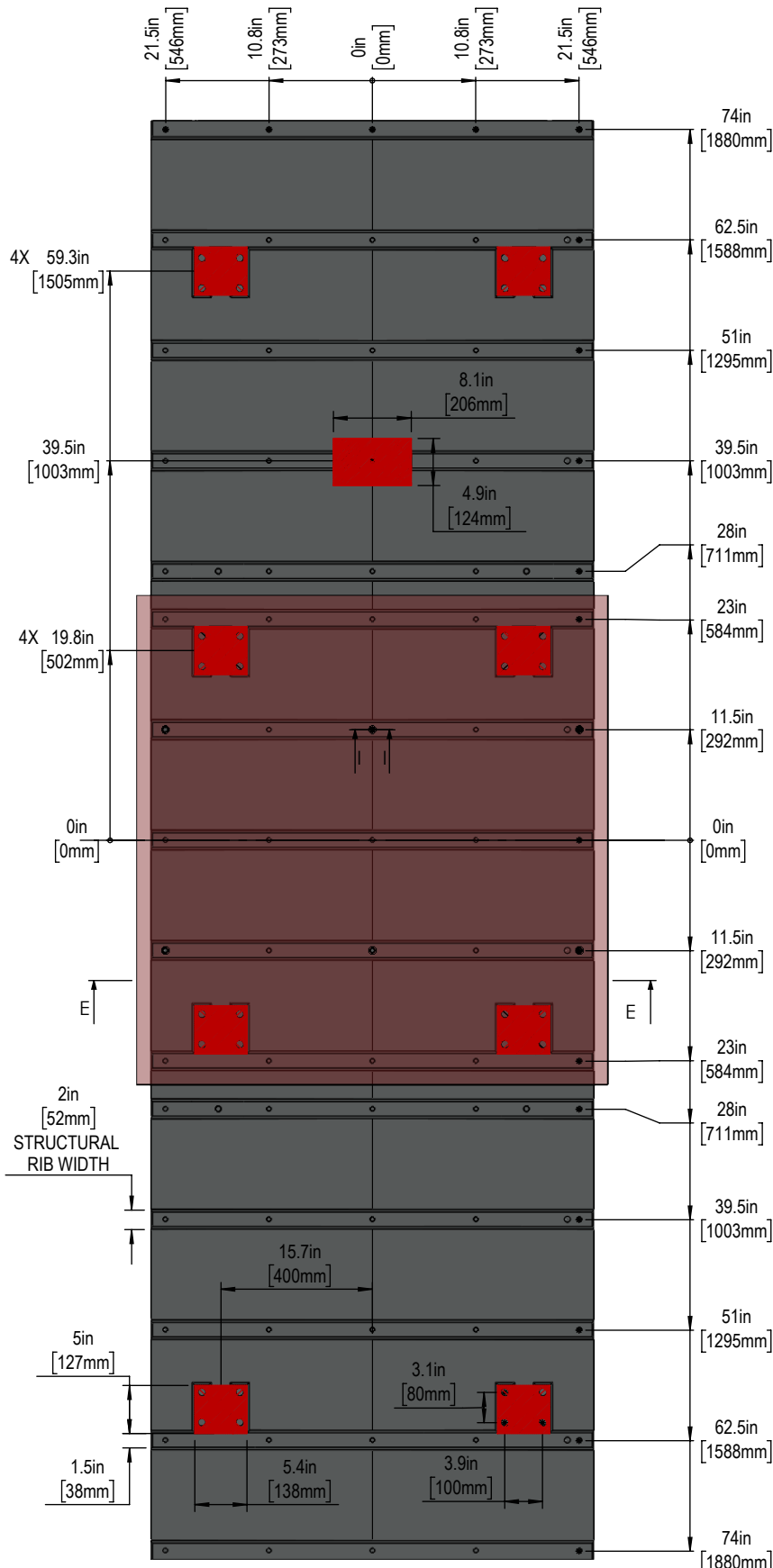

SECTION E-E

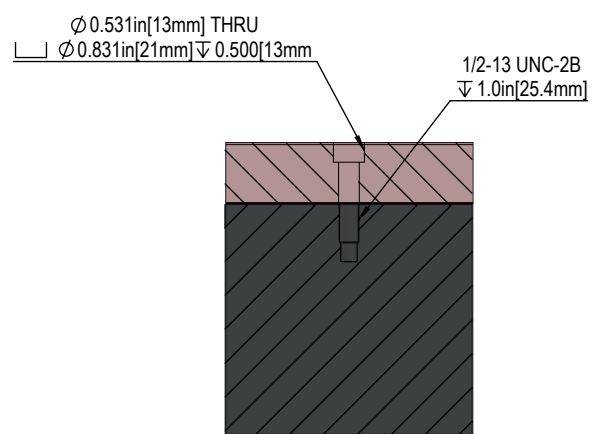

SECTION I-I

NOTE:  
 1. FIXTURE DRILLING MUST NOT EXCEED 1.5in [38.1mm] DUE TO STRUCTURAL RIB CLEARANCE. EXCEEDING THIS LIMIT MAY RESULT IN DAMAGE TO THE TABLE.  
 2. AVOID CUTTING IN AREAS WHERE STRUCTURAL RIBS AND BOLT FIXTURE THREADS ARE FOUND.  
 3. IMAGE SHOWN WITH THE STANDARD TOOLING PLATE