

Total weight of the Single Pneumatic Gripper:  
About 7.5lbs [3.4kg]

Theoretical Maximum Part Weight:  
About 14.5lbs [6.6kg]\*

Minimum Part Diameter:  $\varnothing 0.625$  in [15.7mm]\*  
Maximum Part Diameter:  $\varnothing 6.0$  in [152.3mm]\*

Stroke:  $\varnothing 0.787$  in [20.0mm]

Holding Force:

- 200.08 lbs [890.0 N] (Open)
- 180.50 lbs [803.0 N] (Closed)

Pressure Range:

- 21.8 - 101.5 PSI [0.15 - 0.7 MPa]

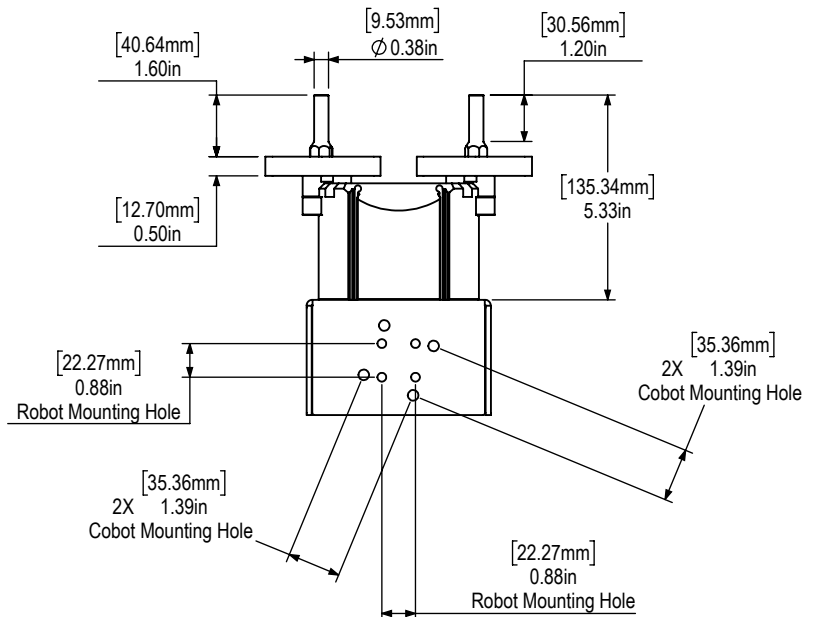
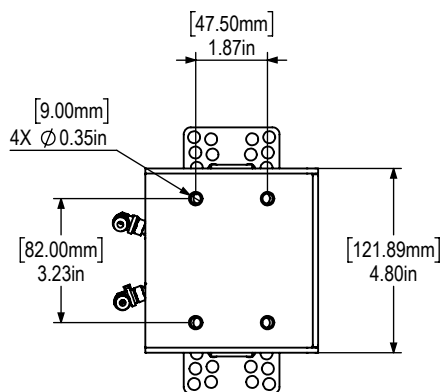
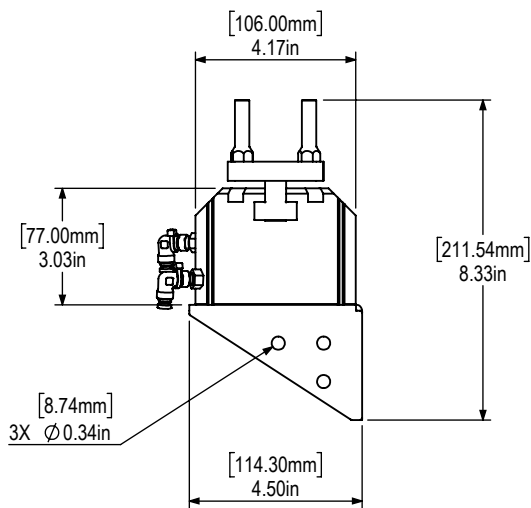
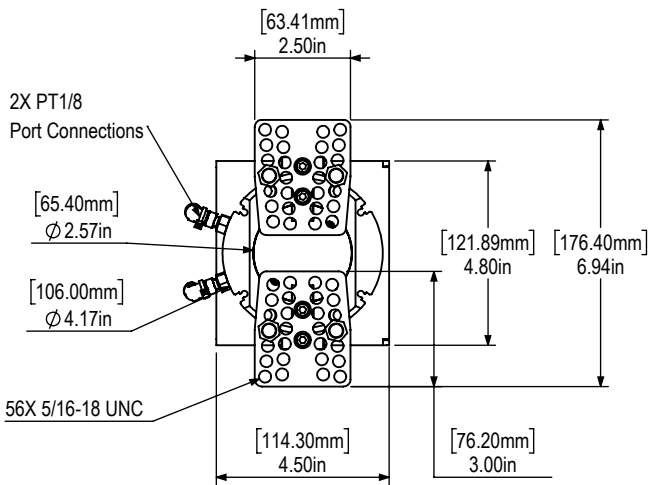

\*Weight varies for each set up. Test weight of part before usage

\*See Page 3 for more information on max part size

## ROUND STOCK

Slug Grippers (Inch)		
Position	Min Ø	Max Ø
1	0.62	1.29
2	1.39	1.88
3	1.33	2.07
4	1.93	2.55
5	2.10	2.85
6	2.60	3.27
7	2.88	3.65
8	3.31	4.02
9	3.67	4.44
10	4.06	4.79
11	4.46	5.24
12	4.82	5.56
13	5.26	6.03
14	5.59	6.34

Slug Grippers (mm)		
Position	Min Ø	Max Ø
1	15.69	32.88
2	35.19	47.67
3	33.82	52.53
4	49.07	64.73
5	53.31	72.51
6	65.92	83.12
7	73.20	92.62
8	84.16	102.17
9	93.25	112.80
10	103.11	121.61
11	113.40	133.03
12	122.47	141.28
13	133.59	153.27
14	142.08	161.10

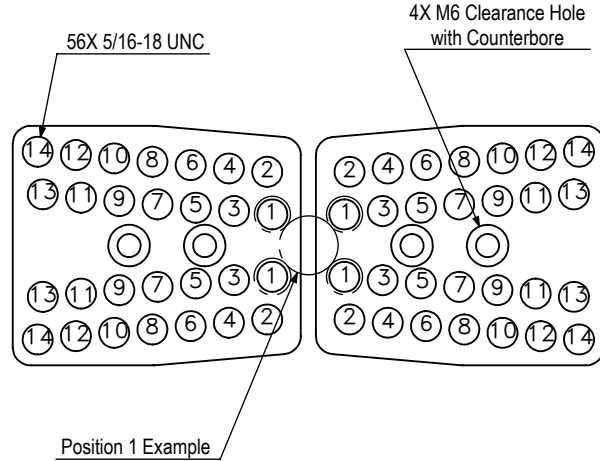

## SHAFT STOCK

Gripper Finger Range (Inch)				
Position	Lower Opening		Upper Opening	
	Min Ø	Max Ø	Min Ø	Max Ø
1	0.86	1.58	1.20	1.88
2	1.43	2.19	1.74	2.42
3	2.03	2.81	2.28	2.96
4	2.65	3.43	2.84	3.58
5	3.26	4.05	3.42	4.18

Gripper Finger Range (mm)				
Position	Lower Opening		Upper Opening	
	Min Ø	Max Ø	Min Ø	Max Ø
1	21.76	40.25	30.46	47.78
2	36.30	55.67	44.21	61.53
3	51.64	71.29	57.95	75.28
4	67.22	87.01	72.19	90.90
5	82.92	102.77	86.99	106.09

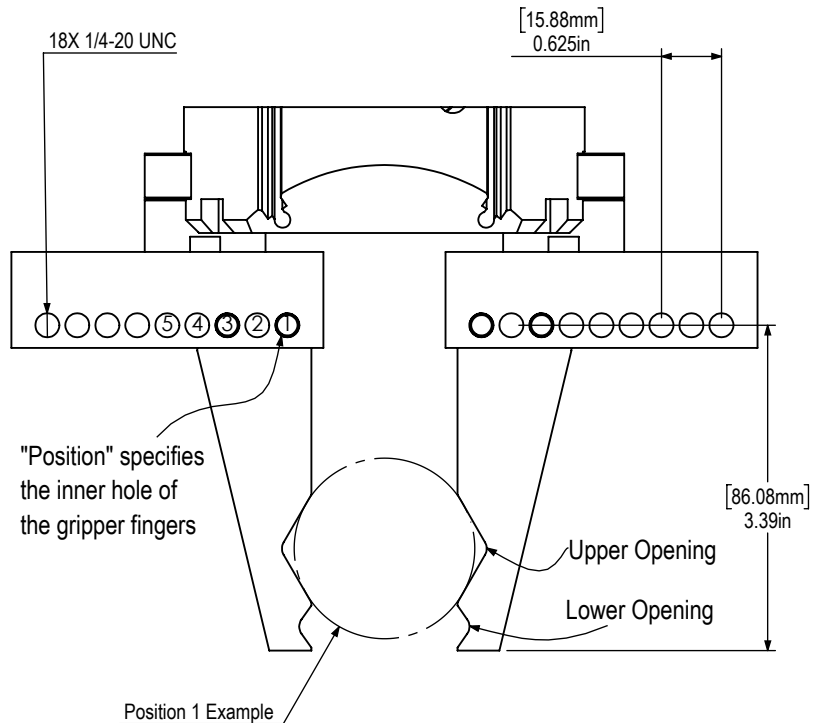

## Slug Maximum Part Size\*

"H" ≤	5.0 in [127.0 mm]
"D" ≤	6.0 in [152.3 mm]
Weight*	< 14.5 lbs [6.6 kg]

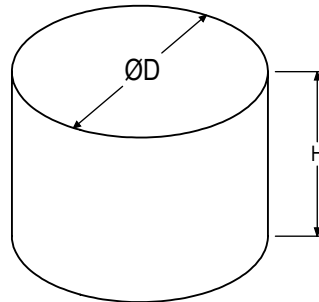

\*Part size is based on theoretical values. Test each part before usage

\*Weight cannot surpass specified value

## Shaft Stock Max Part Size\*

"L" ≤	16.0 in [406.4 mm]*
"D" ≤	4.0 in [90.9 mm]
Weight*	< 14.5 lbs [6.6 kg]

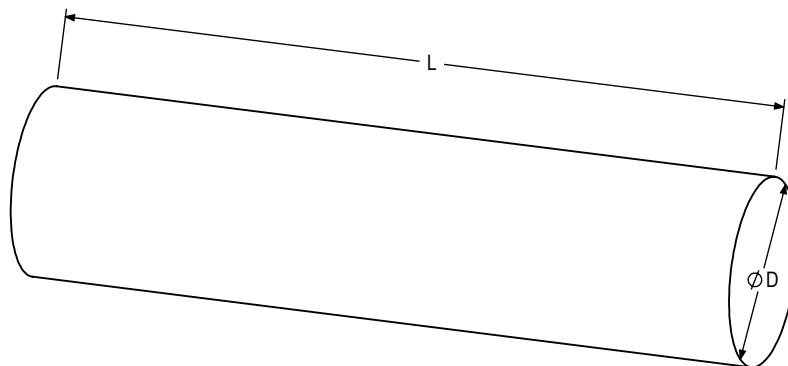

\*Part size is based on theoretical values. Test each part before usage

\*Weight cannot surpass specified value

\*Part length depends on work envelope. Verify part length fits within work envelope