

TOTAL WEIGHT OF 09-0740:

- ABOUT 4.19 LBS [1.9 KG]

THEORETICAL MAXIMUM PART WEIGHT:

- ABOUT 6.8 LBS [3.1 KG]

ROUND STOCK

- MINIMUM PART DIAMETER: \varnothing 0.6 in [15.24 mm]*
- MAXIMUM PART DIAMETER: \varnothing 5.5 in [139.7 mm]*

SQUARE STOCK

- MINIMUM PART WIDTH: 0.375 in [9.53 mm]*
- MAXIMUM PART WIDTH: 5.0 in [127.0 mm]*

STROKE:

- \varnothing 0.472 in [12.0 mm]

HOLDING FORCE:

- 62.0 lbs [280.0 N]

PRESSURE RANGE:

- 43.5 - 101.5 PSI [0.3 - 0.7 MPa]

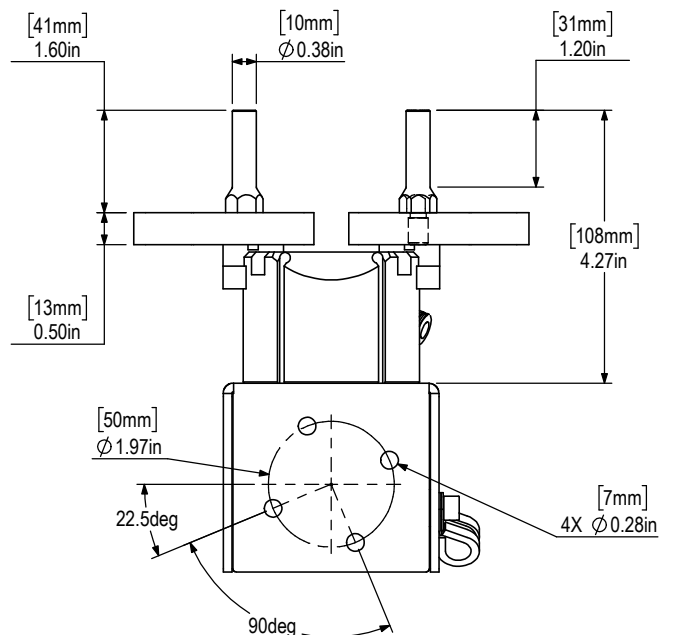

*WEIGHT VARIES FOR EACH SET UP. TEST WEIGHT OF PART BEFORE USAGE.

*SEE PAGE 3 FOR MORE INFORMATION ON MAX PART SIZE



ROUND STOCK

GRIPPERS (INCH)		
Position	Min Ø	Max Ø
1	0.52	0.91
2	1.26	1.69
3	1.51	1.81
4	2.03	2.48
5	2.14	2.50
6	2.82	3.27
7	2.84	3.24
8	3.58	3.99
9	3.62	4.07
10	4.34	4.77
11	4.41	4.87
12	5.11	5.54

GRIPPERS (MM)		
Position	Min Ø	Max Ø
1	13.28	23.20
2	31.94	42.92
3	38.36	46.01
4	51.67	62.97
5	54.23	63.52
6	71.69	83.14
7	72.10	82.20
8	90.90	101.46
9	91.83	103.37
10	110.20	121.04
11	112.03	123.62
12	129.79	140.81

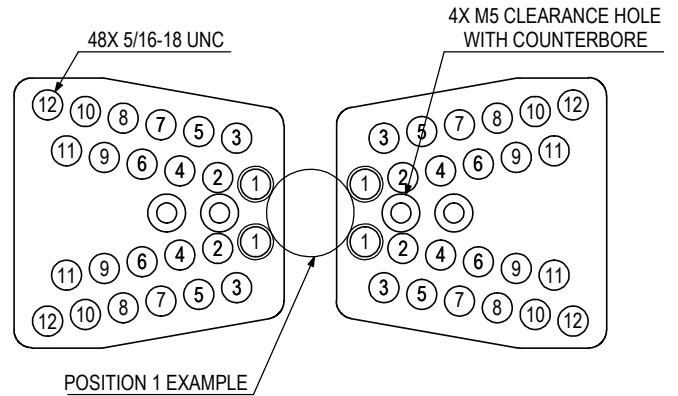

SQUARE STOCK

GRIPPERS (INCH)		
Position	Min Ø	Max Ø
1	0.29	0.77
2	0.69	1.16
3	1.08	1.55
4	1.47	1.95
5	1.87	2.34
6	2.26	2.74
7	2.66	3.13
8	3.05	3.52
9	3.44	3.92
10	3.84	4.31

GRIPPERS (MM)		
Position	Min Ø	Max Ø
1	7.44	19.44
2	17.44	29.44
3	27.45	39.45
4	37.45	49.45
5	47.46	59.46
6	57.47	69.47
7	67.47	79.47
8	77.48	89.48
9	87.48	99.48
10	97.49	109.49

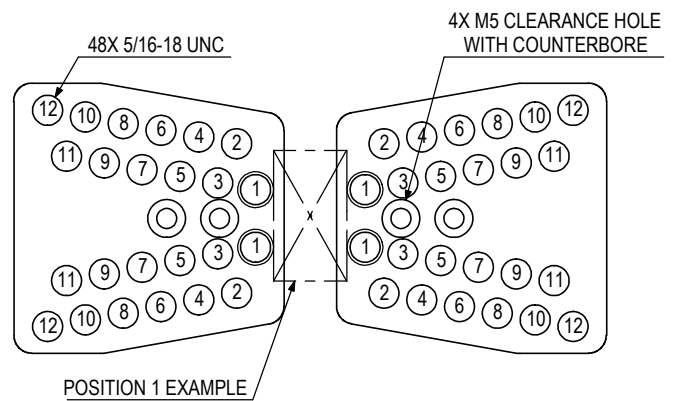

ROUND STOCK MAX PART SIZE

"H" ≤	5.0 in [127.0 mm]
"D" ≤	3.5 in [152.3 mm]
Weight*	< 6.3 lbs [2.9 kg]

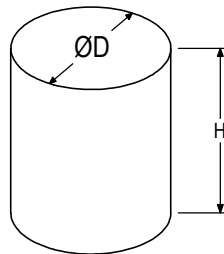

*PART SIZE IS BASED ON THEORETICAL VALUES. TEST EACH PART BEFORE USAGE

*WEIGHT CANNOT SURPASS SPECIFIED VALUE.

SQUARE STOCK MAX PART SIZE

"L" ≤	4.0 in [101.6 mm]
"W" ≤	4.0 in [76.2 mm]
"H" ≤	4.0 in [101.6 mm]
WEIGHT*	< 6.3 lbs [2.9 kg]

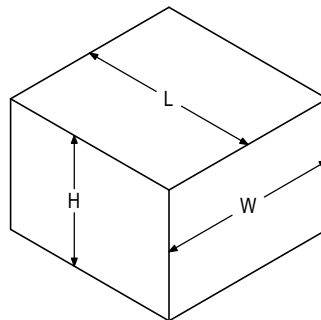

*PART SIZE IS BASED ON THEORETICAL VALUES. TEST EACH PART BEFORE USAGE

*WEIGHT CANNOT SURPASS SPECIFIED VALUE.