



MICS3-AAAZ40AZ1P01

microScan3

SAFETY LASER SCANNERS

SICK
Sensor Intelligence.



Illustration may differ

Ordering information

Integration in the control system	Sub product family	Protective field range	Number of fields	Number of monitoring cases	Connection type	Type	Part no.
Local inputs and outputs (I/O)	microScan3 Core I/O	4 m	8	2	M12	MICS3-AAAZ40AZ1P01	1075842

Other models and accessories → www.sick.com/microScan3



Detailed technical data

Features

Model	Sensor including system plug
Application	Indoor
Protective field range	4 m
Warning field range	40 m
Number of simultaneously monitored fields	≤ 4 ^{1) 2)}
Number of fields	8 ³⁾
Number of monitoring cases	2
Scanning angle	275°
Resolution (can be configured)	30 mm 40 mm 50 mm 70 mm 150 mm 200 mm
Angular resolution	0.39°
Response time	≥ 70 ms
Protective field supplement	65 mm

¹⁾ Protection, warning or contour detection fields.

²⁾ Please note the number of available OSSD pairs.

³⁾ Please note the number of available inputs and OSSD pairs.

Safety-related parameters

Type	Type 3 (IEC 61496)
Safety integrity level	SIL2 (IEC 61508)
Category	Category 3 (EN ISO 13849)
Performance level	PL d (EN ISO 13849)

PFH_D (mean probability of a dangerous failure per hour)	8.0 x 10 ⁻⁸
T_M (mission time)	20 years (EN ISO 13849)
Safe state in the event of a fault	At least one OSSD is in the OFF state.

Functions

Restart interlock	✓
External device monitoring (EDM)	✓
Multiple sampling	✓
Monitoring case switching	✓
Simultaneous monitoring	✓
Static protective field switching	✓
Safe contour detection	✓
Contour as a reference	✓
Integrated configuration memory	✓
Measured data output	None

Interfaces

Connection type	Male connector, M12, 8 pin, A-coded (common male connector for power supply and inputs and outputs)
Universal I/Os	3
Outputs	1
OSSD pairs	
Configuration method	PC with Safety Designer (Configuration and Diagnostic Software)
Configuration and diagnostics interface	USB 2.0, Mini-USB
Display elements	Graphic color display, LEDs

Electrical data

Protection class	III (EN 61140)
Supply voltage V_s	24 V DC (16.8 V DC ... 30 V DC)
Power consumption	7 W (without output load)

Mechanical data

Dimensions (W x H x D)	112 mm x 135.1 mm x 111.1 mm
Weight	1.15 kg
Housing material	Aluminum
Housing color	RAL 1021 (yellow), RAL 9005 (black)
Optics cover material	Polycarbonate
Optics cover surface finish	Outside with scratch-resistant coating

Ambient data

Enclosure rating	IP65 (IEC 60529)
Ambient light immunity	≤ 3,000 lx (IEC 61496-3)
Ambient operating temperature	-10 °C ... +50 °C
Storage temperature	-25 °C ... +70 °C

Vibration resistance		IEC 60068-2-6, IEC 60068-2-64, IEC 60721-3-5, IEC TR 60721-4-3, IEC 61496-1, IEC 61496-3
	Class	5M1 (IEC 60721-3-5) 3M4 (IEC TR 60721-4-3)
Shock resistance		IEC 60068-2-27, IEC 60721-3-5, IEC TR 60721-4-3, IEC 61496-1, IEC 61496-3
	Class	5M1 (IEC 60721-3-5) 3M4 (IEC TR 60721-4-3)
	Continuous shock	100 m/s ² , 16 ms 150 m/s ² , 6 ms
EMC		IEC 61496-1 IEC 61000-6-2 IEC 61000-6-4

Other information

Type of light	Pulsed laser diode
Wave length	845 nm
Detectable remission factor	1.8% to several 1000%
Laser class	1M (21 CFR 1040.10 and 1040.11, IEC 60825-1)

Classifications

eCl@ss 5.0	27272705
eCl@ss 5.1.4	27272705
eCl@ss 6.0	27272705
eCl@ss 6.2	27272705
eCl@ss 7.0	27272705
eCl@ss 8.0	27272705
eCl@ss 8.1	27272705
eCl@ss 9.0	27272705
eCl@ss 10.0	27272705
eCl@ss 11.0	27272705
eCl@ss 12.0	27272705
ETIM 5.0	EC002550
ETIM 6.0	EC002550
ETIM 7.0	EC002550
ETIM 8.0	EC002550
UNSPSC 16.0901	39121528

Dimensional drawing (Dimensions in mm (inch))

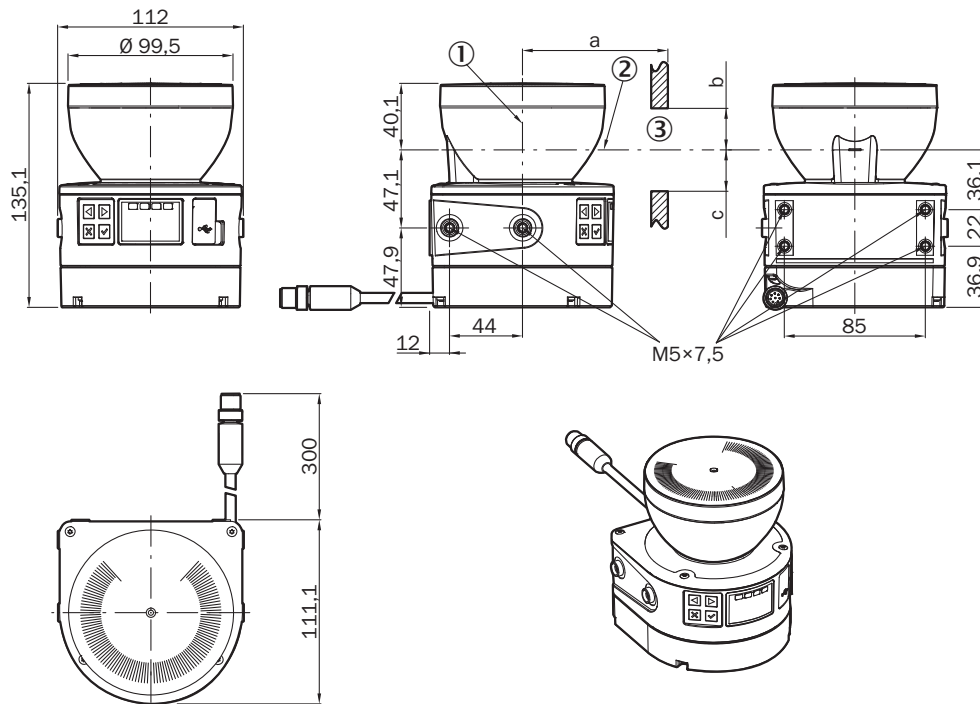

- ① Mirror axis of rotation
- ② Scan plane
- ③ Required viewing slit (a: length of the viewing slit, b: minimum height above the scan plane, c: minimum height below the scan plane. See the operating instructions for details.)

Pin assignment

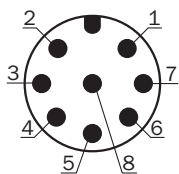

Pin	Designation	Description
1	+24 V DC	Supply voltage +24 V DC
2	OSSD 1.A	OSSD pair 1, OSSD A
3	0 V DC	Supply voltage 0 V DC
4	OSSD 1.B	OSSD pair 1, OSSD B
5	Uni-I/O 1	Universal I/O 1, configurable
6	Uni-I/O 2	Universal I/O 2, configurable
7	Uni-I/O 3	Universal I/O 3, configurable
8	FE	Functional earth/shielding

For details see operating instructions

Connection diagram

microScan3 Core I/O with restart interlock and external device monitoring at RLY3-OSSD1 safety relay

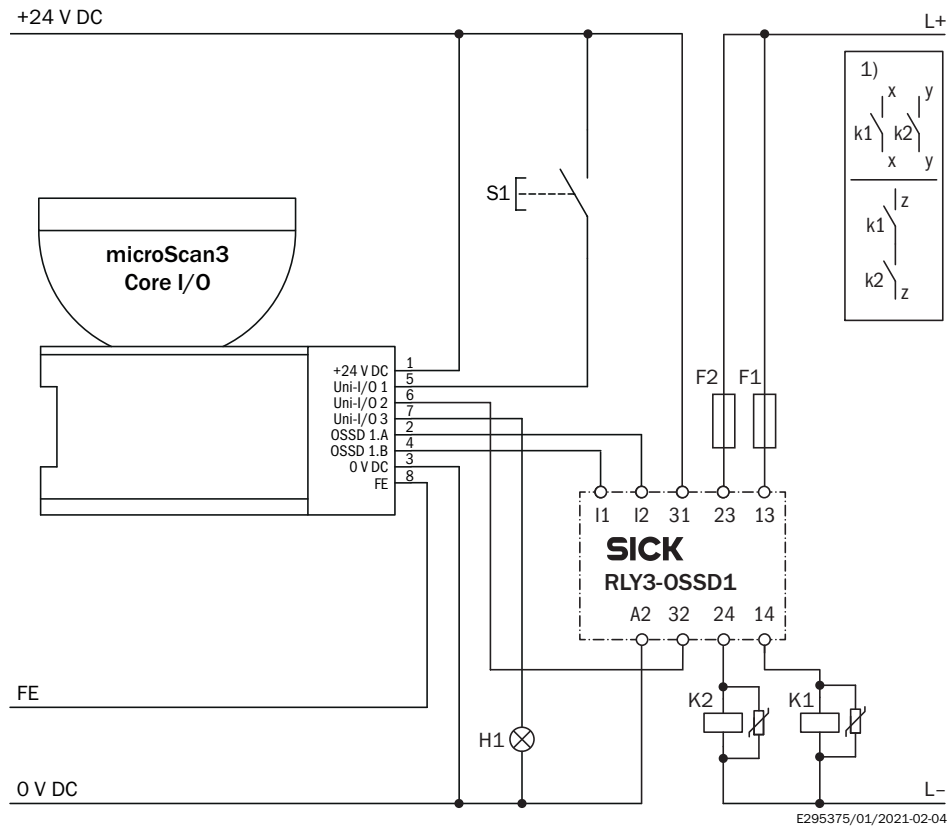

ⓘ Output circuits: These contacts must be incorporated into the control such that the dangerous state is brought to an end if the output circuit is open. For categories 4 and 3, they must be incorporated on dual-channels (x, y paths). Single-channel incorporation into the control (z path) is only possible with a single-channel control and taking the risk analysis into account.

Uni-I/O 1: configured as input reset

Uni-I/O 2: configured as input external device monitoring (EDM)

Uni-I/O 3: configured as output reset required

microScan3 Core I/O with restart interlock and external device monitoring

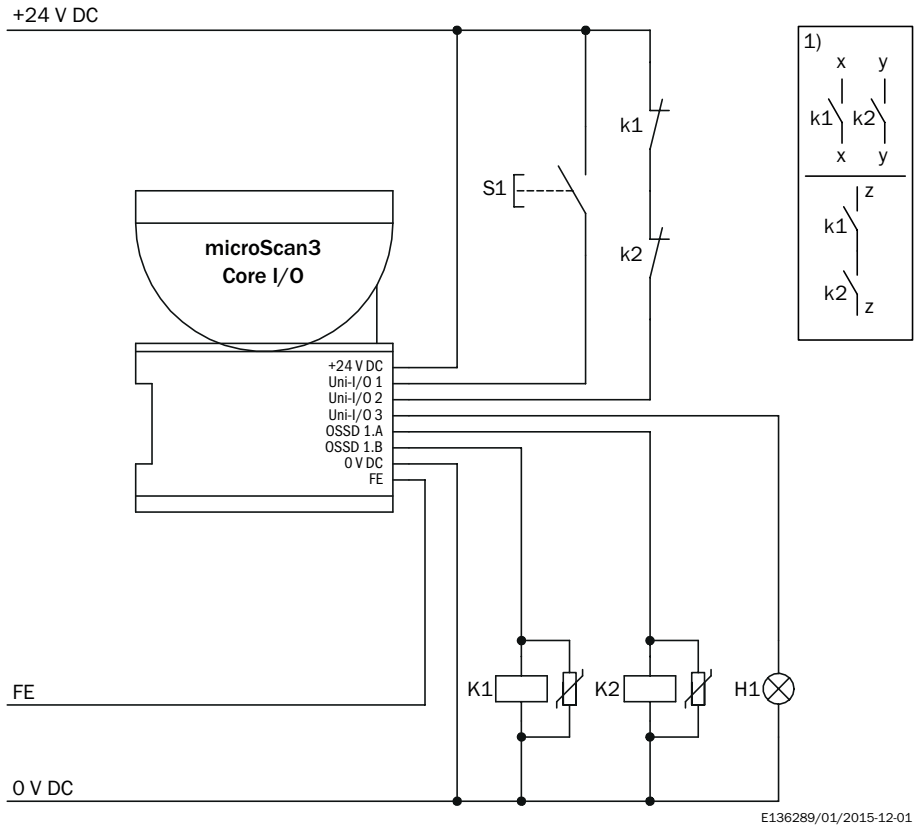

E136289/01/2015-12-01





① Output circuits: These contacts must be incorporated into the control such that the dangerous state is brought to an end if the output circuit is open. For categories 4 and 3, they must be incorporated on dual-channels (x, y paths). Single-channel incorporation into the control (z path) is only possible with a single-channel control and taking the risk analysis into account.

- Uni-I/O 1: configured as input reset
- Uni-I/O 2: configured as input external device monitoring (EDM)
- Uni-I/O 3: configured as output reset required

Recommended accessories

Other models and accessories → www.sick.com/microScan3

	Brief description	Type	Part no.
Mounting brackets and plates			
	1 piece, mounting bracket, heavy-duty version, with protection cover, for floor mounting, height adjustment possible from 90 ... 310 mm, scanner tilt angle: ± 5°. Additional mounting brackets are not required. ¹⁾ steel, painted (RAL 1021)	Heavy-duty mounting kit for floor mounting	2102289
	1 piece, mounting bracket 150 mm for floor mounting of microScan3, stainless steel, Bracket and 4 x M5 screws for attaching the microScan3	Mounting bracket 150 mm for floor mounting of microScan3	2112950
	1 piece, mounting bracket 300 mm for floor mounting of microScan3, stainless steel, Bracket and 4 x M5 screws for attaching the microScan3	Mounting bracket 300 mm for floor mounting of microScan3	2112951

	Brief description	Type	Part no.
	1 piece, mounting bracket, Stainless steel V2A (1.4301), powder-coated IGP-DURA face 5803A	Mounting kit 1a	2073851
	1 piece, mounting bracket with protection of optics hood, Stainless steel V2A (1.4301), powder-coated IGP-DURA face 5803A	Mounting kit 1b	2074242
	1 piece, alignment bracket, alignment with cross-wise axis and depth axis possible, distance between mounting surface and device: 22.3 mm, only in conjunction with mounting kit 1a (2073851) or 1b (2074242), Stainless steel V2A (1.4301), powder-coated IGP-DURA face 5803A	Mounting kit 2a	2073852
Plug connectors and cables			
	Head A: female connector, M12, 8-pin, straight, A-coded Head B: Flying leads Cable: Sensor/actuator cable, PUR, halogen-free, unshielded, 2 m	DOL-1208G02MD25KM1	2079314
	Head A: female connector, M12, 8-pin, straight, A-coded Head B: Flying leads Cable: Sensor/actuator cable, PUR, halogen-free, unshielded, 5 m	DOL-1208G05MD25KM1	2079315
	Head A: female connector, M12, 8-pin, straight, A-coded Head B: Flying leads Cable: Sensor/actuator cable, PUR, halogen-free, unshielded, 10 m	DOL-1208G10MD25KM1	2079316
	Head A: female connector, M12, 8-pin, straight, A-coded Head B: Flying leads Cable: Sensor/actuator cable, PUR, halogen-free, unshielded, 20 m	DOL-1208G20MD25KM1	2092105
	Head A: female connector, M12, 8-pin, straight, A-coded Head B: Flying leads Cable: Sensor/actuator cable, PUR, halogen-free, unshielded, 30 m	DOL-1208G30MD25KM1	2092106
	Head A: male connector, USB-A, straight Head B: male connector, Mini-USB, straight Cable: USB, shielded, 3 m For connecting the configuration connection to the USB interface on the PC	Connection cable (male connector-male connector)	6042517
	Head A: male connector, USB-A, straight Head B: male connector, Mini-USB, straight Cable: USB, shielded, 5 m For connecting the configuration connection to the USB interface on the PC		6053566

SICK AT A GLANCE

SICK is one of the leading manufacturers of intelligent sensors and sensor solutions for industrial applications. A unique range of products and services creates the perfect basis for controlling processes securely and efficiently, protecting individuals from accidents and preventing damage to the environment.

We have extensive experience in a wide range of industries and understand their processes and requirements. With intelligent sensors, we can deliver exactly what our customers need. In application centers in Europe, Asia and North America, system solutions are tested and optimized in accordance with customer specifications. All this makes us a reliable supplier and development partner.

Comprehensive services complete our offering: SICK LifeTime Services provide support throughout the machine life cycle and ensure safety and productivity.

For us, that is “Sensor Intelligence.”

WORLDWIDE PRESENCE:

Contacts and other locations –www.sick.com