

COLLAPSED VIEW

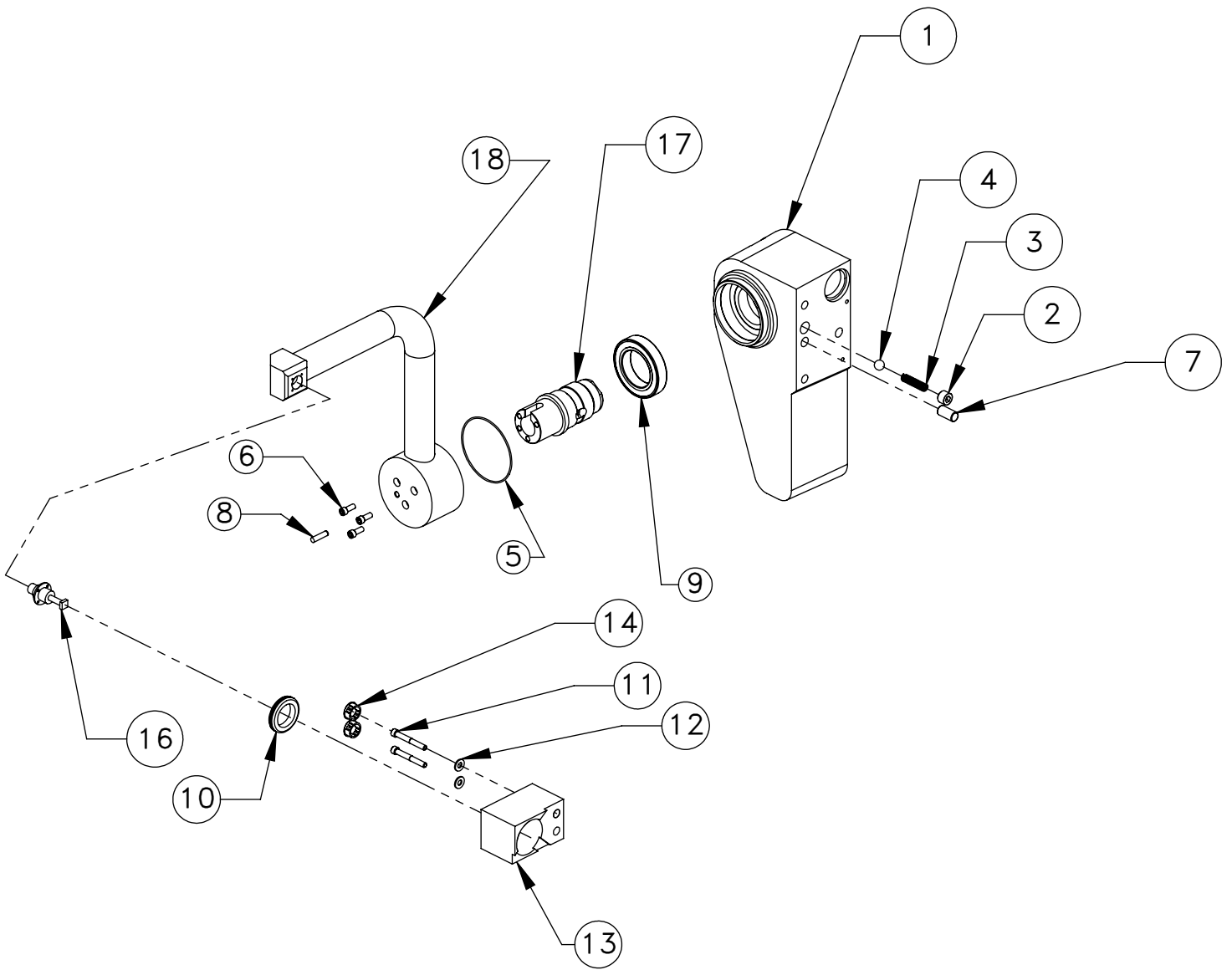

BACK VIEW

ITEM NO.	DESCRIPTION	QTY
1	LTP PIVOT BLOCK MACHINED	1
2	SSS 5/8-11 X 1/2 CUP PT MCMASTER 91375A	1
3	SPRING CENTURY D1203	1
4	BALL 1/2 HIGH PRECISION S30	1
5	O-RING 2-043 BUNA	1
6	SHCS 1/4-20 X 5/8 ZINC PLATED	3
7	DWOEL PIN 1/2 X 1	1
8	DOWEL PIN 1/4 X 1 PULL W/8-32 NC 2-B	1
9	BEARING DEEP GROOVE6010ZZW/NON-METALLIC	1
10	GROMMET 1-7/8	1
11	SHCS 1/4-20 X 2	2
12	WASHER 1/4 FLAT A325 ZINC-PLATED	2
13	LTP HOME COVER	1
14	PLUG HOLE .813 DIA BLACK	2
15	32-0425 PROBE R-TS20/M-T18 LTP	1
16	PROBE R-TS20/M-T18 LTP	1
17	LTP PIVOT SHAFT	1
18	LTP ARM	1

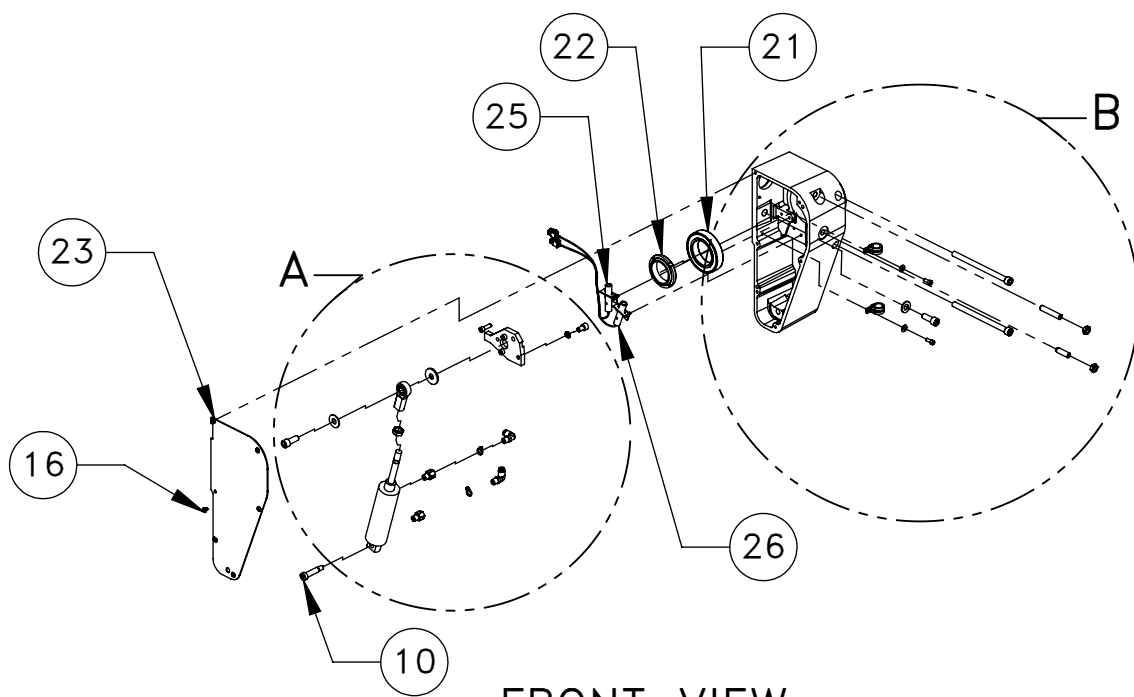

FRONT VIEW

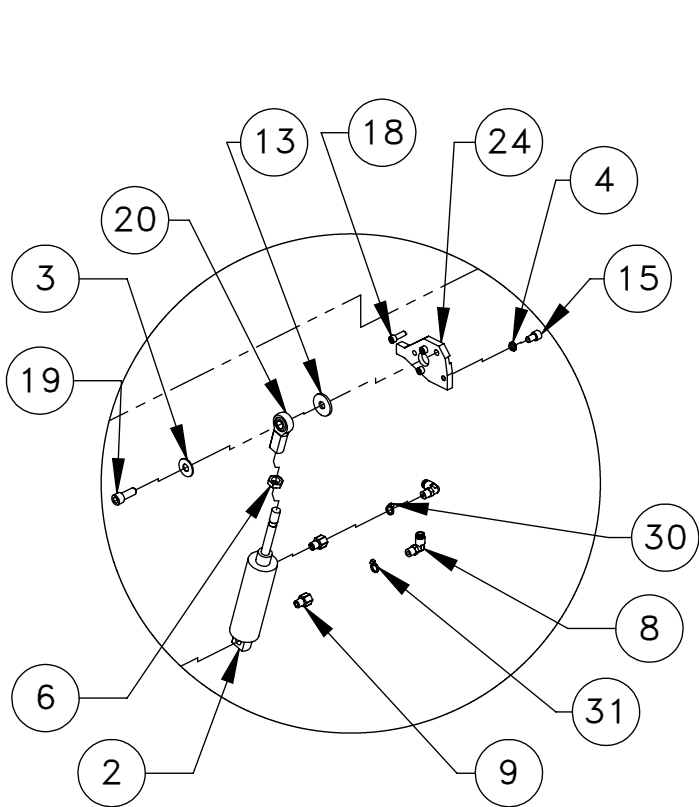

DETAIL A
SCALE 1 : 10

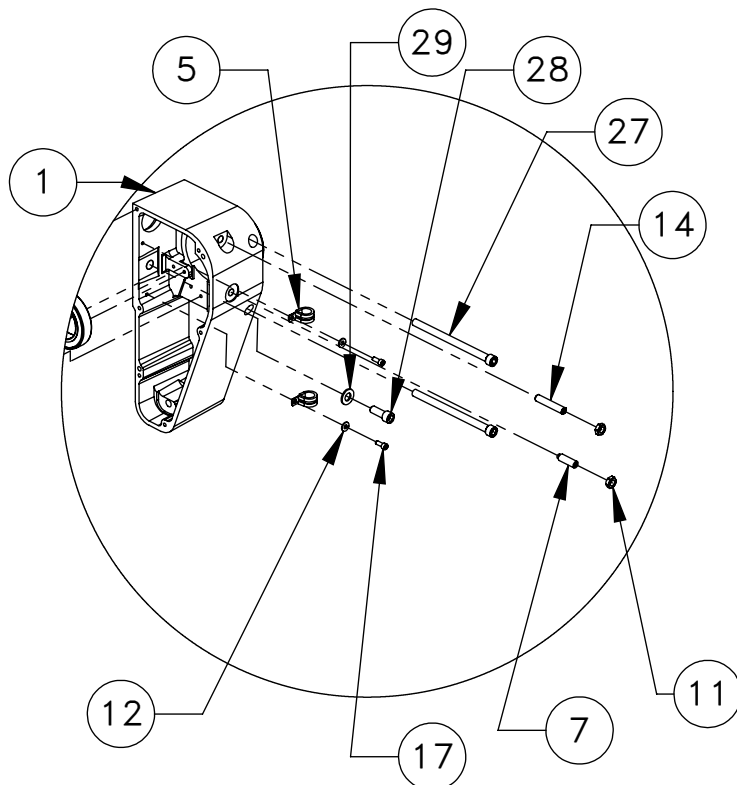

DETAIL B
SCALE 1 : 10

ITEM NO.	DESCRIPTION	QTY.
1	LTP PIVOT BLOCK MACHINED	1
2	AIR CYL 1.5 X 2	1
3	WASHER 3/8 FLAT USS PLT	1
4	WASHER 5/16 STEEL .010THK X .4380	11
5	CABLE CLAMP 7/16 RICHCO SPN-7	2
6	NUT 7/16-20 JAM	1
7	SSS 3/8-24 X 1 1/4 HALF DOG	1
8	FITG LBO-1/4 X 1/8 NPT M AIR & GREASE	2
9	ORIFICE 1/8NPT X .020 O'KEEFE CONTROLS	2
10	SHLDR BOLT 3/8 X 1 1/4	1
11	NUT 3/8-24 JAM	2
12	WASHER #10 FLAT SAE PLT	2
13	WASHER 3/8 X 1 1/8 OD X 1/8 THK BLK	1
14	SSS 3/8-24 X 2.0 FLAT POINT	1
15	SHCS 5/16-18 X 1/2	1
16	BHCS 10-32 X 1/4	6
17	SHCS 10-32 X 1/2 ZINC PLATED	2
18	SHCS 1/4-20 X 3/4 BLACK OXIDE	3
19	SHCS 3/8-16 X 1 W/BLUE LOCTITE	1
20	ROD END 7/16-20F X 7/16 THRU	1
21	BEARING DEEP GROOVE6010ZZW/NON-METALLIC	1
22	BEARING LOCKNUT BH-09 WHITTET-HIGGINS	1
23	COVER LTP PIVOT BLOCK	1
24	LTP ROTATOR PLATE	1
25	PROX NO PKT DOWN	1
26	PROX NO PKT UP	1
27	SHCS 3/8-16 X 5.50 LG	2
28	SHCS 3/8-16 X 1	1
29	WASHER 3/8 HARD #275-15	1
30	CBL TIE PURPLE 18 LB X 4" LG POLYAMIDE	1
31	CBL TIE GRAY 18 LB X 4" LG POLYAMIDE	1

SHEET 2 OF 3

EFFECTIVE DATE

JAN-2013

SAP DOC NO./VER: 1000006532/01

DESCRIPTION
ST AUTO TOOL PROBE

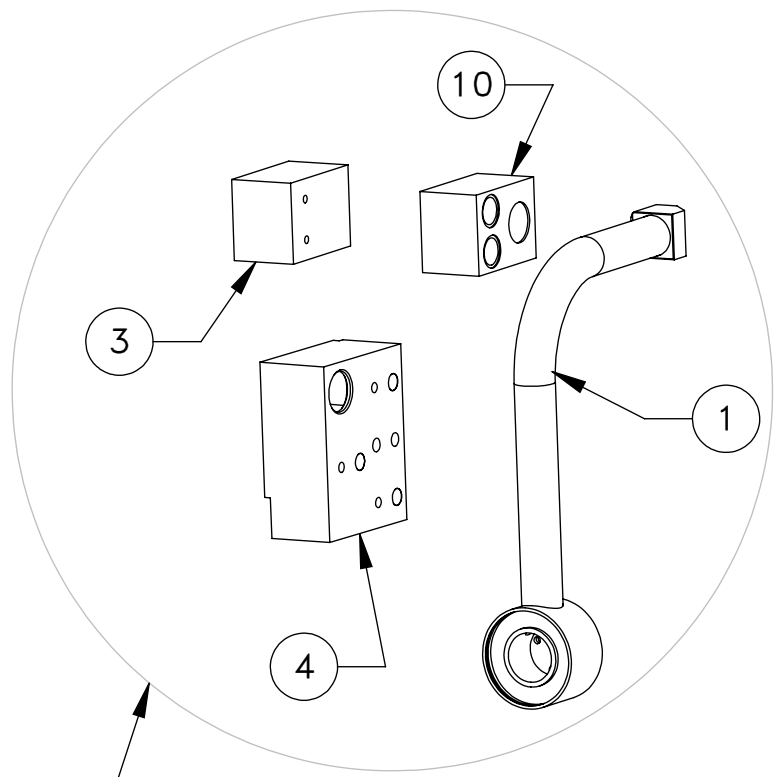

ST 30 BB WITH OPC 15

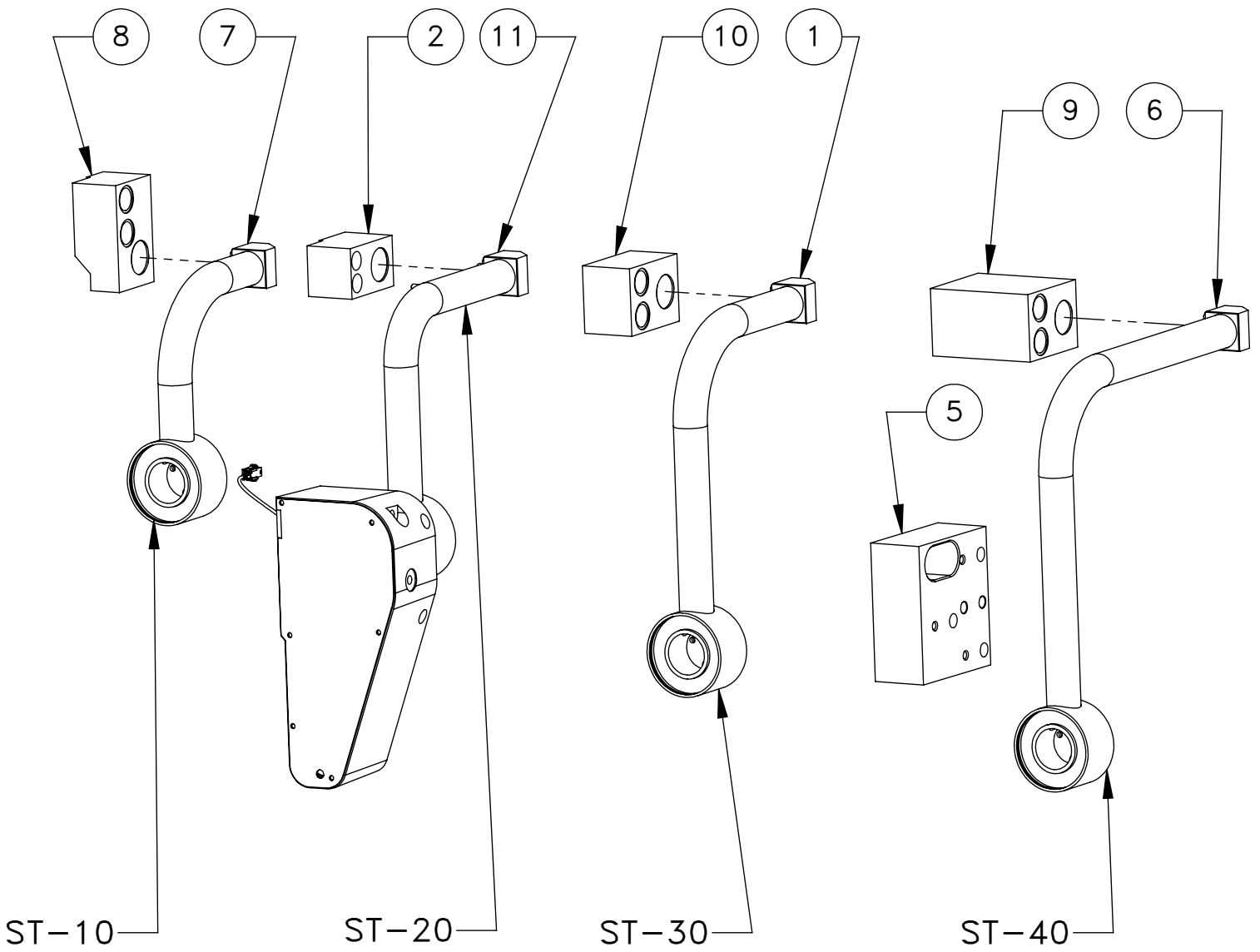

ITEM NO.	DESCRIPTION	QTY.
1	ARM ALTP S30 BB	1
2	LTP HOME COVER	1
3	20-5610A SPACER BB ATP HOME CVR 15 IN CHUCK	1
4	20-5609A BRACKET BB ATP WITH 15	1
5	SPACER ATP ADAPTER 18 IN CHUCK	1
6	ARM ATP 18 IN CHUCK	1
7	LTP ARM ST10	1
8	COVER ALTP HOME ST	1
9	COVER ALTP HOME ST-40 BB	1
10	COVER ALTP HOME S30 BB	1
11	LTP ARM	1