

ITEM NO.	DESCRIPTION	QTY.
1	HOLDING ARM MACHINED VF-3	1
2	TOOL HOLDING ARM GASKET VF-3	1
3	BEARING HOUSING	1
4	HHB 1/2-13 X 3 GRADE 5 PLATED	4
5	COVER WIRE CHANNEL 17 1/8 FOR L	1
6	WASHER, 1/2" ID X .125 THK X 1.125 OD, HARD, BLK OX	4
7	TOOL CARRIAGE GASKET VF-1/3	1
8	SHUTTLE MTR 40T T/C	1
9	WASHER 3/4 FLAT USS PLT	1
10	NUT 3/4-10 NYLON LOCK	1
11	TOOL #1 STANDOFF	1
12	DOWEL PIN 1/4 X 1	1
13	SPACER RING TOOL CHANGER	2
14	RIDER TRAP DOOR	3
15	BEARING LOCKNUT BH-06	1
16	R BRG RAD BALL M15-35-11	2
17	VERTICAL AXLE VF-1	1
18	20 PKT GENEVA STAR 2PIN	1
19	20 POCKET TOOL CHANGER CARRIAGE MACHIN	1
20	20 PCKT TOOL CHANGER CVR 20/PLT	1
21	20 TOOL TRAP DOOR	1
22	GENEVA DRIVE MTR 37RPM 90VDC 74IN LBS	1
23	COVER HOLDING ARM	1
24	DUCT 19 1 X 3	1
25	CONDUIT MTG PLATE VF-3	1
26	COVER TOOL CARRIAGE	1

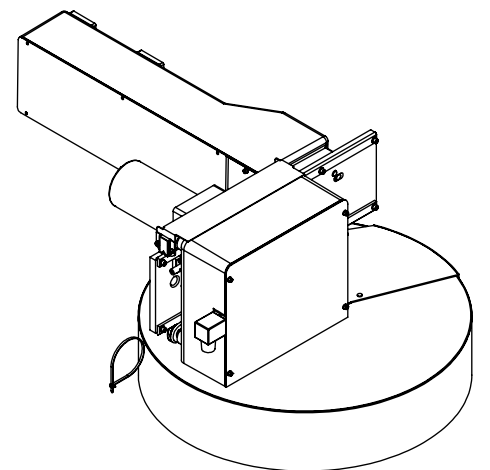

SHEET 1 OF 3

DESCRIPTION

EFFECTIVE DATE

VMC UMBRELLA TOOL CHANGER 20 POCKET

JULY-2009

SAP DOC NO./VER: 1000006520/01

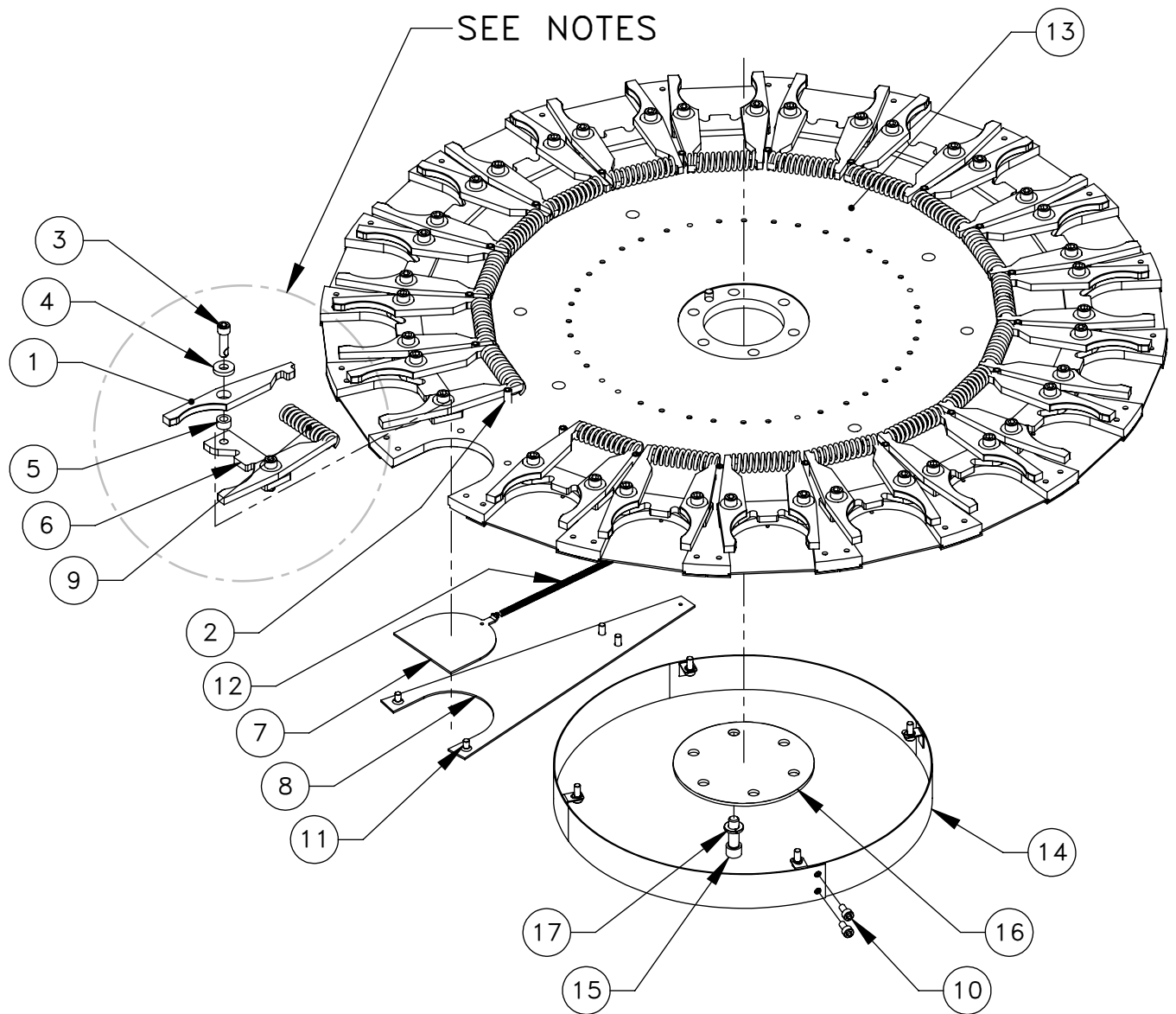

DETAIL A
SCALE 1 : 5

NOTES:

1. COMPONENTS NO.: 1, 3, 4, 5, 6 AND 9 ARE CT CONFIGURATION.
SEE HAAS SERVICE SITE FOR OTHER REFERENCES ON BT CONFIGURATION

ITEN NUMBER	DESCRIPTION	QTY
1	CT EXTRACTOR, CAROUSEL TOOL CHANGER	40
2	ROLL PIN 7/32 X 7/8	20
3	SHCS 1/4-20 X 7/8 W/LOCTITE	40
4	WASHER 1/4 HARD 1/4ID X 5/8OD X 1/8 T	40
5	EXTRACTOR BUSHING	40
6	KEY EXTRACTOR SPRING	20
7	SLIDING PANEL	20
8	20 TOOL SLIDING PNL CVRPIE SHAPED	20
9	SPRING EXTRACTOR HORIZ HS TOOL CHANGER	20
10	SHCS 10-32 X 3/8 W/LOC 2A THREADS ZIN	42
11	FHCS 10-32 X 3/8	40
12	COMPRESSION SPRING T/C DOOR SPRING	20
13	20 TOOL CAROUSEL 0.375 SN6700 & LWR 93	1
14	NUMBER RING TOOL CHANGER 150/PLT	1
15	SHCS 5/16-18 X 1	1
16	CAP TOOL CHANGER	1
17	WASHER 5/16 SPLT LOCK PLT	11

SHEET 2 OF 3

DESCRIPTION

EFFECTIVE DATE

VMC UMBRELLA TOOL CHANGER 20 POCKET

JULY-2009

SAP DOC NO./VER: 1000006520/01

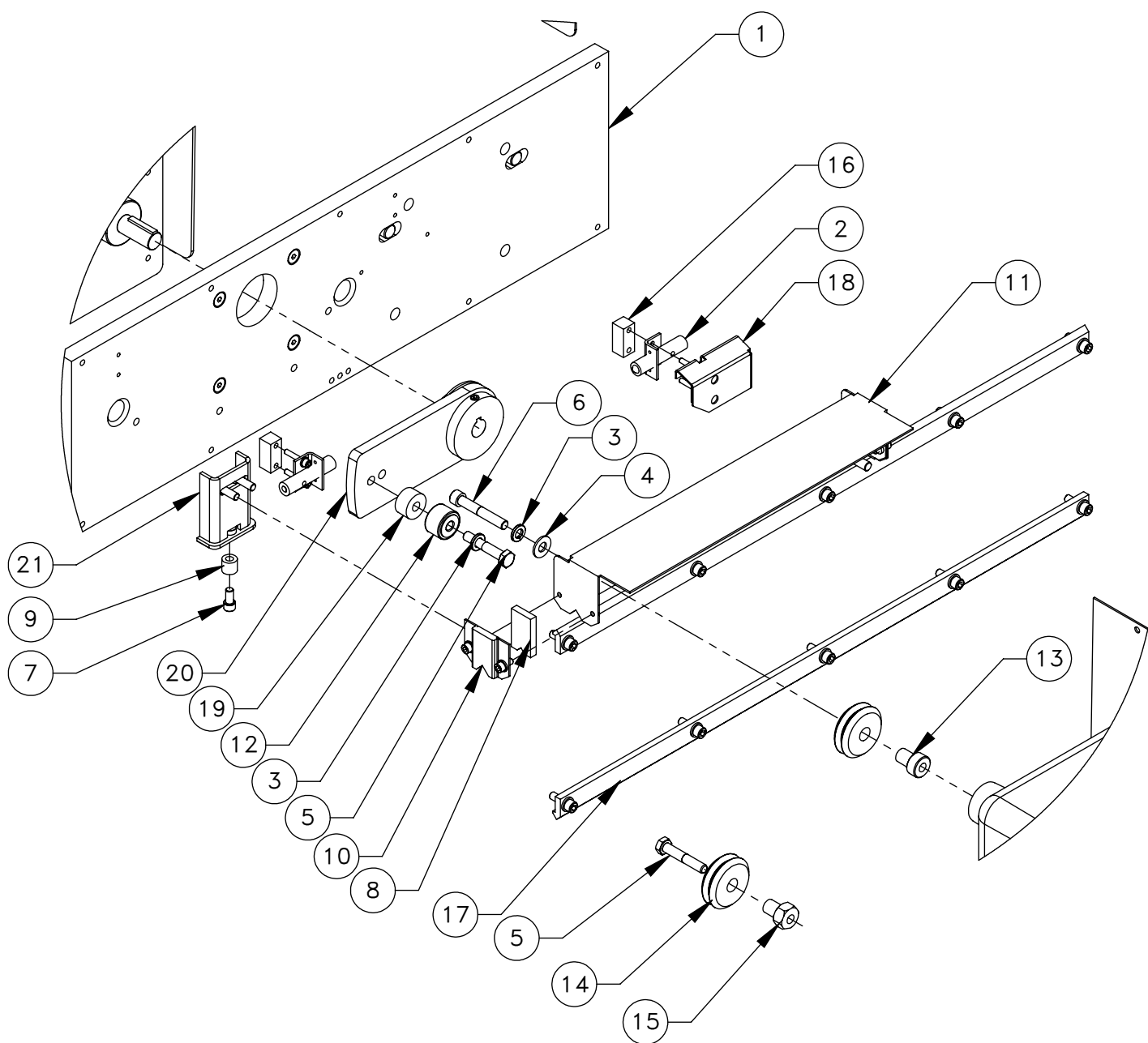

DETAIL B
SCALE 1 : 5

ITEM NUMBER	DESCRIPTION	QTY
1	20 TOOL HOLDING PLATE	1
2	PROX SW NC 2WR 0.6M WITH BRACKET	1
3	WASHER 5/16 SPLT LOCK PLT	12
4	WASHER 5/16 HARD 11/32ID X 3/4OD	4
5	HHB 5/16-18 X 1 3/4 GRADE 8 PLAIN	3
6	SHCS 5/16-18 X 2	2
7	SHCS 1/4-20 X 1/2 ZINC PLATED	1
8	FELT T/C CARRIAGE RAIL WIPER	2
9	LOCATING PIN USES 1/4-20 X 1	1
10	RETAINER T/C FELT	2
11	V-TRACK COVER, VF	1
12	CAM FOLWR 1.00 HOLOW .312 T/C	1
13	STANDARD BUSHING GD WHL T/C ROUND H	2
14	GUIDE WHEEL VF T/C BARRIAGE	4
15	BUSHING, GUIDE WHEEL, HEX HEAD, OFFSET	2
16	BLOCK SWITCH MTG	2
17	V-TRACK TOOL CHANGER	2
18	TOOL CHANGER SWITCH COVER	1
19	SPACER CAM FOLLOWER	1
20	ARM SLIP CLUTH	1
21	BRACKET DOOR OPENER	1

SHEET 3 OF 3

EFFECTIVE DATE

JULY-2009

VMC UMBRELLA TOOL CHANGER 20 POCKET

SAP DOC NO./VER: 1000006520/01