

8X  $\phi$  .16in [4.0mm]  $\nabla$  .49in [12.4mm]  
10-32 UNF - 2B  $\nabla$  .38in [9.7mm]

$\phi$  2.20in [55.9mm]  
Bolt Hole Circle

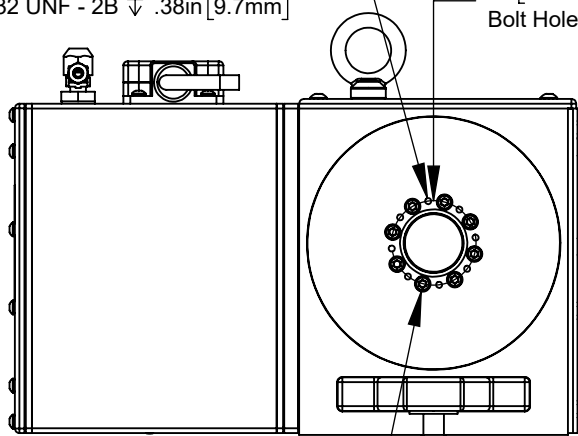

8X  $\phi$  .27in [6.8mm] THRU ALL  
 $\sqsubset$   $\phi$  .41in [10.3mm]  $\nabla$  .26in [6.5mm]

2X  $\phi$  .50in<sup>+0.001</sup>/<sub>-.000</sub> [12.7mm<sup>+0.025</sup>/<sub>0.000</sub>]  $\nabla$  .30in [7.6mm]  
Dowel Pin Holes

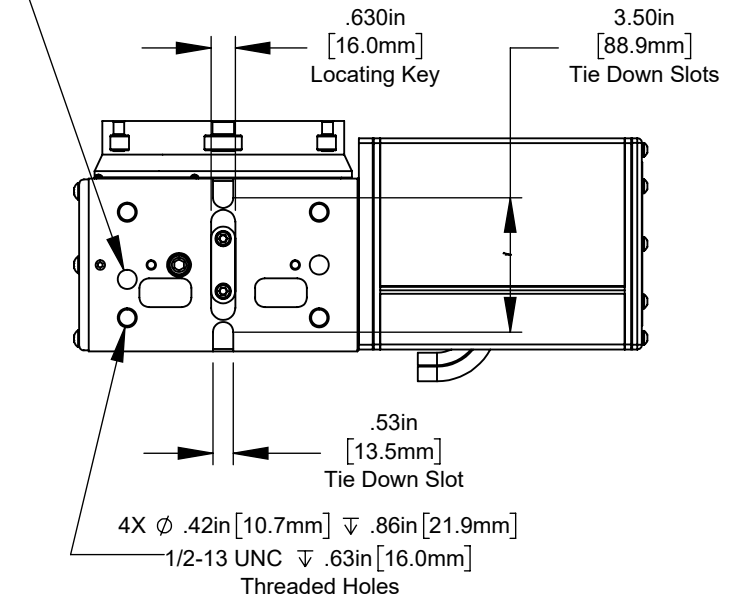

All dimensions based on stackup of sheetmetal, subject to variation of 1/2" ( 13 mm)

\*Due to continual product improvements, machine dimensions are subject to change without notice.

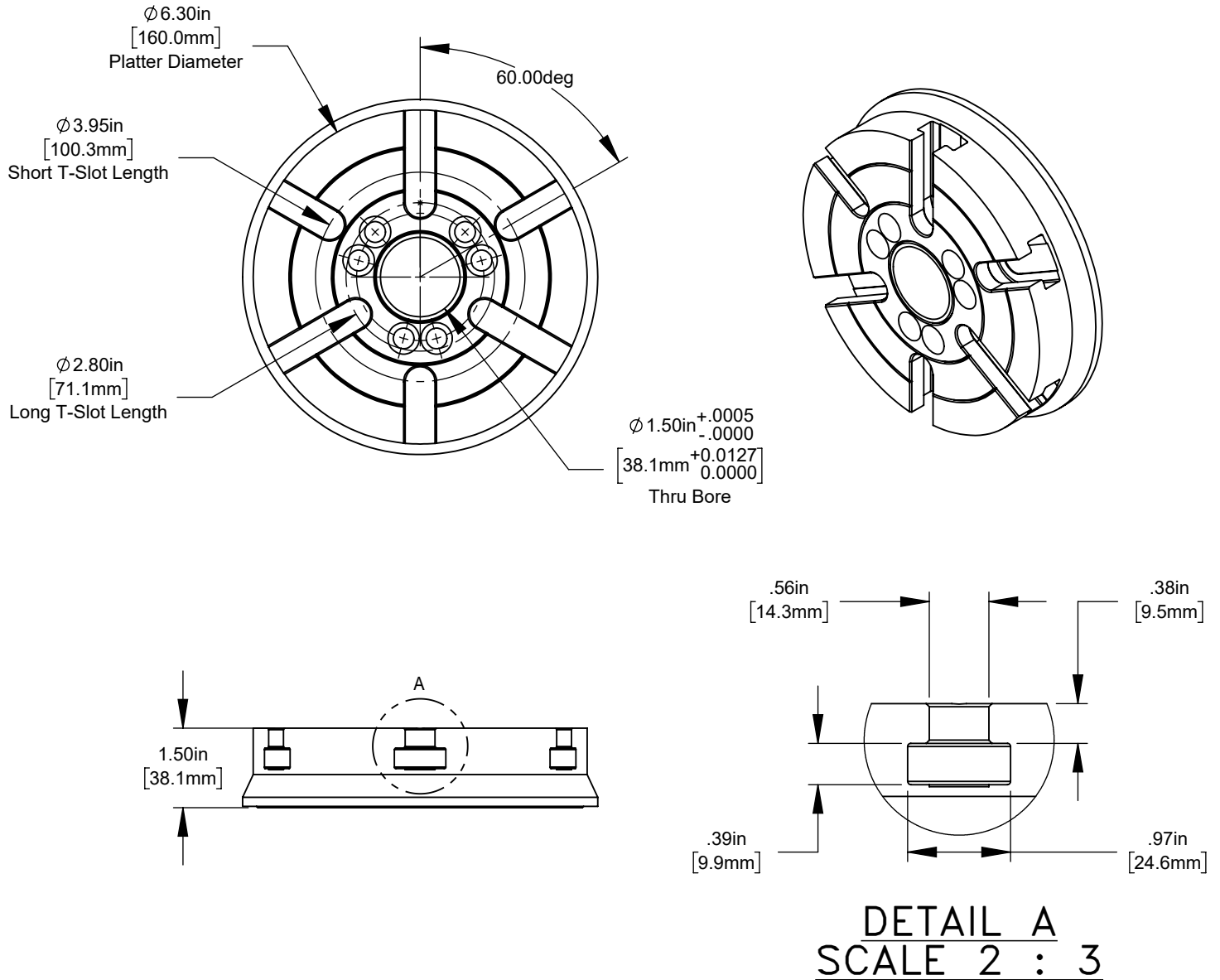

All dimensions based on stackup of sheetmetal, subject to variation of 1/2" ( 13 mm)

\*Due to continual product improvements, machine dimensions are subject to change without notice.