

Standard Tool Changer:  
20 Station Umbrella Tool Changer  
30+1 Station Side-Mount Tool Changer  
50+1 Station Side-Mount Tool Changer

**Operating Dimensions**

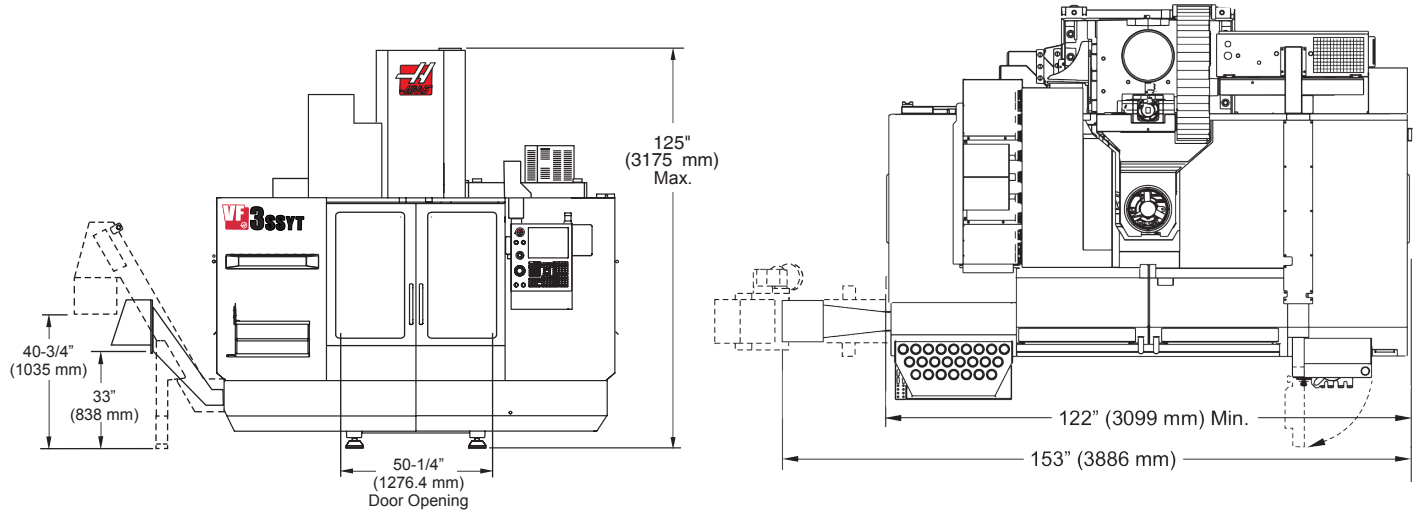

Option: Multi-Auger Chip Conveyor

Minimum distance required to remove conveyor from mill is 85in (2159mm) without folding the conveyor.

Minimum distance required to remove conveyor is 50in (1270mm) when the conveyor is folded at 90 degrees and folded down as if removed.

## X/Y Axis Clearances

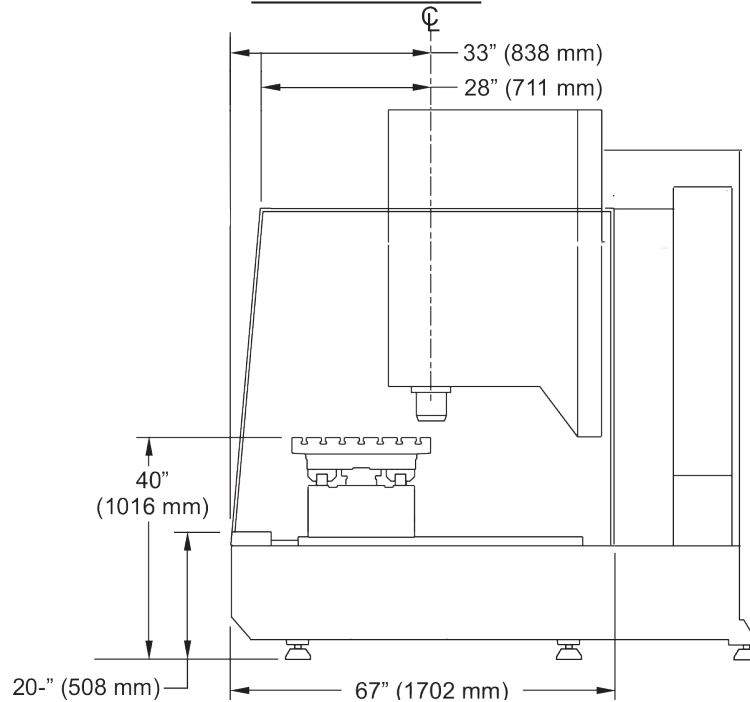

**Notes:**

1. The table shown is at XY home, the dashed is the table at max XY travels.
2. Measurements are from the edge of the table to the nearest obstruction.
3. Dimensions shown are at the top of the table. Dimensions are reduced as the height increased (5 degree slope inside the sheet metal).
4. Dimensions are symmetrical unless otherwise stated.

## Z Axis Clearances

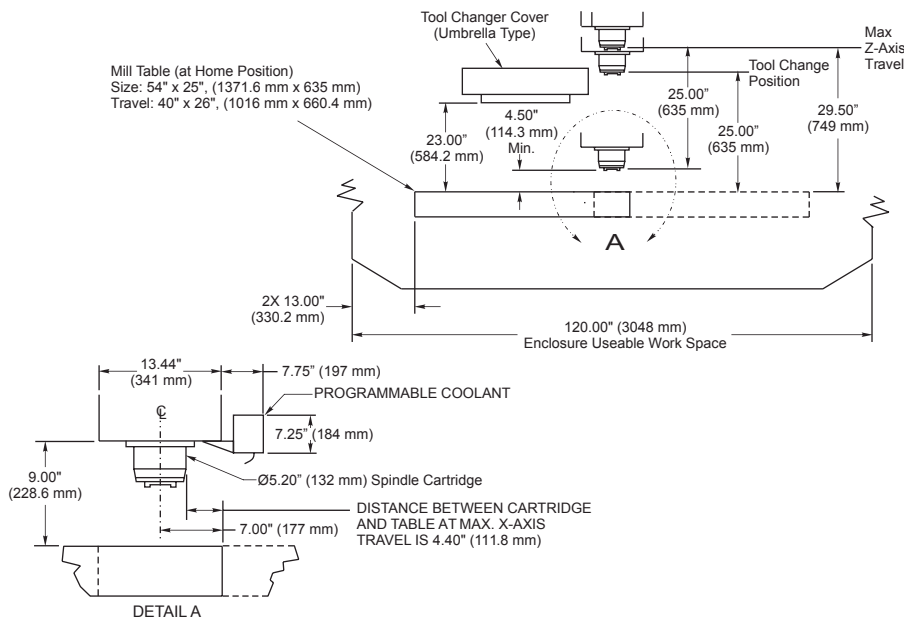

**Notes:**

1. The low-profile tables are 3 in(76mm) lower than the standard table.
2. P-COOL dimension varies based on P-COOL position.
3. Refer to the page on Tool Changer Dimensions for tool changer heights.

Table Dimensions

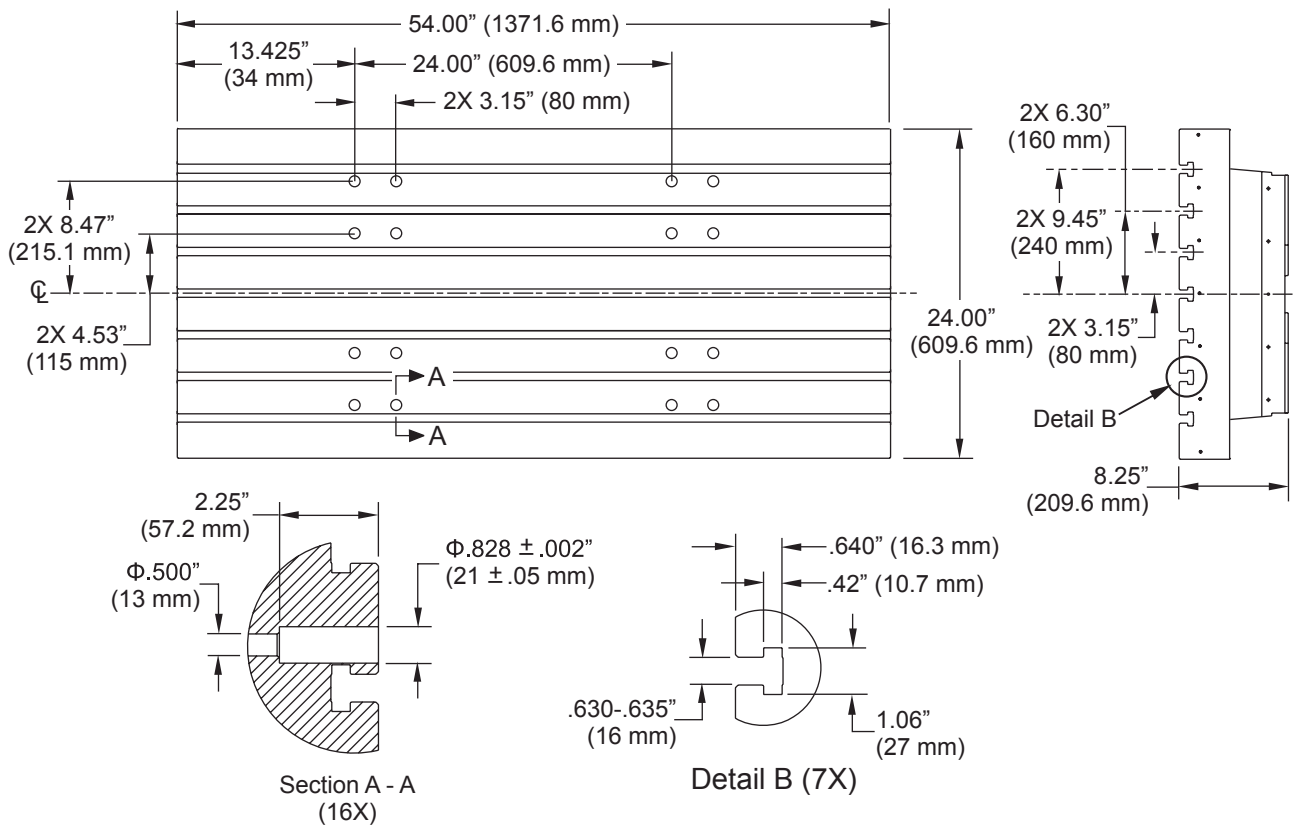

\*Due to continual product improvements, machine dimensions are subject to change without notice.

## Umbrella Tool Changer Travels

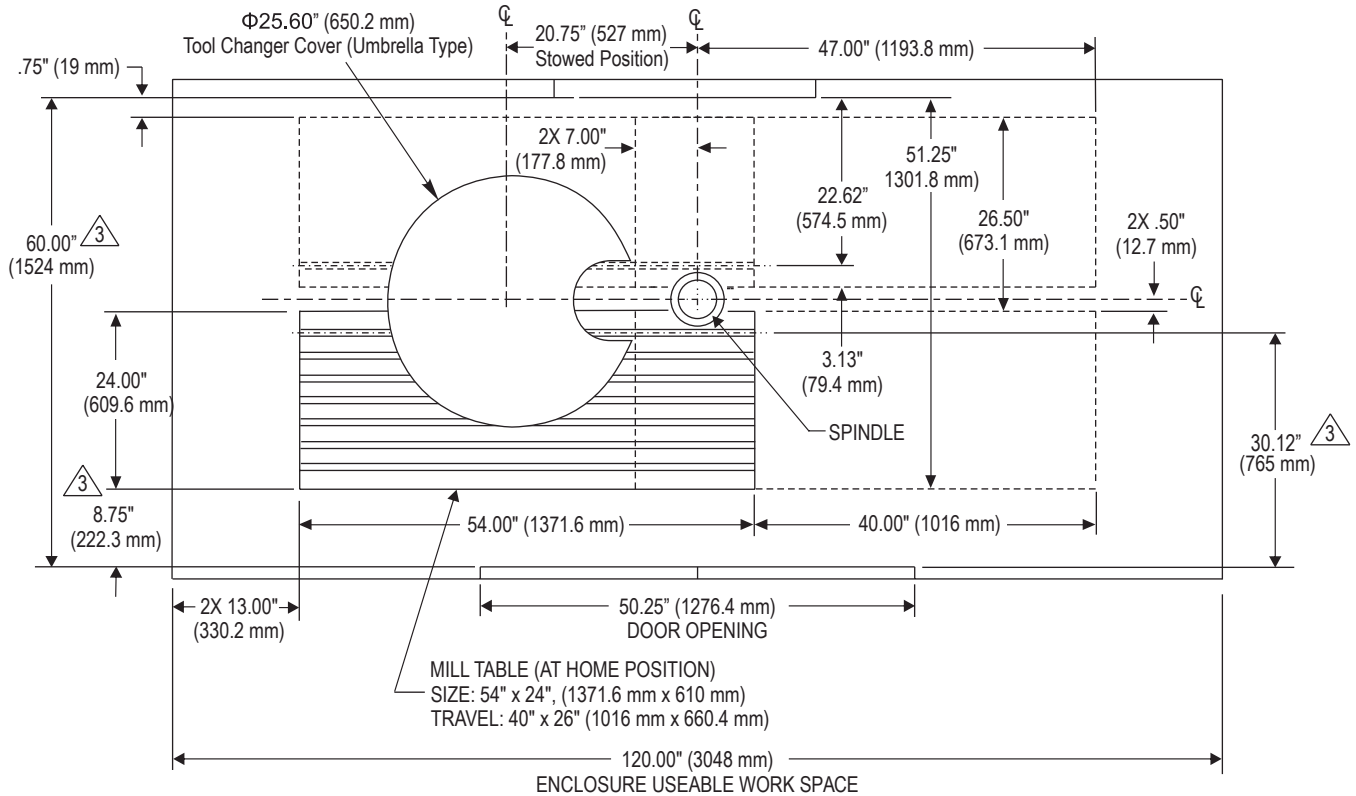

**NOTES:**

1. TABLE POSITION(S) AT MAX X & Y TRAVELS.
2. MEASUREMENTS ARE FROM THE EDGE OF MILL TABLE TO NEAREST OBSTRUCTION (ie. ENCLOSURE, WAY COVER, DOORS, ECT.).
3. DIMENSIONS ARE REDUCED AS HEIGHT ABOVE TABLE INCREASES; ie. FRONT OF ENCLOSURE IS SLOPED 5° INWARD FROM BOTTOM TO TOP. DIMENSIONS SHOWN ARE AT TABLE TOP HEIGHT.

**Note:**

The Umbrella Tool Changer moves in towards the spindle to do a tool change.