

DIGITAL READOUT IS STANDARD  
NOT SHOWN BELOW  
ADDS 9in [228mm] HEIGHT HERE

FRONT VIEW

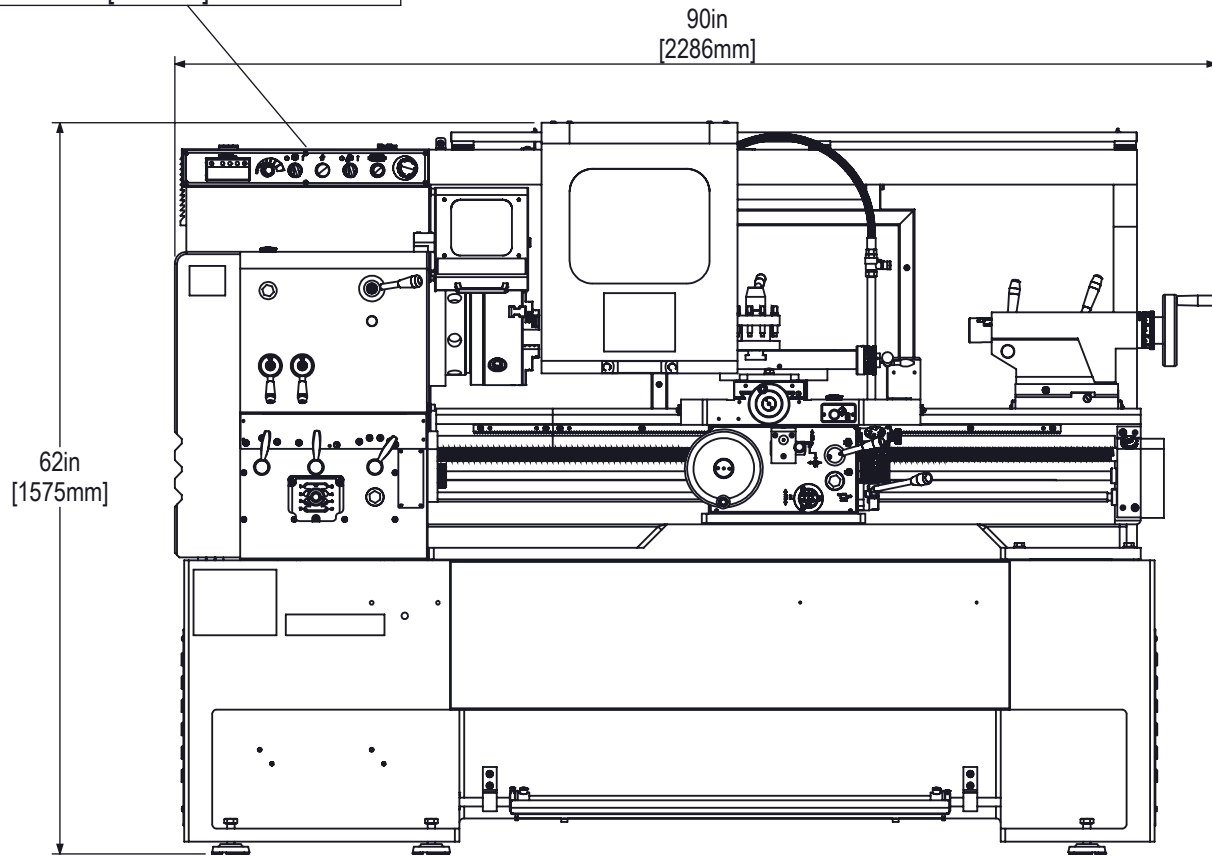

TOP VIEW

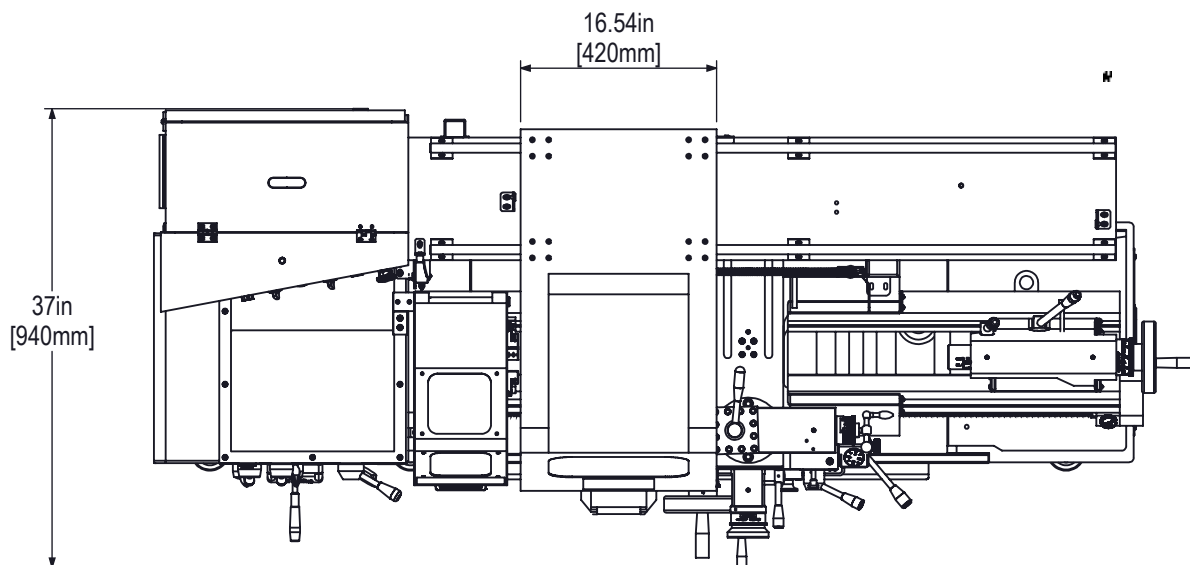

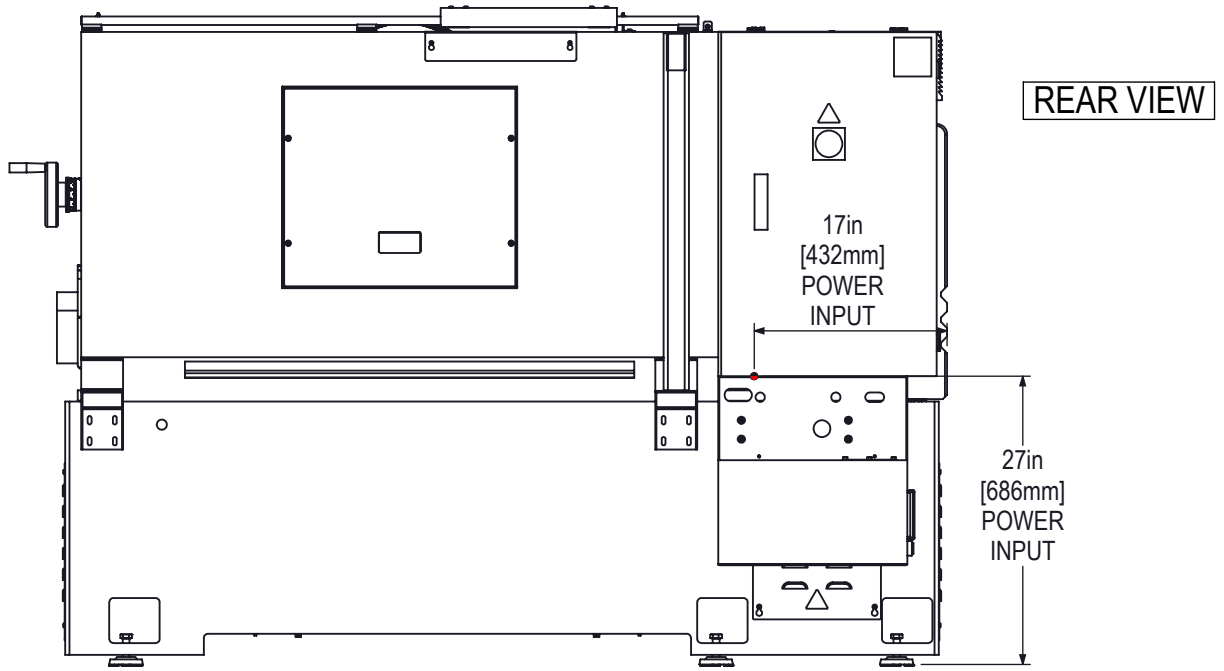

NO AIR REQUIRED

RIGHT SIDE VIEW

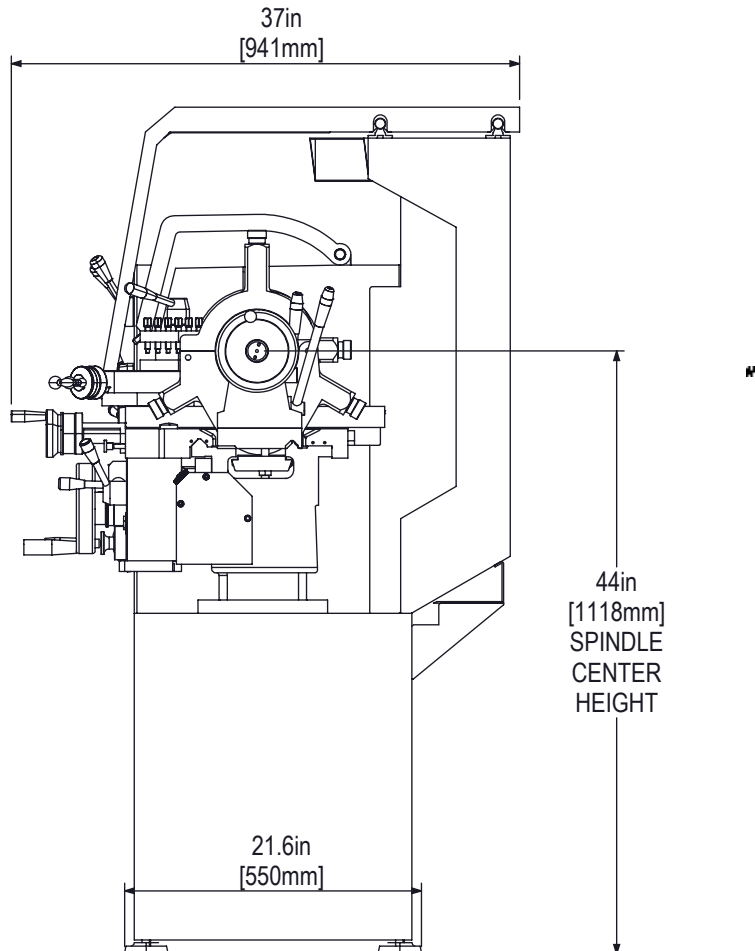

ANCHORING NOT REQUIRED

FRONT VIEW

DIGITAL READOUT IS STANDARD  
NOT SHOWN BELOW  
ADDS 9in [228mm] HEIGHT HERE

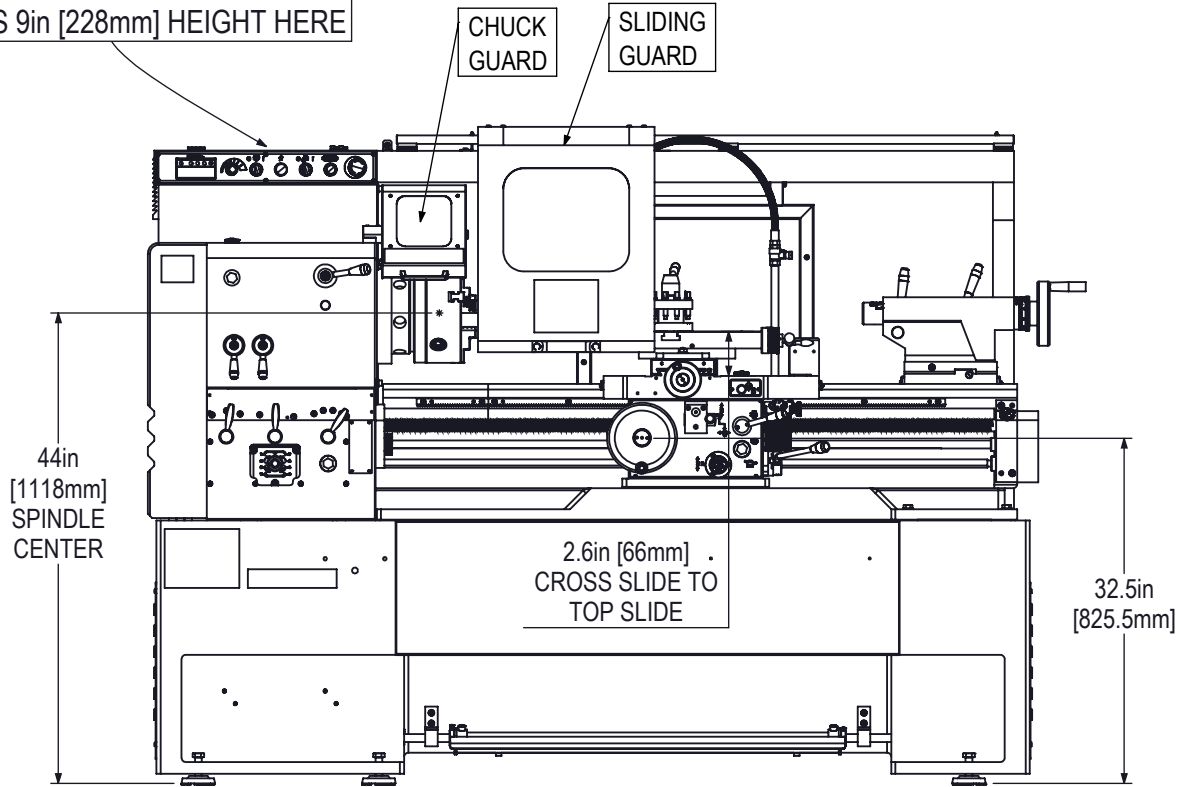

TOP VIEW

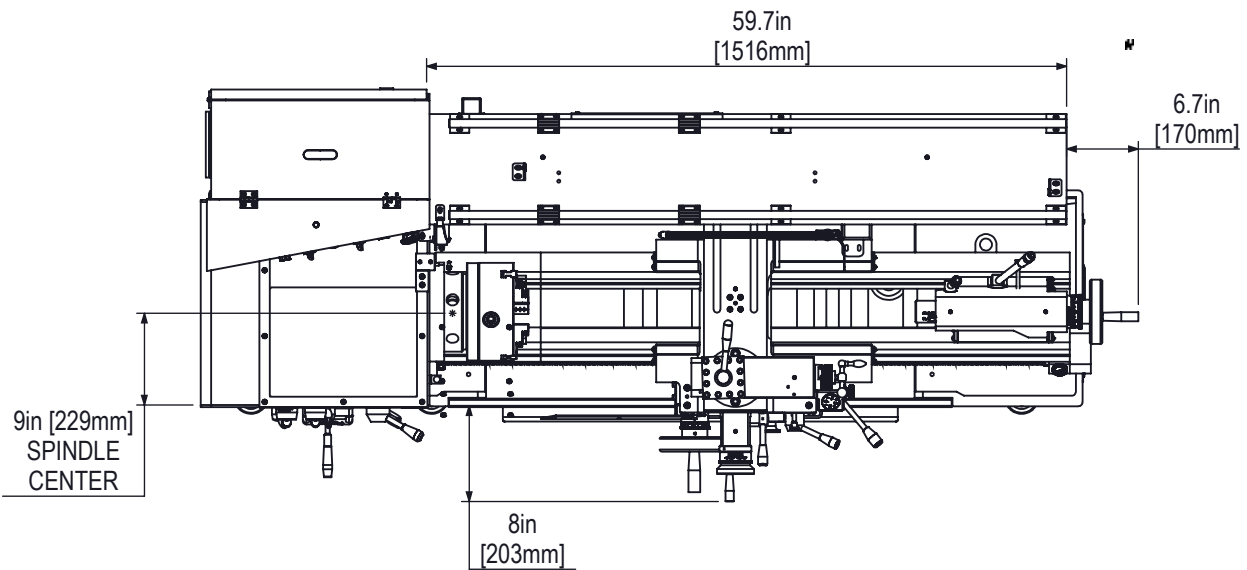

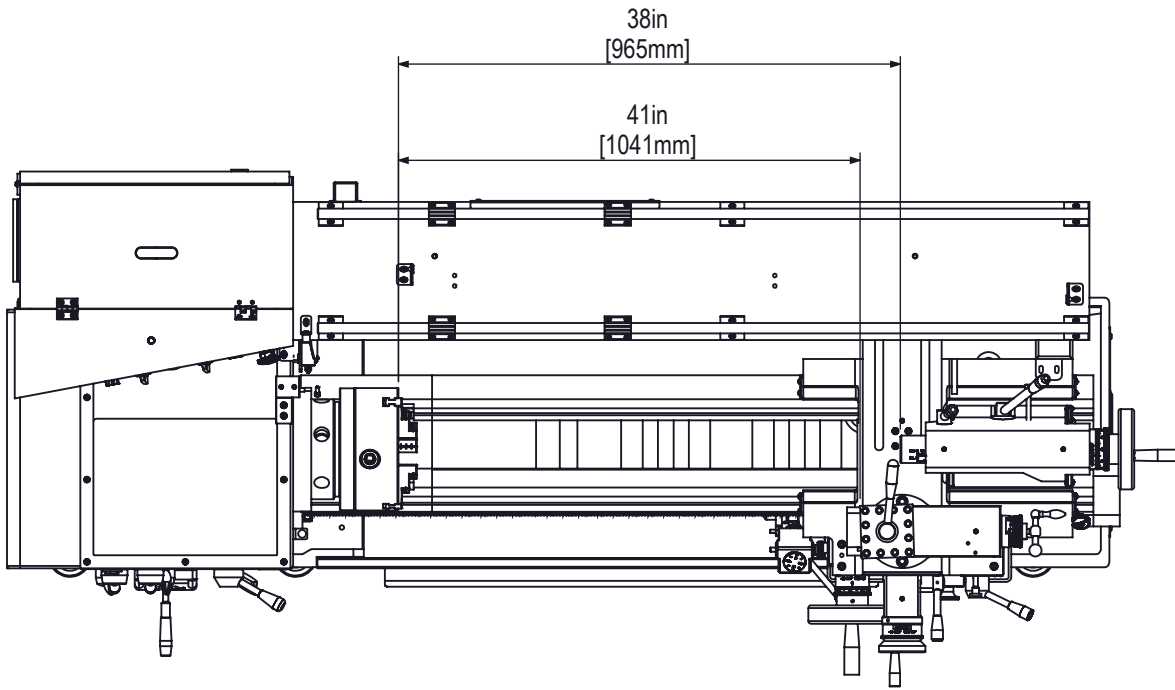

CARRIAGE, CROSS SLIDE AND  
TAILSTOCK AWAY FROM THE CHUCK

QUILL DIAMETER 2.05in [52mm]  
QUILL TRAVEL 5in [127mm]

TAILSTOCK TAPER  
MT4

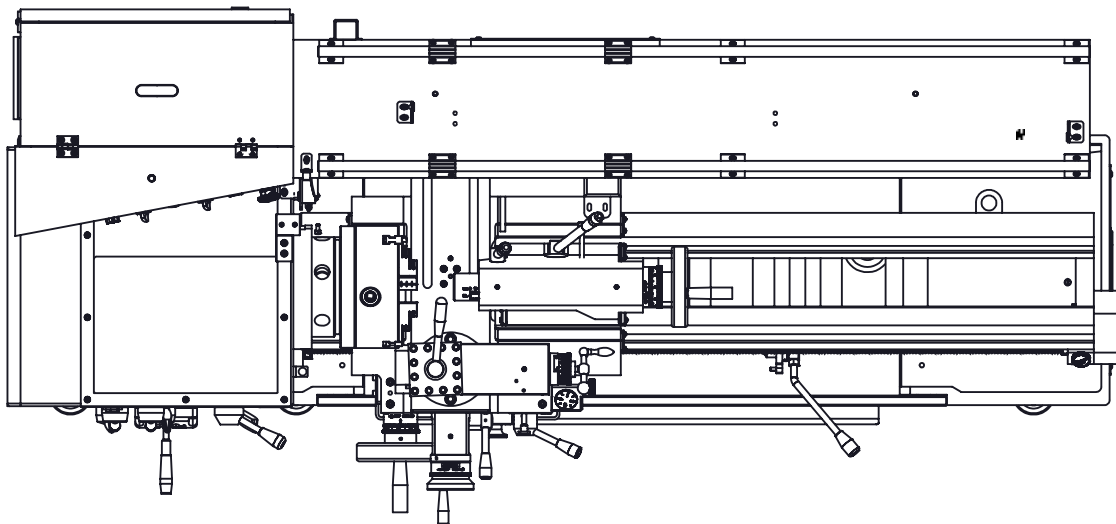

CARRIAGE, CROSS SLIDE AND  
TAILSTOCK NEAR THE CHUCK

OVER BED

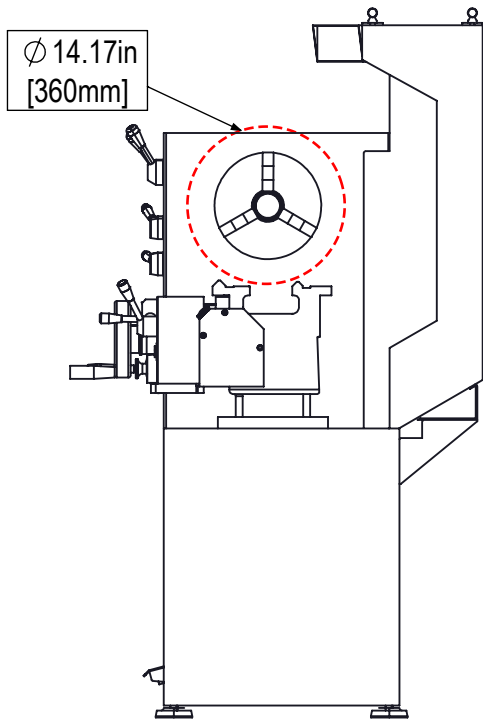

OVER CROSS SLIDE

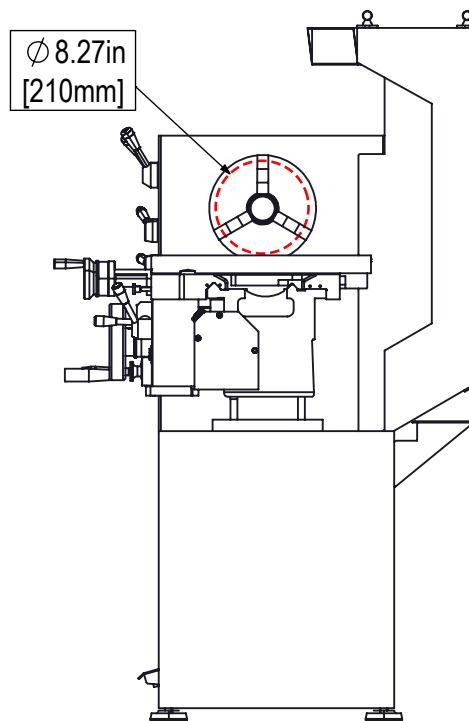

MAXIMUM SWING WITH GAP CASTING REMOVED

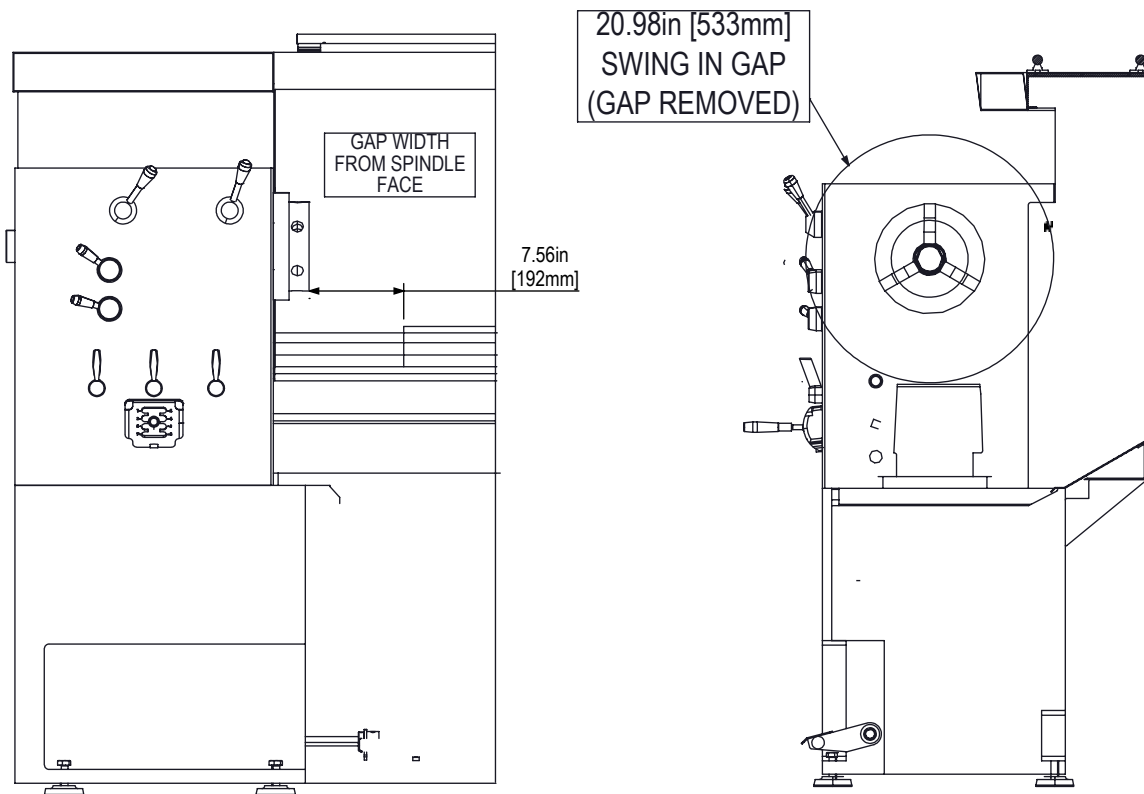

SIDE VIEW

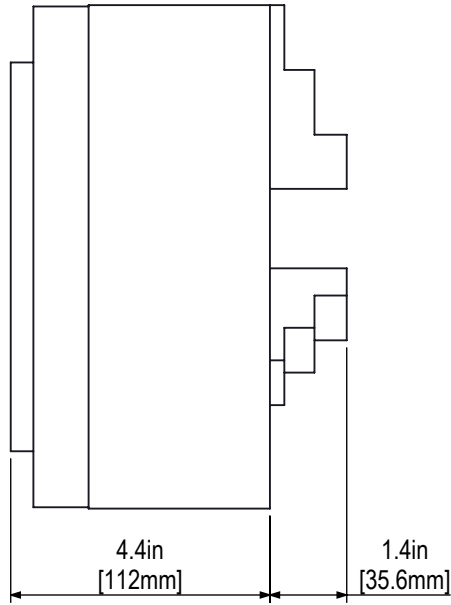

FRONT VIEW

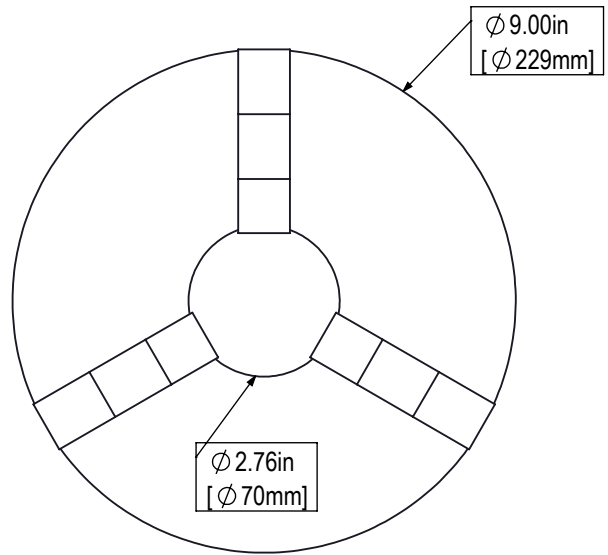

CHUCK BORE MAY VARY PER BRAND

TOP VIEW

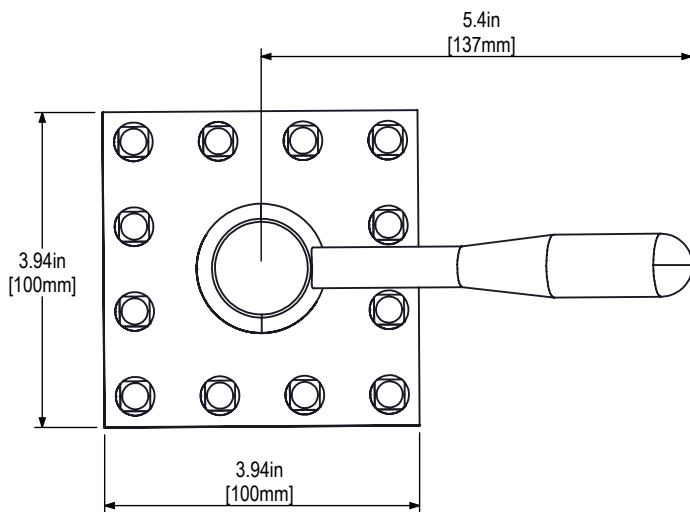

FRONT VIEW

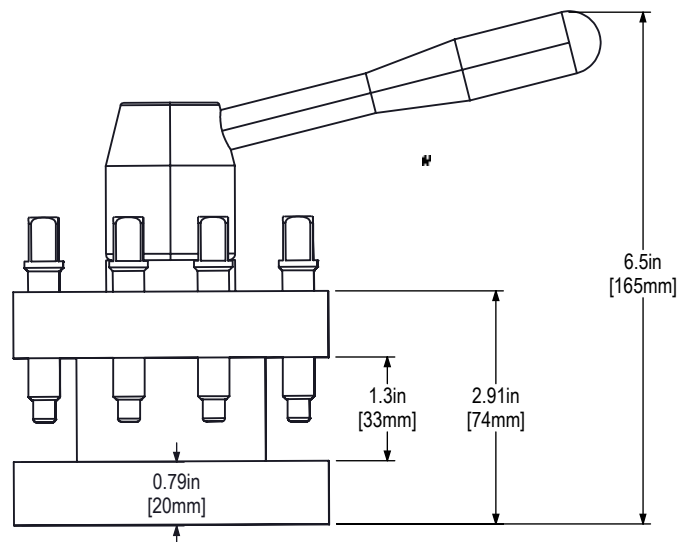

4-STATION MANUAL TOOL POST FOR 20mm (0.787in) TOOLS

20mm [0.787]  
SQUARE SHANK  
TOOLS REQUIRED

FOLLOW REST MAXIMUM CAPACITY

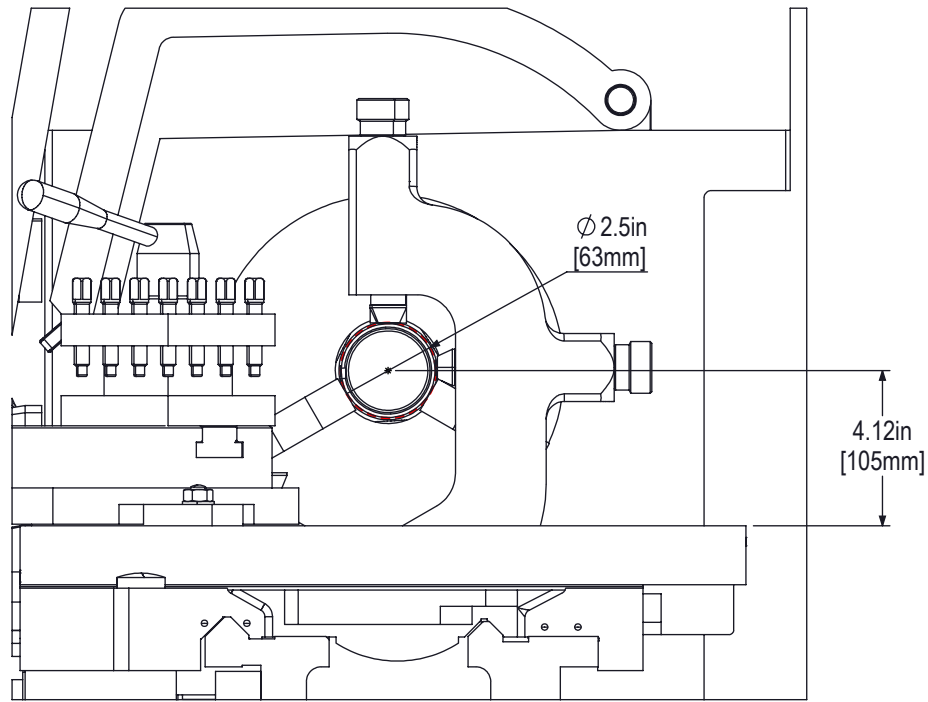

STEADY REST MAXIMUM CAPACITY

