

DIGITAL READOUT IS STANDARD  
NOT SHOWN BELOW  
ADDS 9in [228mm] HEIGHT HERE

FRONT VIEW

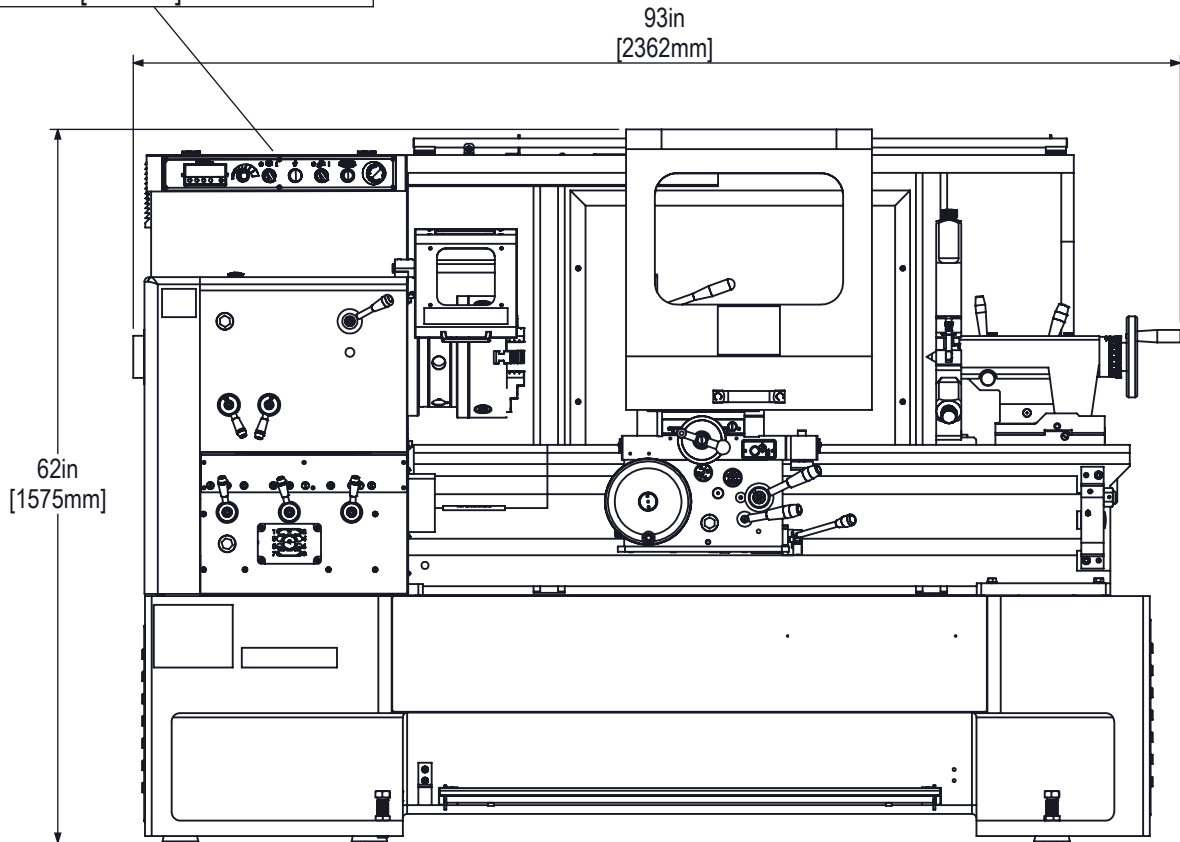

TOP VIEW

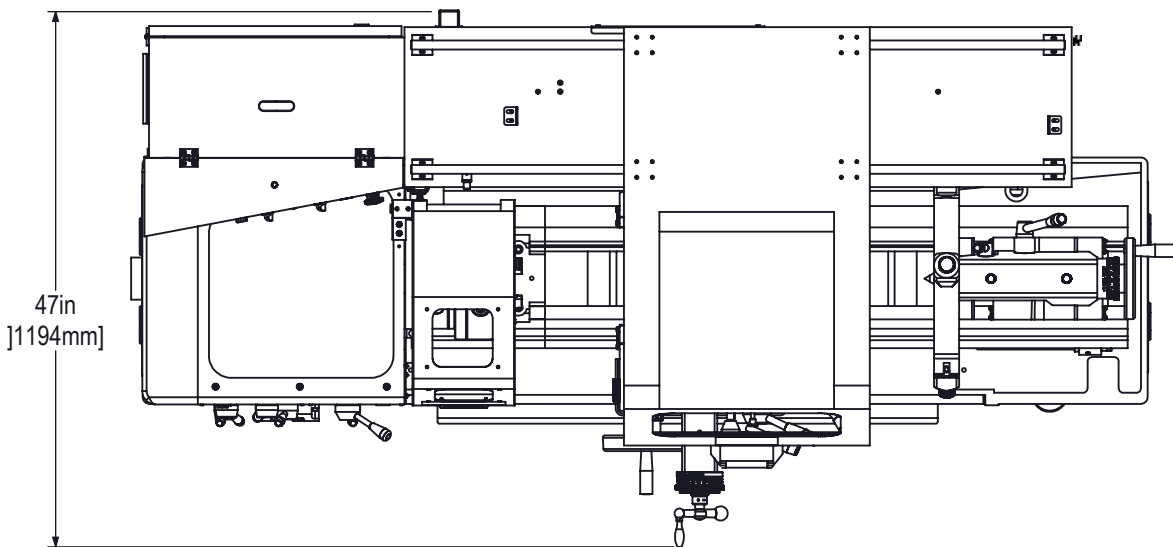

REAR VIEW

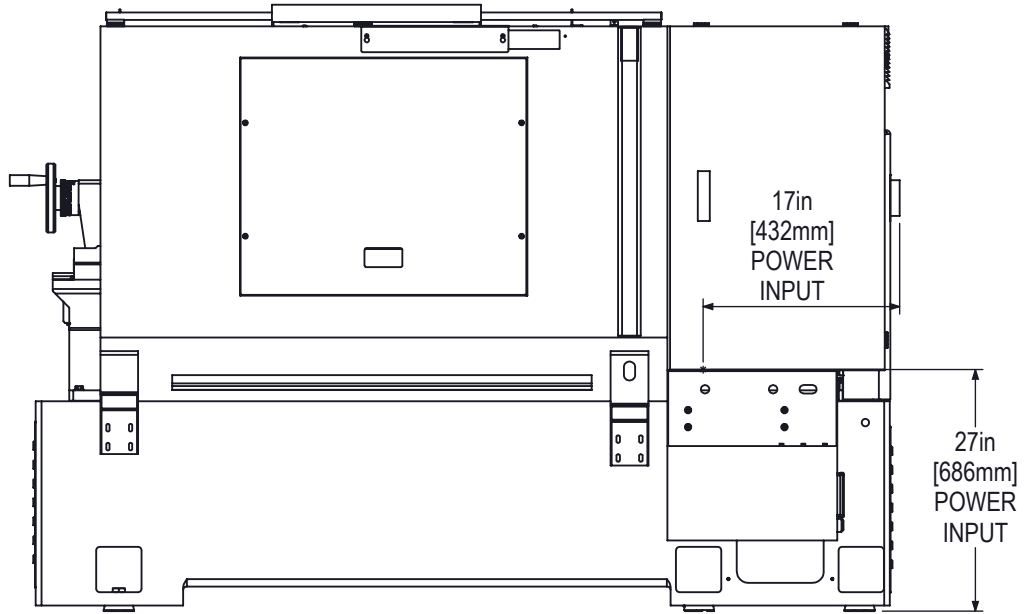

NO AIR REQUIRED

RIGHT SIDE VIEW

ANCHORING  
NOT REQUIRED

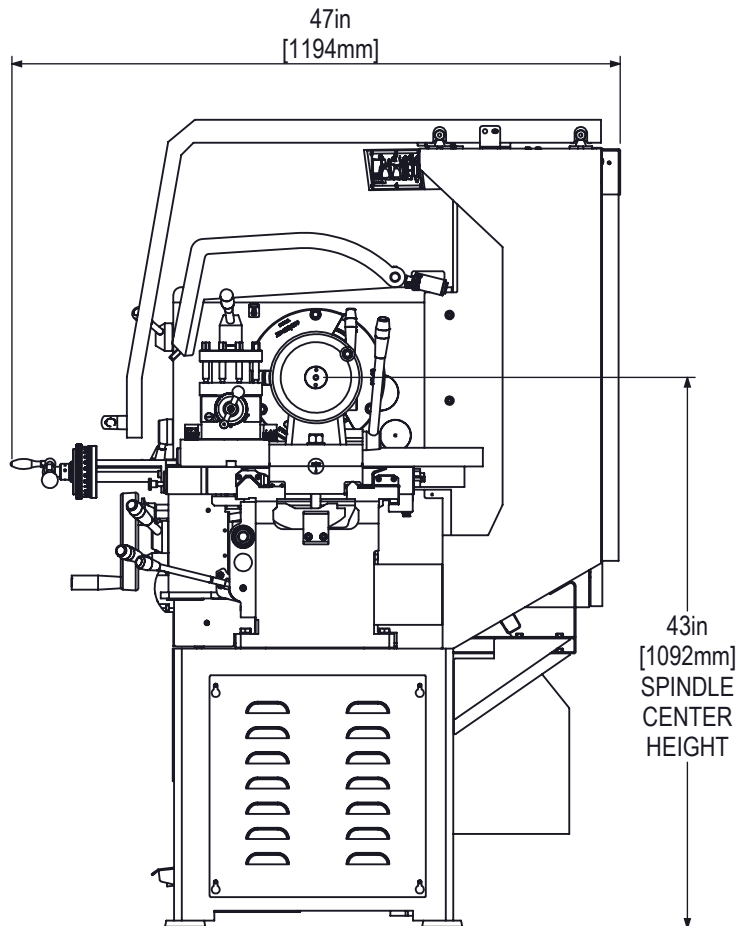

DIGITAL READOUT IS STANDARD  
NOT SHOWN BELOW  
ADDS 9in [228mm] HEIGHT HERE

FRONT VIEW

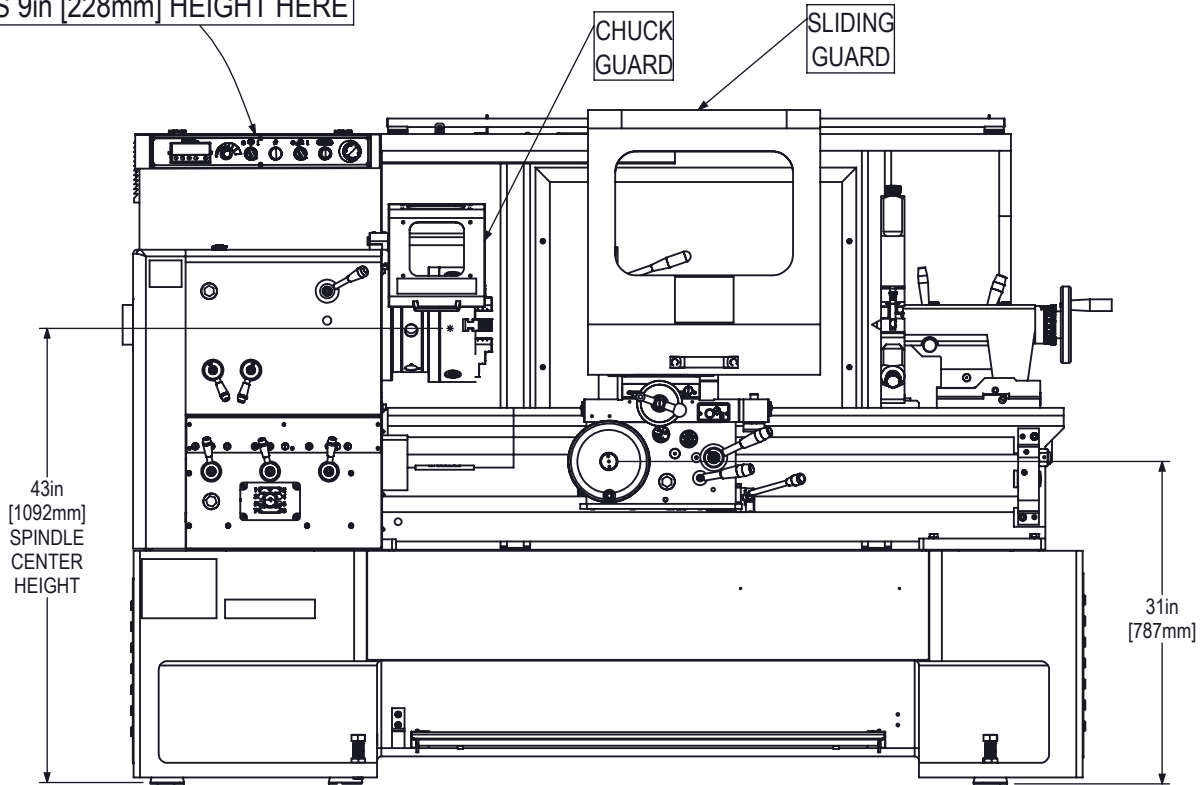

TOP VIEW

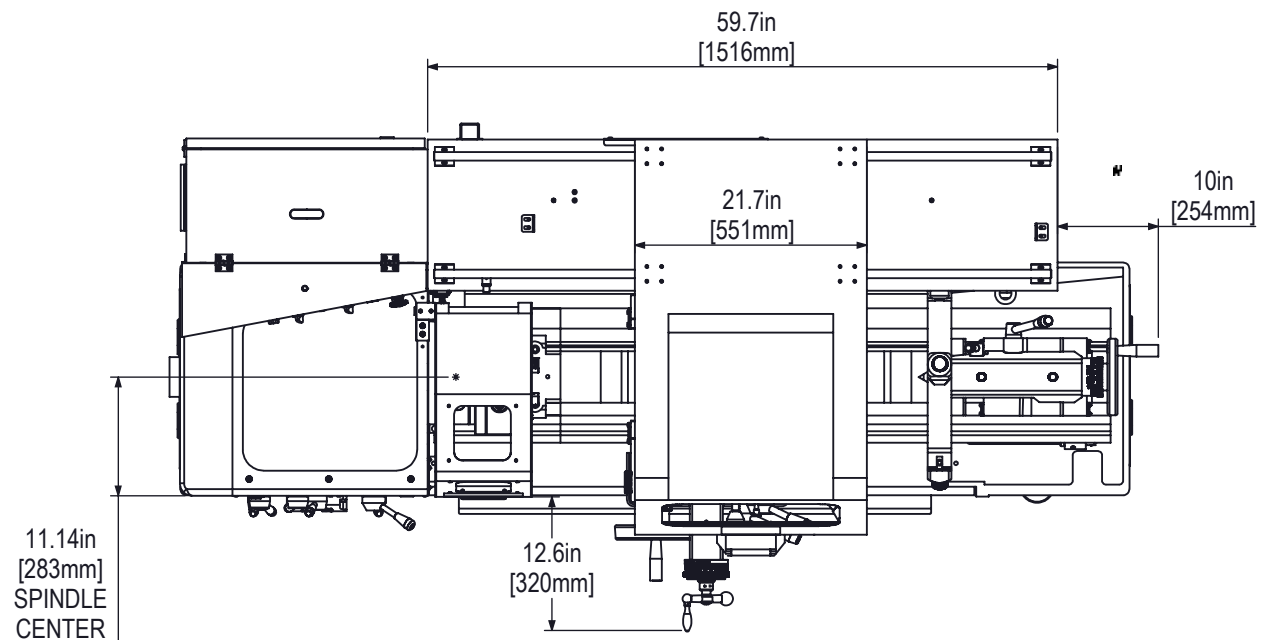

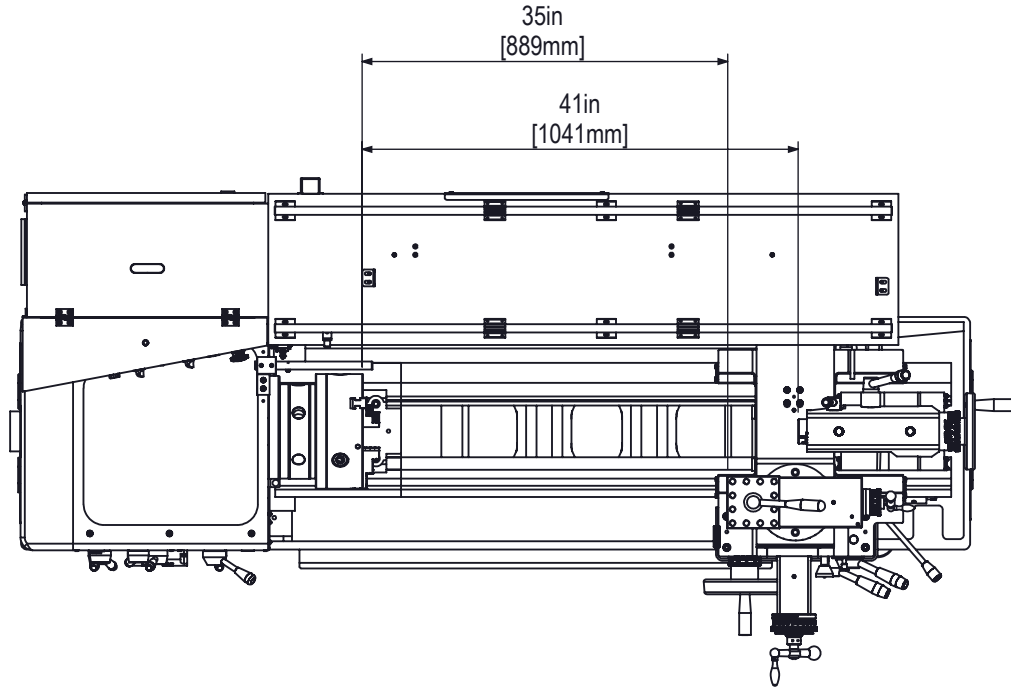

CARRIAGE, CROSS SLIDE AND  
TAILSTOCK AWAY FROM THE CHUCK

TAILSTOCK TAPER  
MT4

QUILL DIAMETER 2.32in [59mm]  
QUILL TRAVEL 5in [127mm]

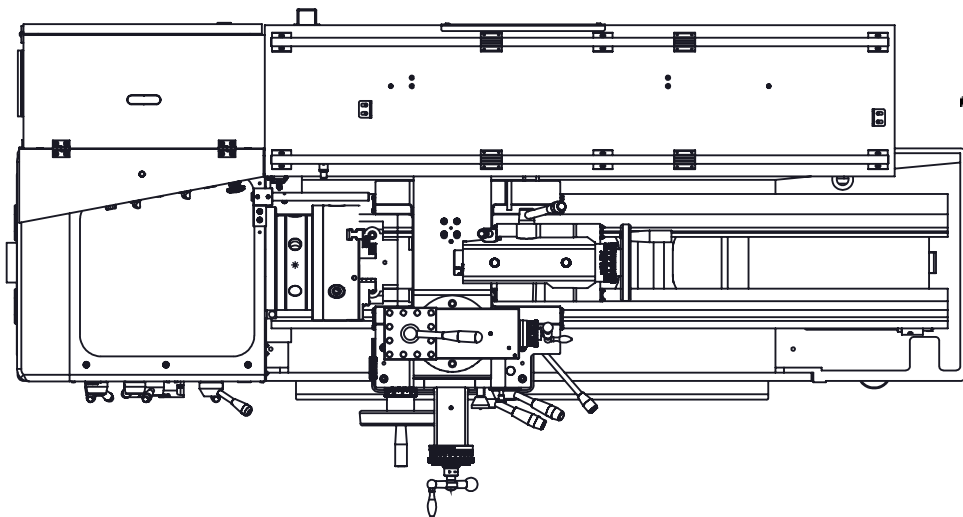

CARRIAGE, CROSS SLIDE AND  
TAILSTOCK NEAR THE CHUCK

OVER BED

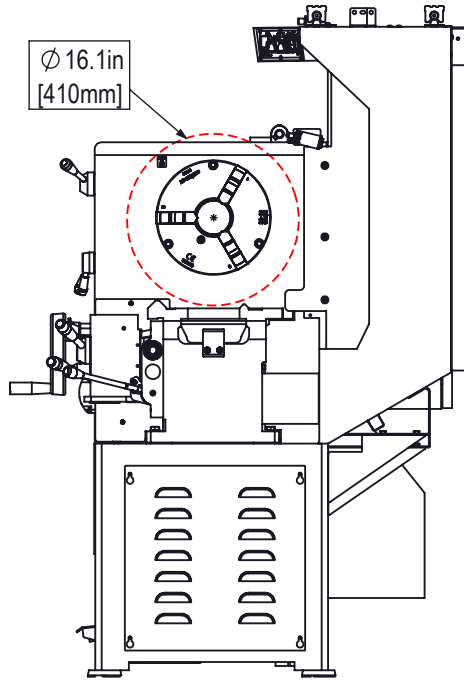

OVER CROSS SLIDE

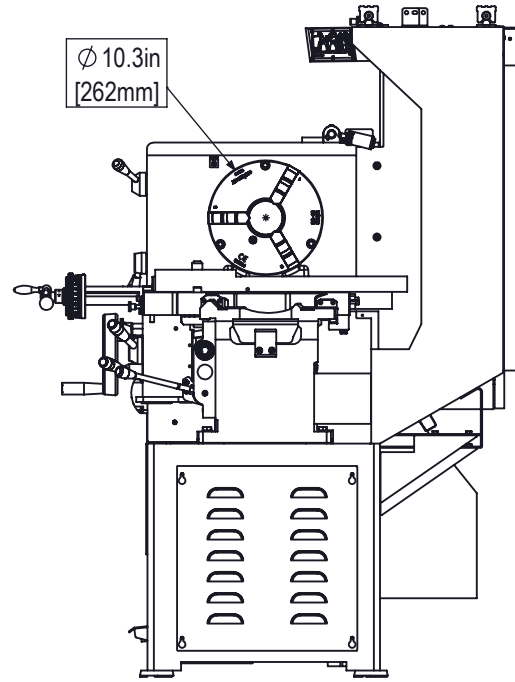

MAXIMUM SWING WITH GAP CASTING REMOVED

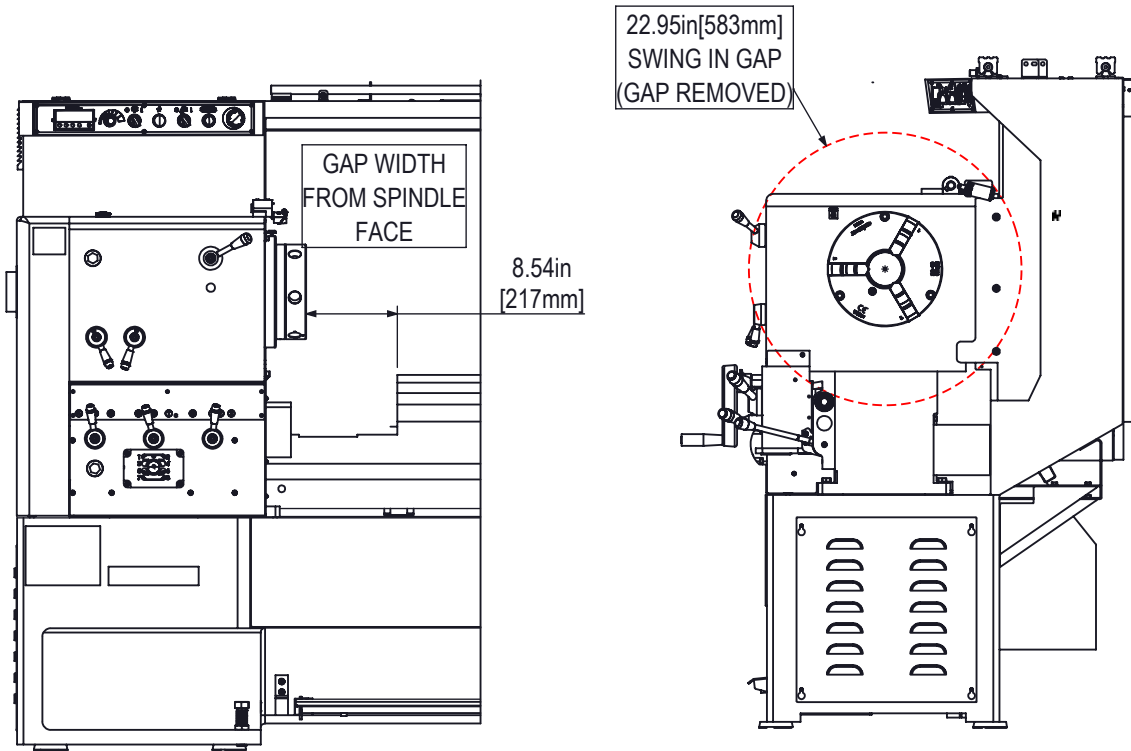

SIDE VIEW

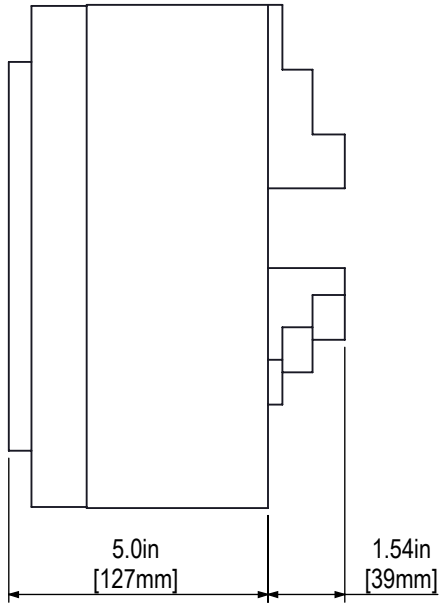

FRONT VIEW

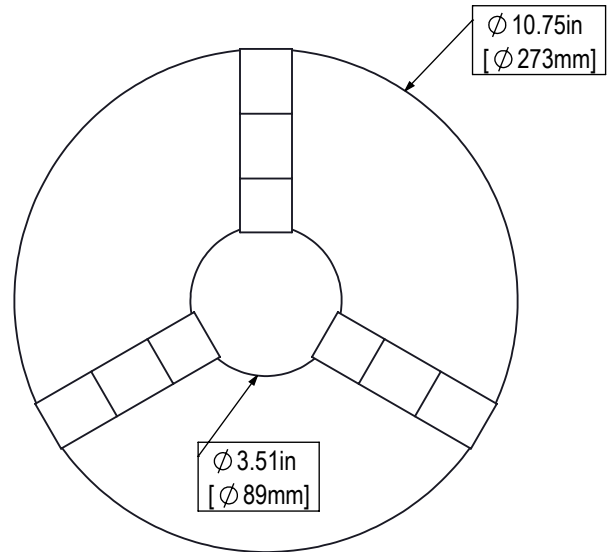

CHUCK BORE MAY VARY PER BRAND

TOP VIEW

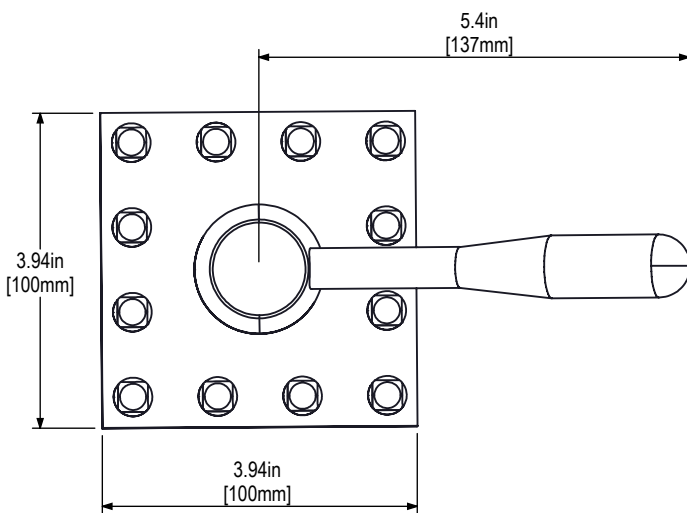

FRONT VIEW

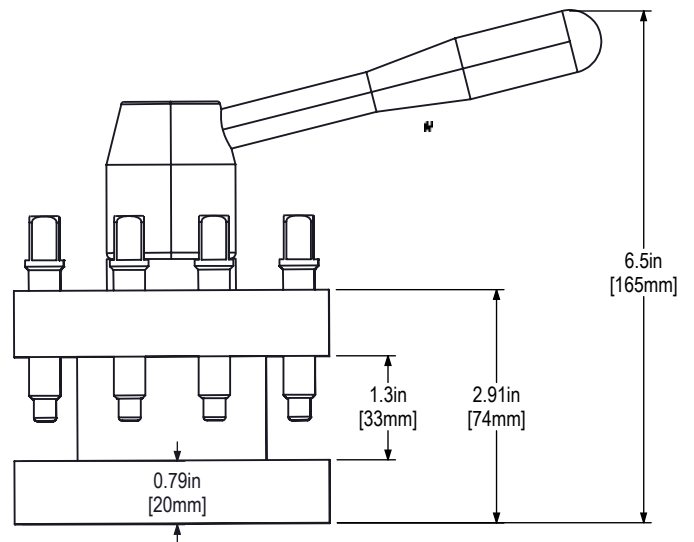

4-STATION MANUAL TOOL POST FOR 20mm (0.787in) TOOLS

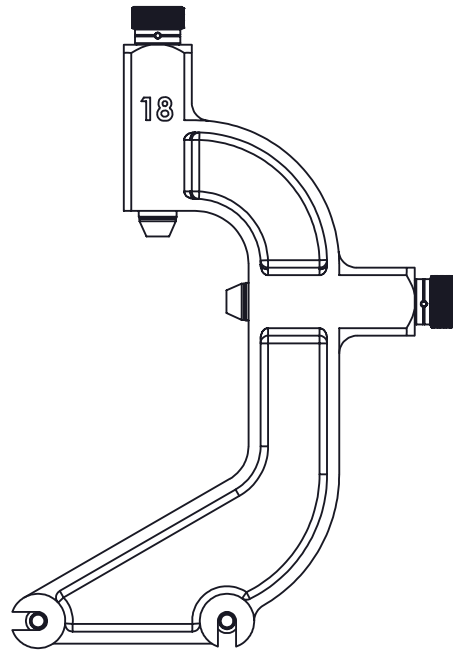

FOLLOW MAXIMUM  
 $\varnothing$  3.4in [  $\varnothing$  86.4mm]

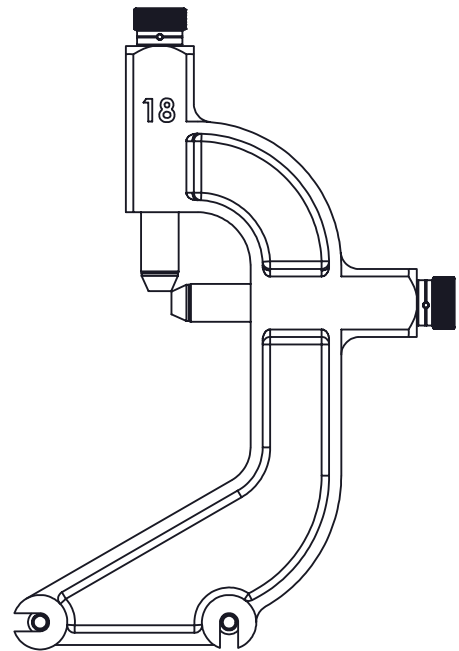

FOLLOW MINIMUM  
 $\varnothing$  0.6in [  $\varnothing$  15.2mm]

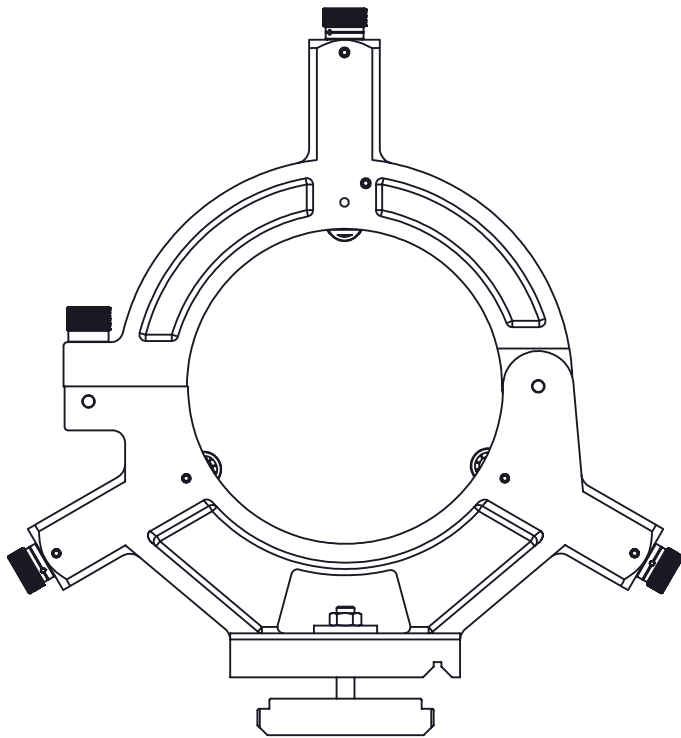

STEADY MAXIMUM  
 $\varnothing$  8.27in [  $\varnothing$  210mm]

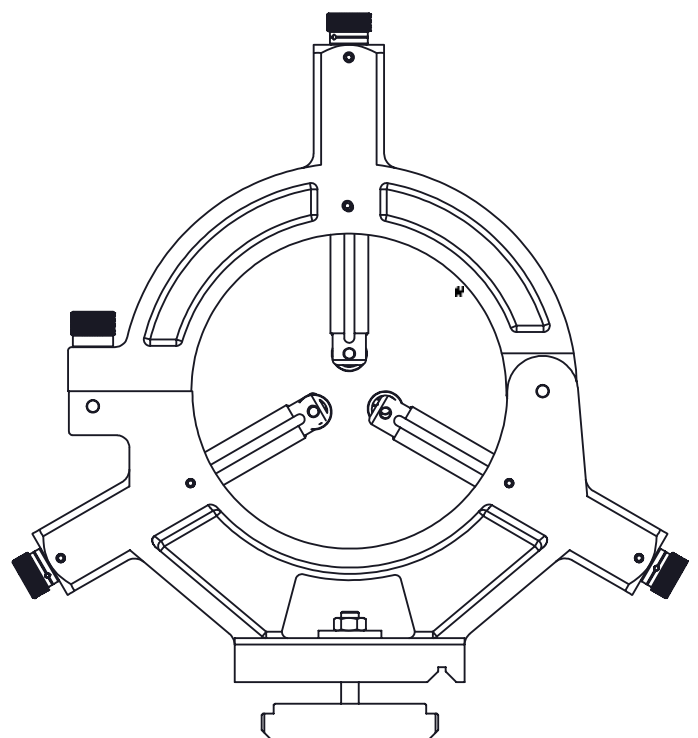

STEADY MINIMUM  
 $\varnothing$  1.5in [  $\varnothing$  38mm]