

All dimensions based on stackup of sheetmetal, subject to variation of 1/2" ( 13 mm)

\*Due to continual product improvements, machine dimensions are subject to change without notice.

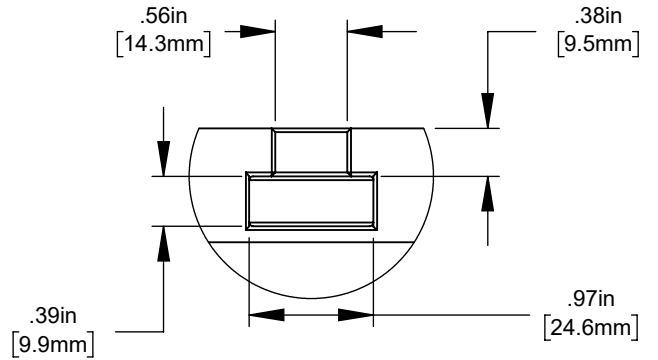
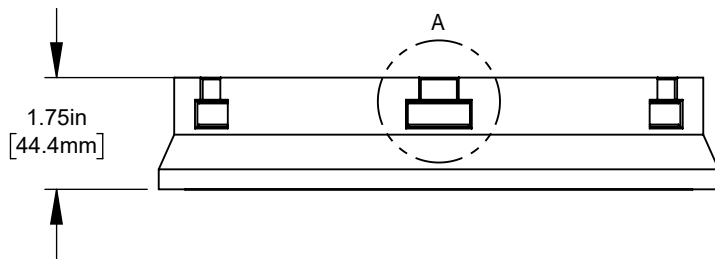
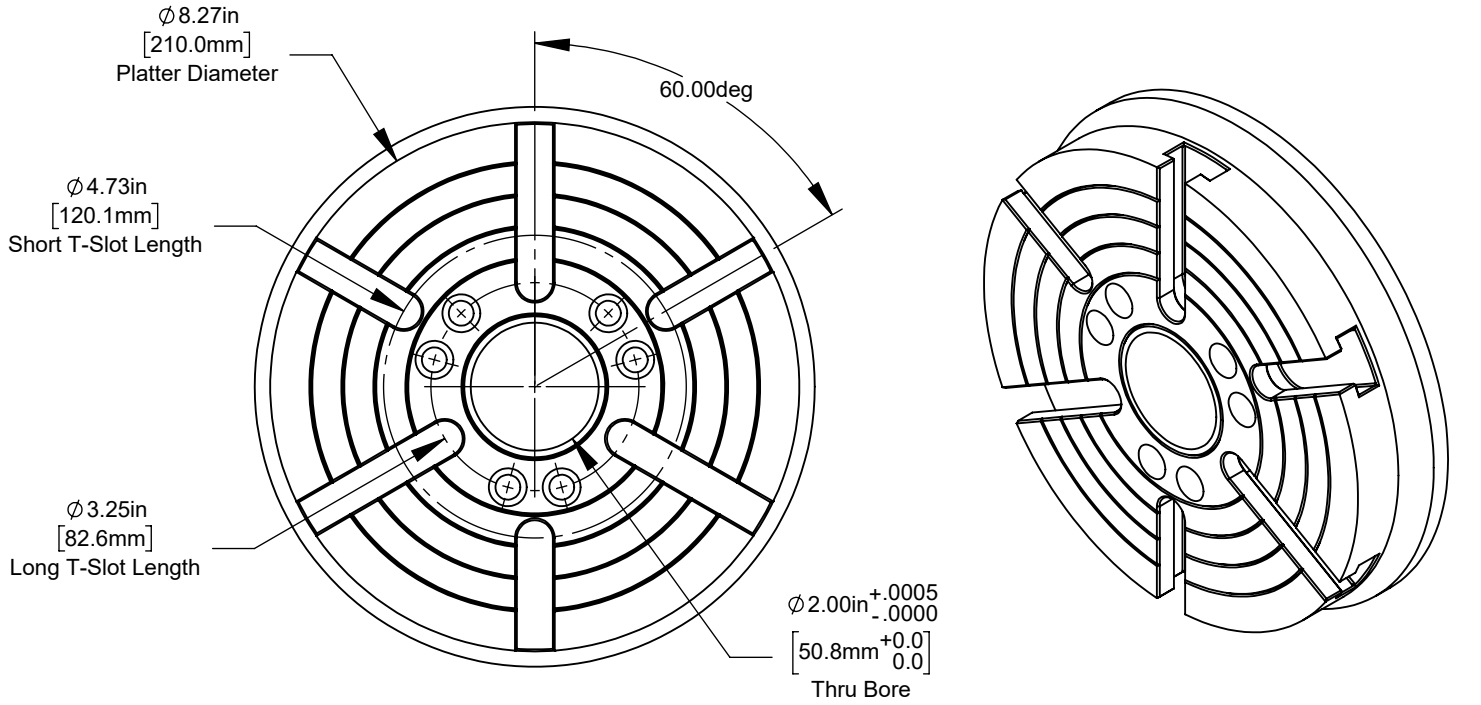

**DETAIL A**  
**SCALE 2 : 3**