

4X ϕ .42in [10.7mm] ∇ .90in [22.9mm]
1/2-13 UNC ∇ .63in [16.0mm]
Tapped Holes

.63in [16.0mm] Locating Key

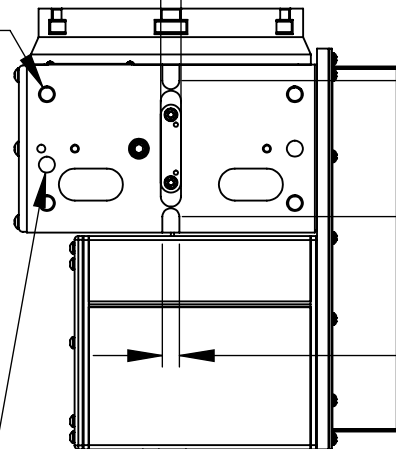

All dimensions based on stackup of sheetmetal, subject to variation of 1/2" (13 mm)

*Due to continual product improvements, machine dimensions are subject to change without notice.

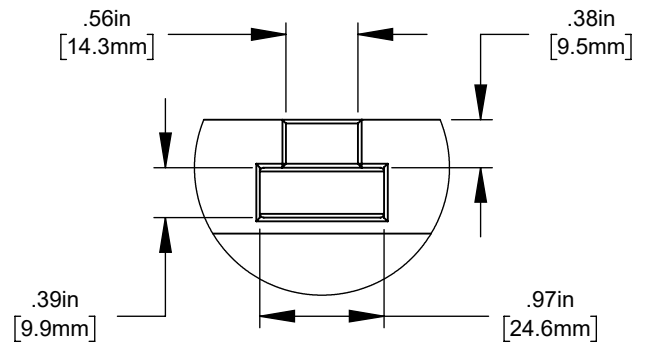
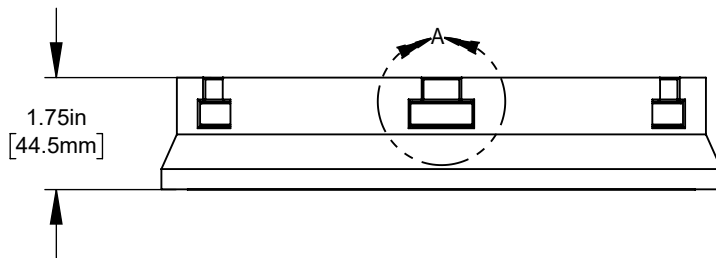
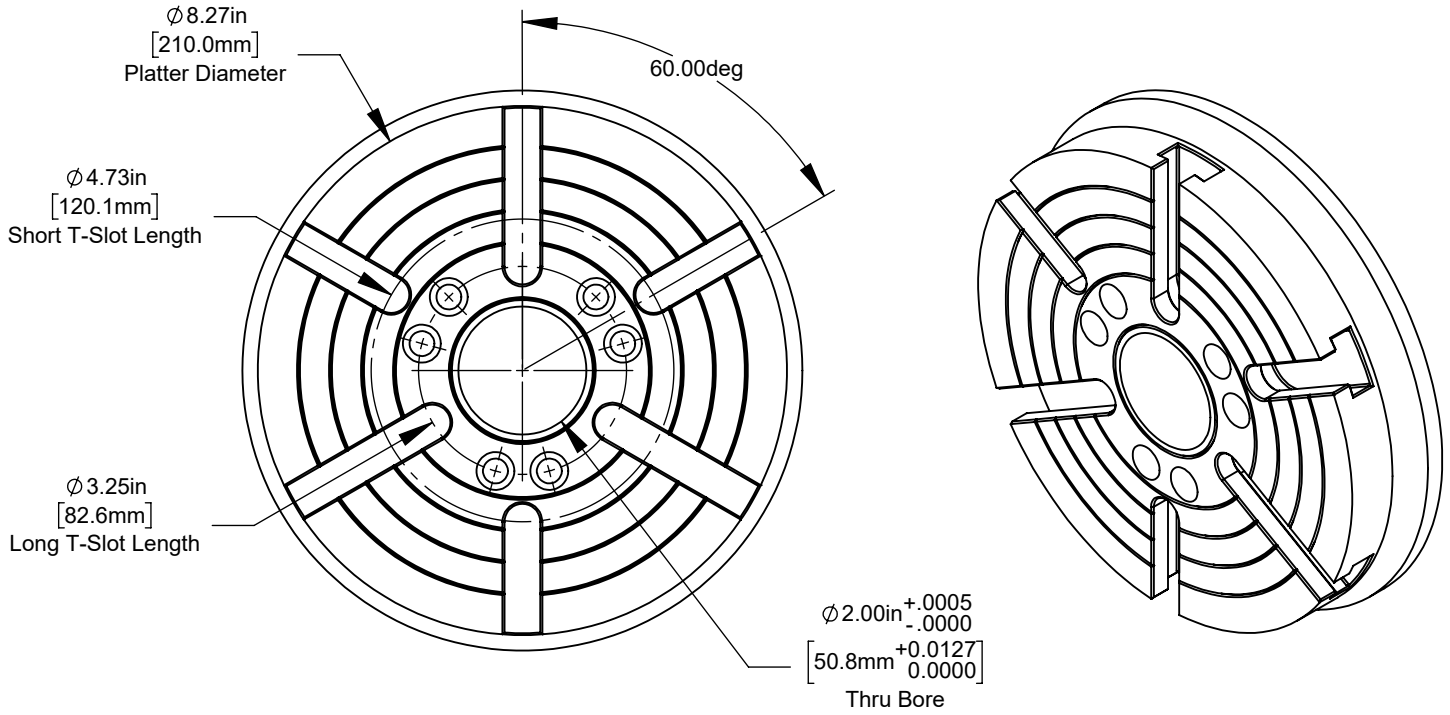

DETAIL A
SCALE 2 : 3