

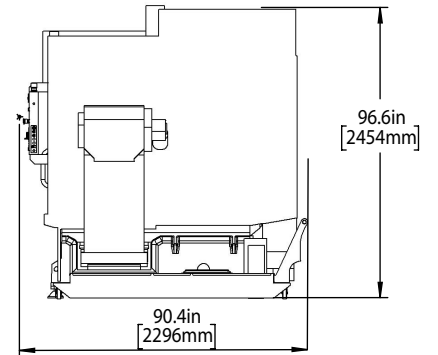

Installed Dimensions

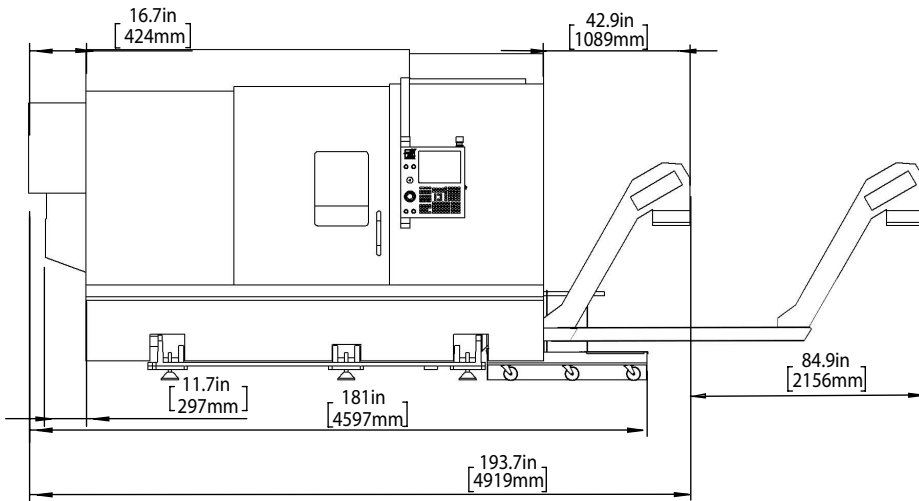
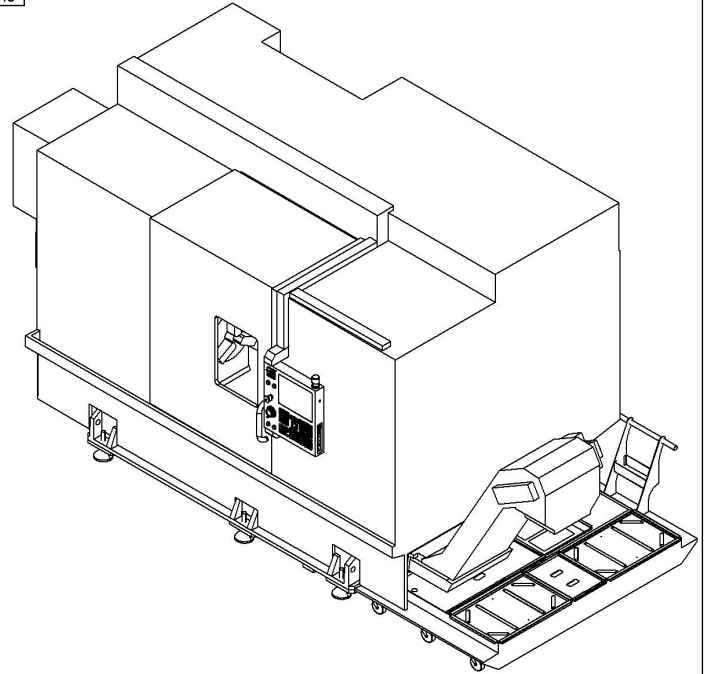
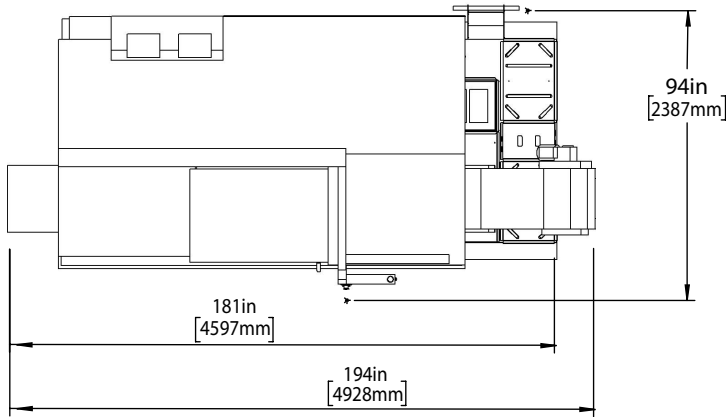

Shipping Dimensions

*All Height Dimensions Based on Suggested Leveling Pad Height

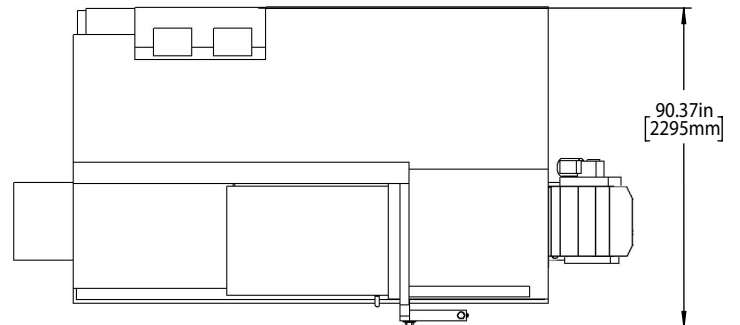
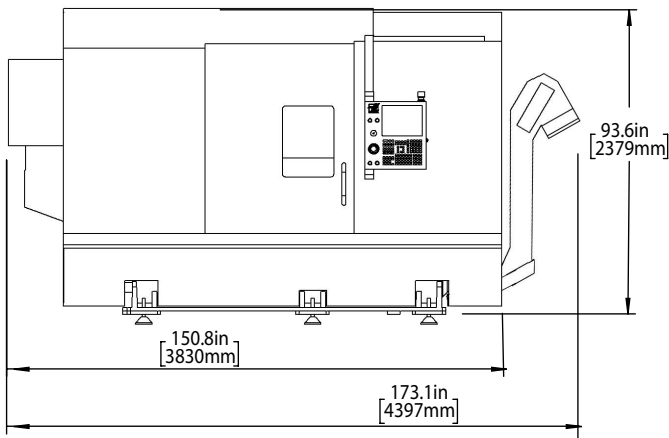

Air & Power

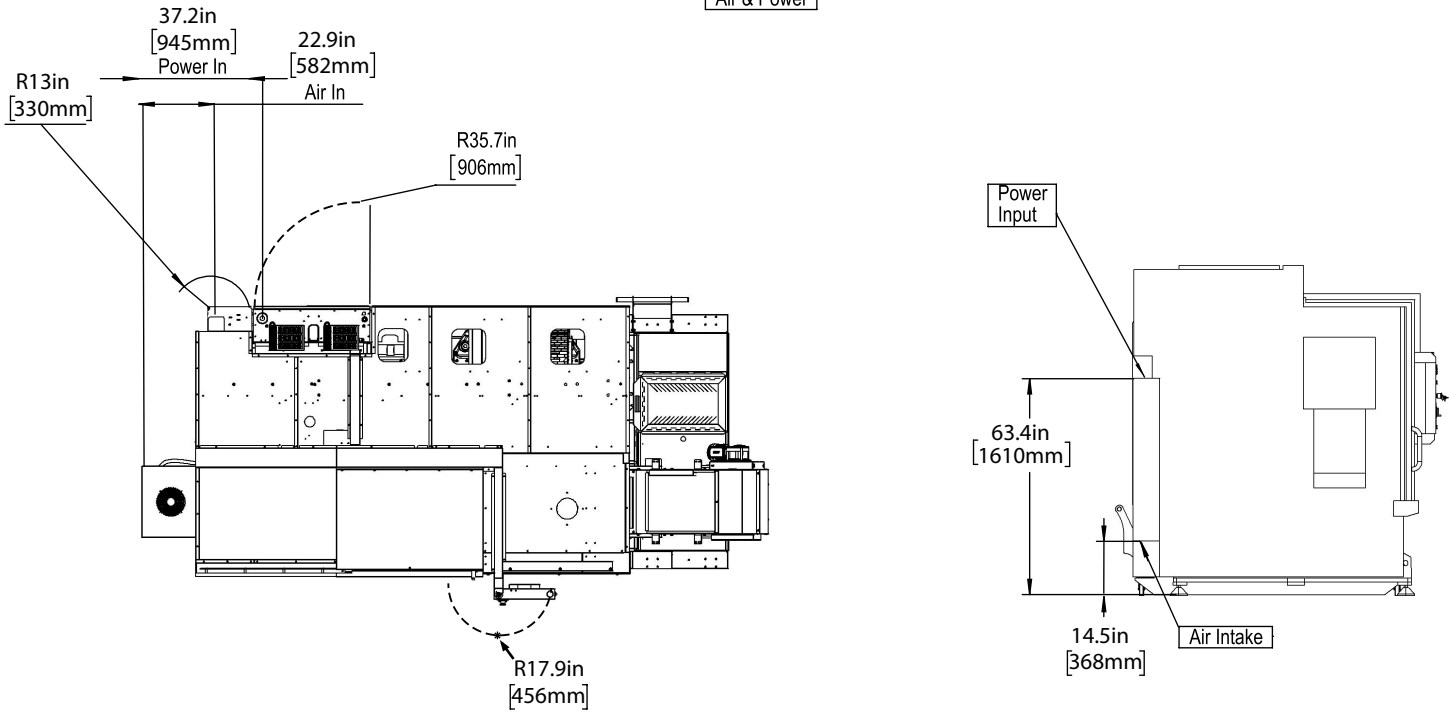

Maintain 3 feet [915mm] clearance to the nearest obstruction around all sides of machine perimeter for maintenance access

Note:

Machine must be placed on one continuous concrete slab. Slab should extend 12in [305mm] beyond anchor holes in all directions

Anchor Pattern

Anchor Hole Detail
 Ø 0.625in[25mm]
 ∇ 2.0in[50mm]-
 ∇ 2.25in[57mm]

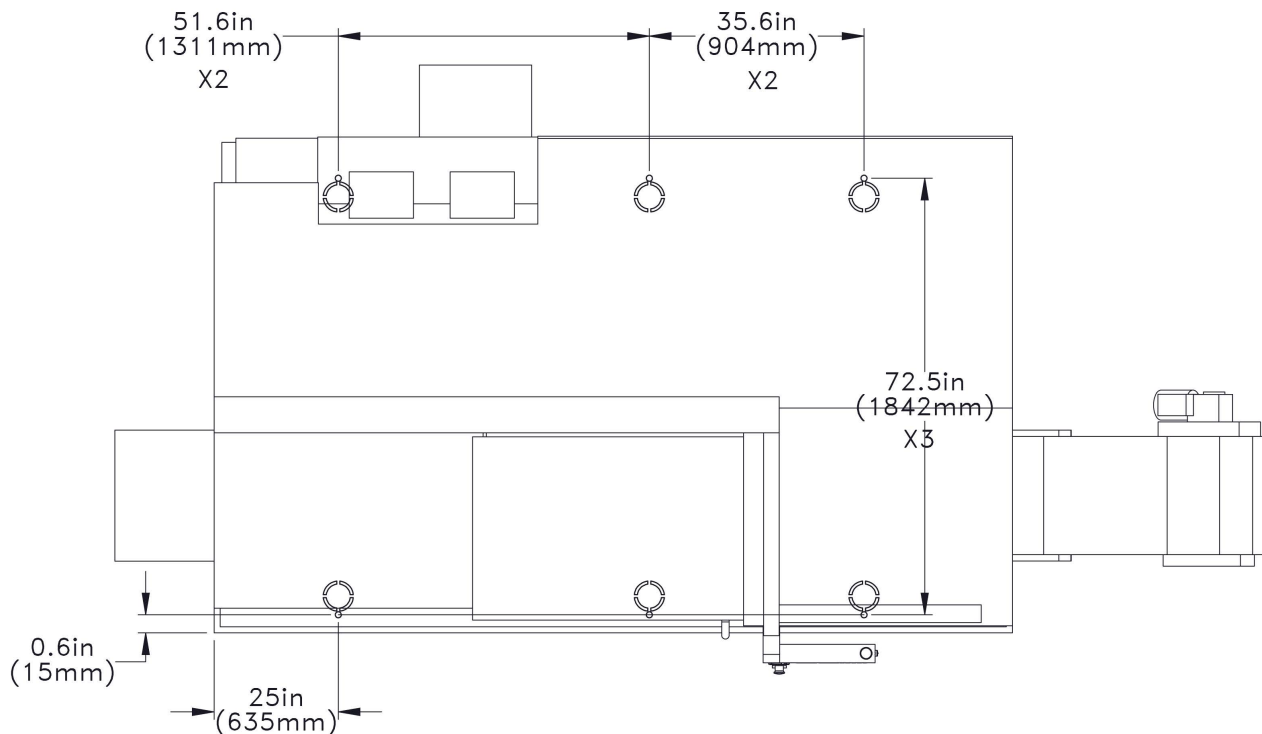

For precise locations and specifications please use template in Anchoring Kit found at Haascnc.com

Height Breakdown

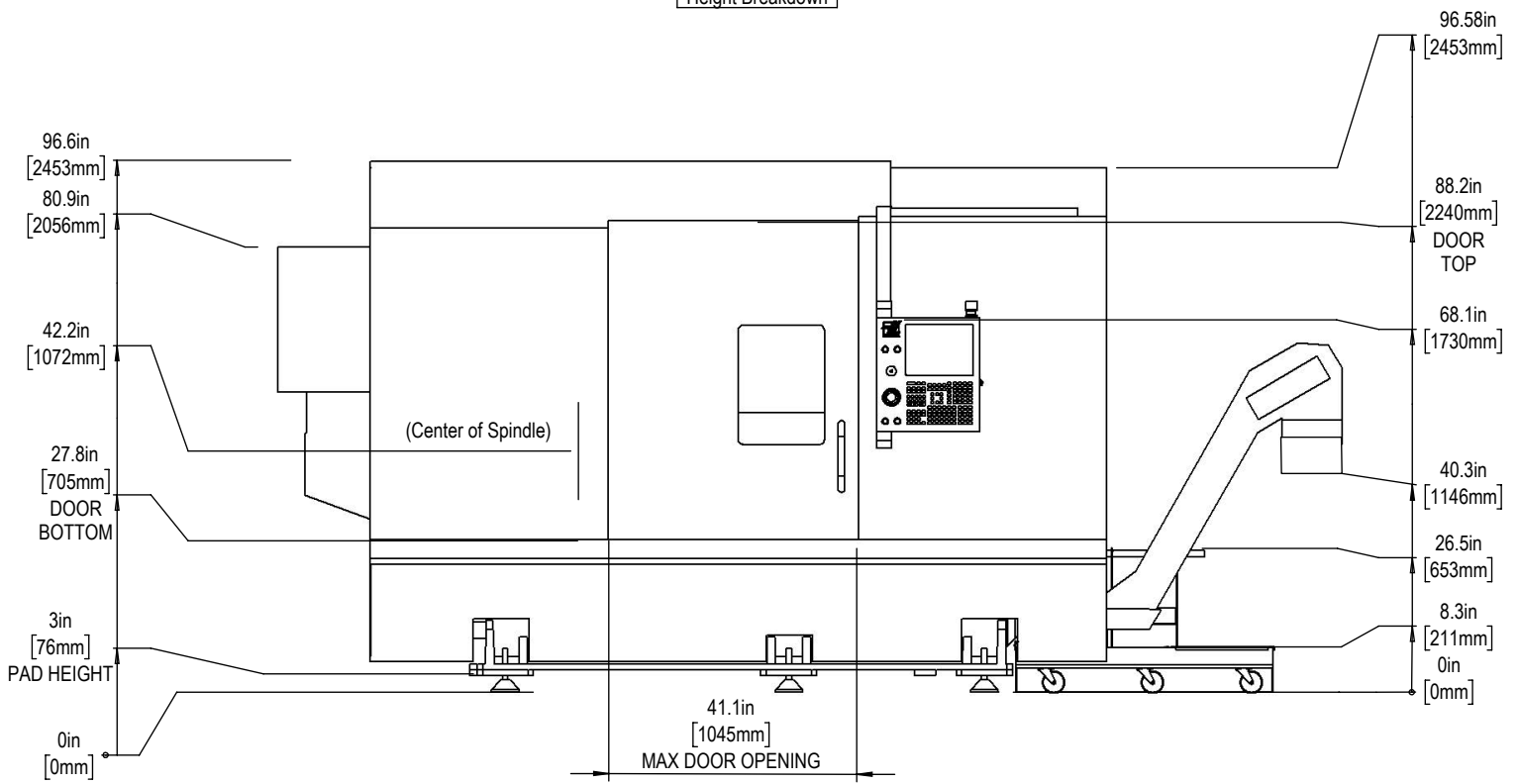

Depth Breakdown

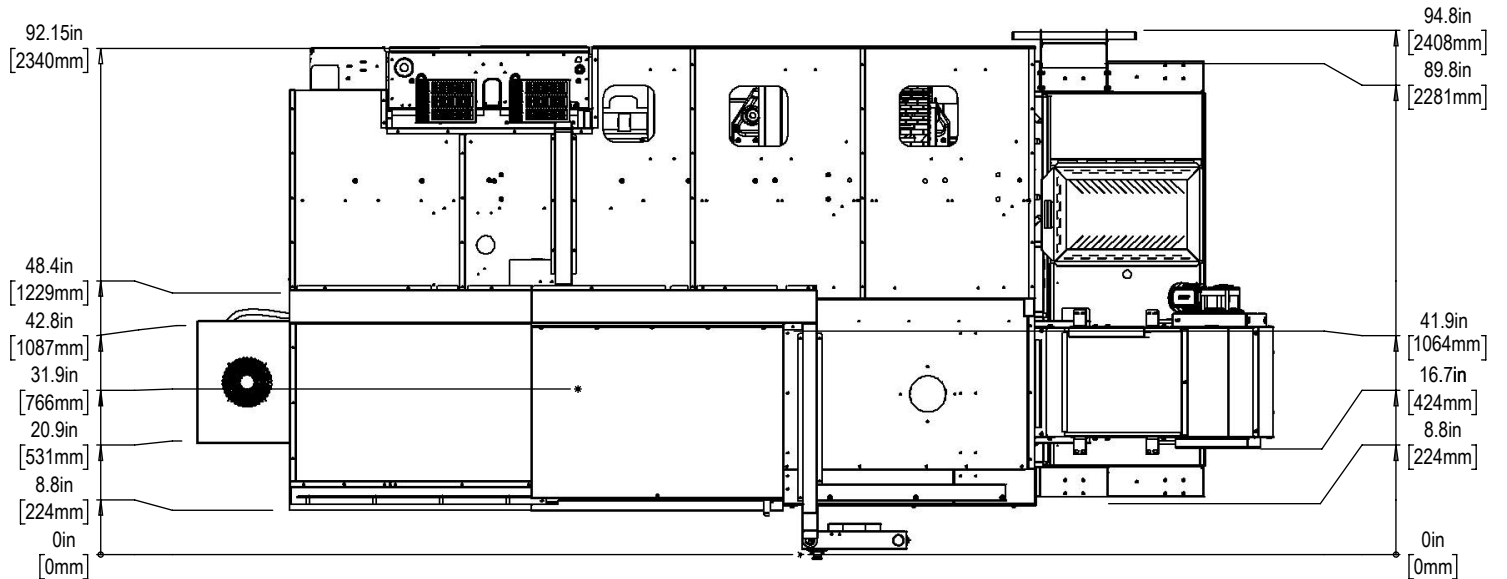



Axis Travel Diagrams

Turning Tool - ID

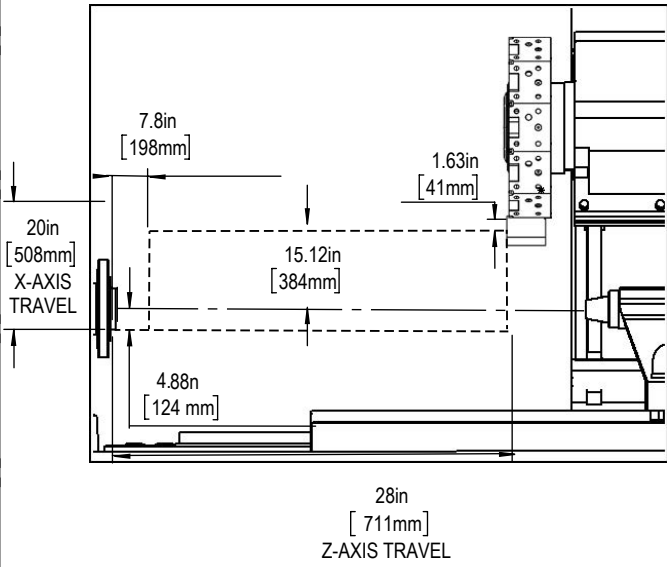

Turning Tool - OD

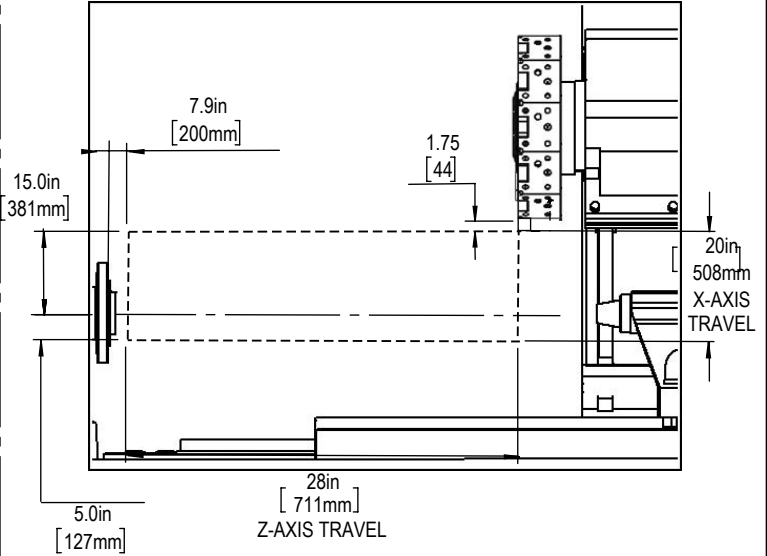

Axis Travel Diagrams

Tailstock Travels

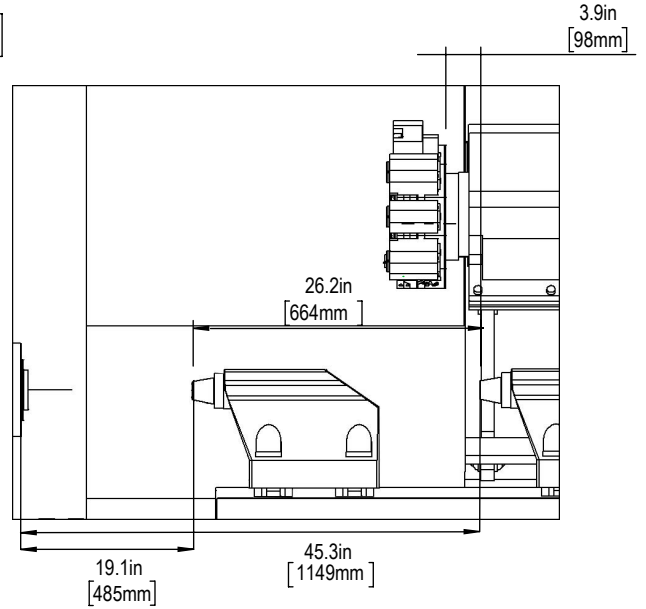

Turning Tool - ID

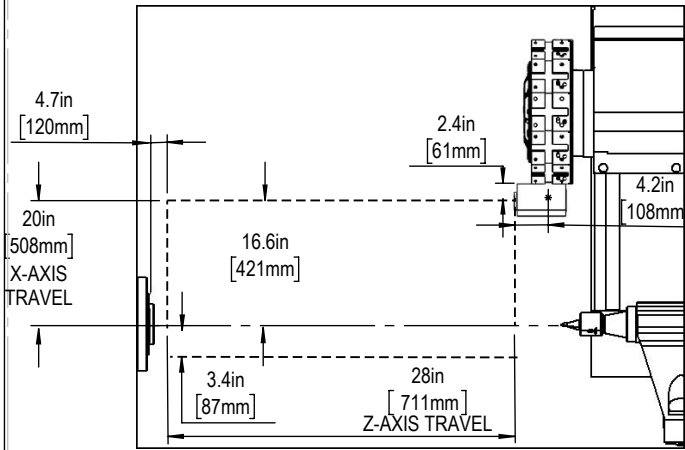

Turning Tool - OD

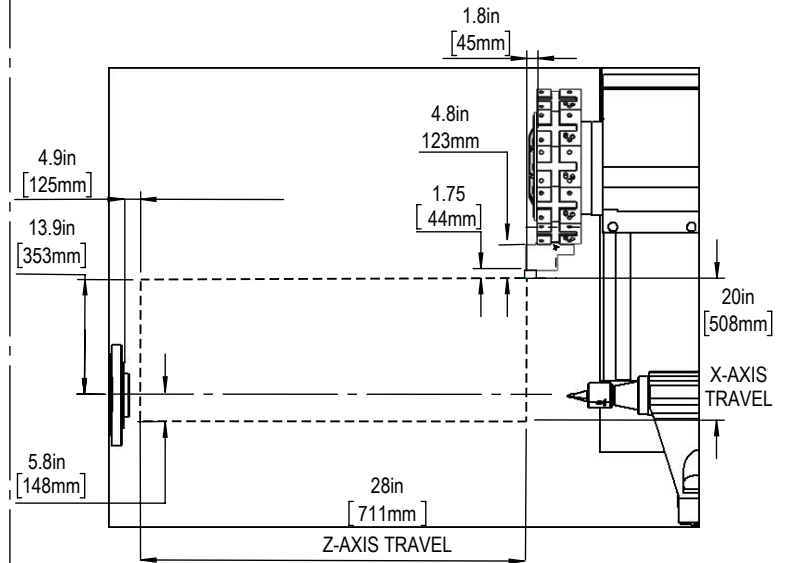

Optional Live Tooling - BMT75 -STRAIGHT

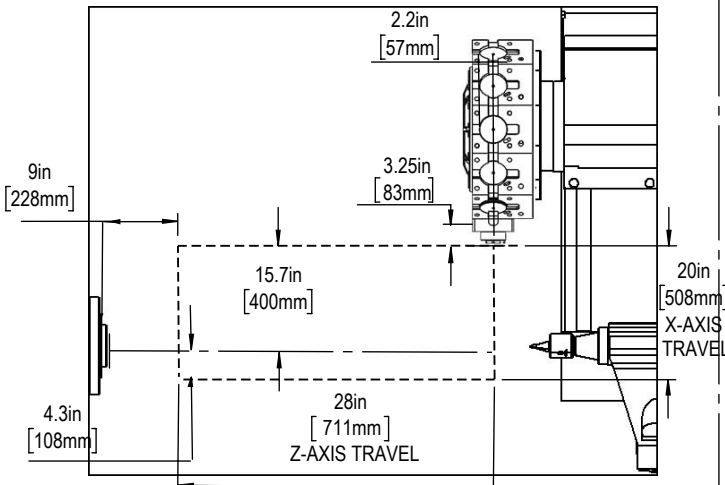

Optional Live Tooling - BMT75-90-DEGREE

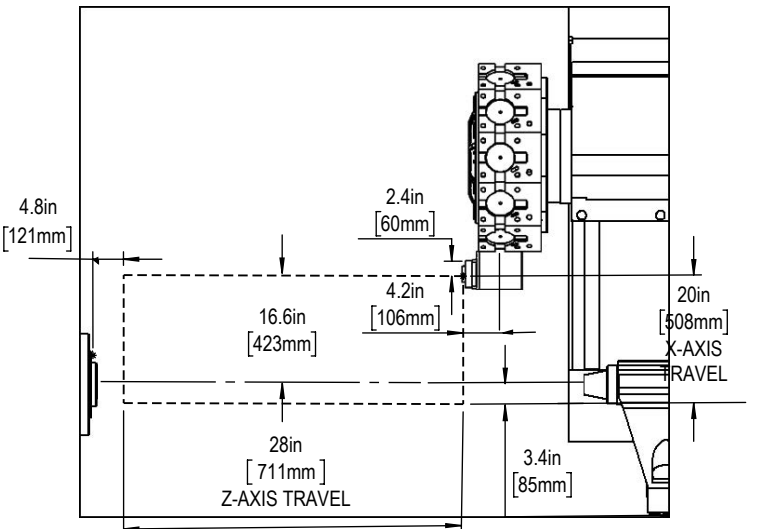

Tool Interference Layout

Standard Chuck

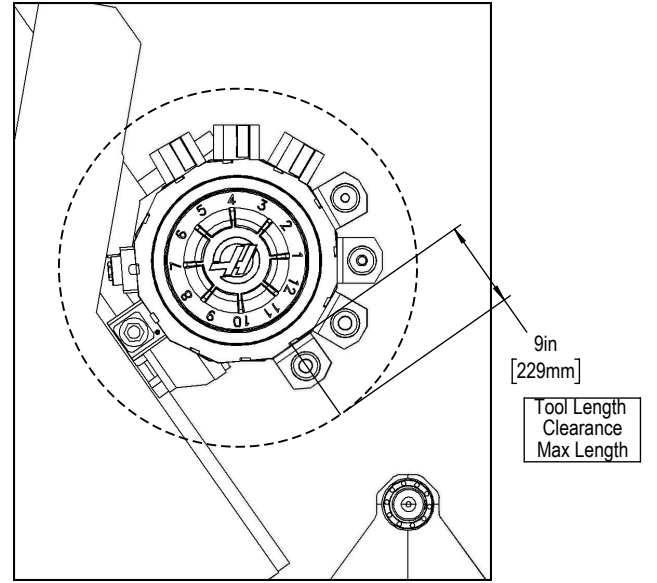
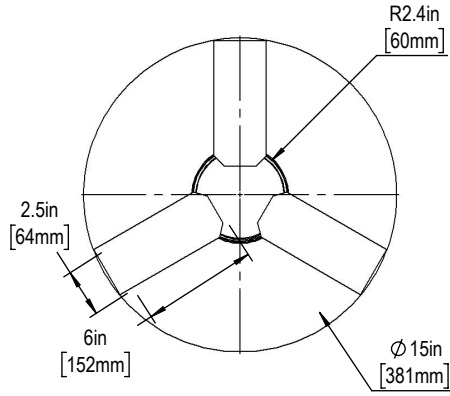
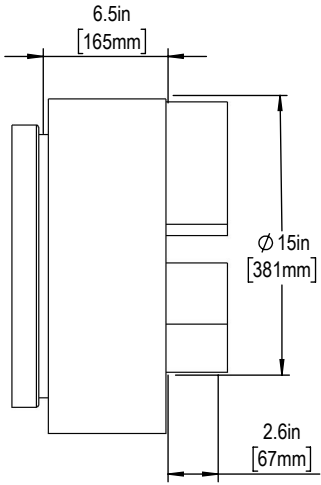

Dimensions may vary per manufacturer

Standard Extended Tool Pocket

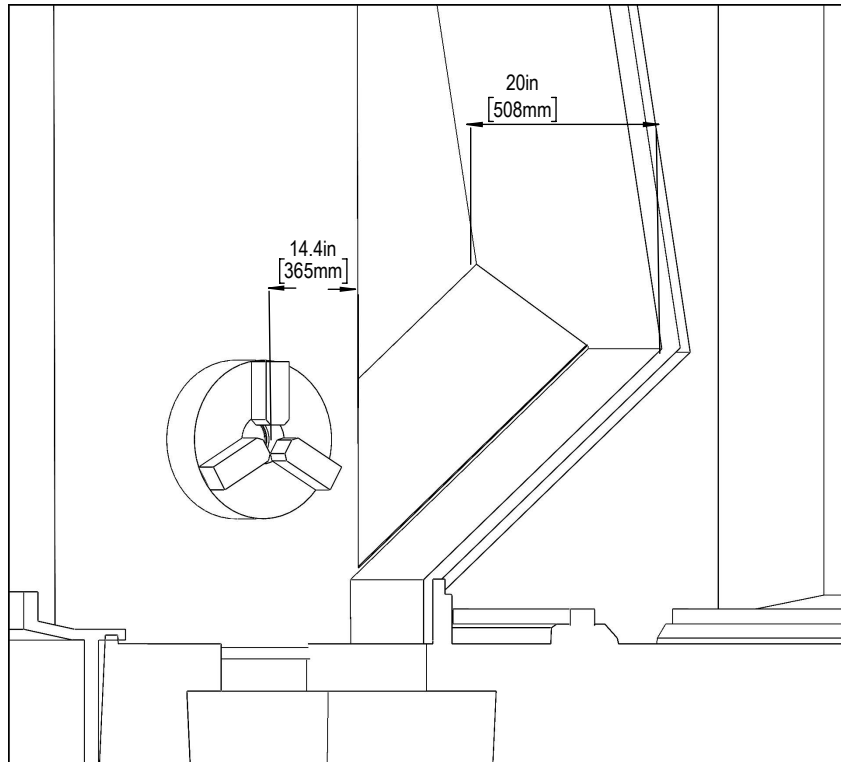

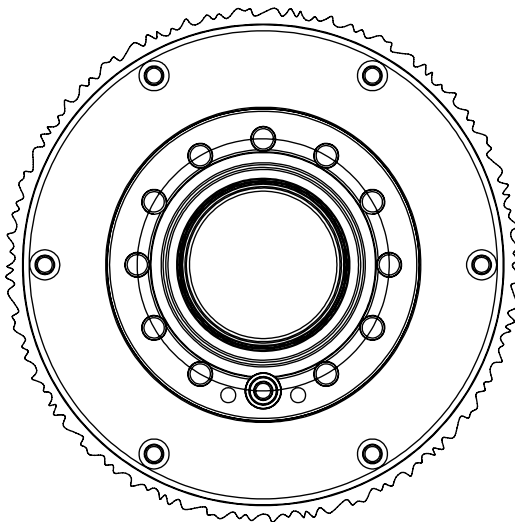
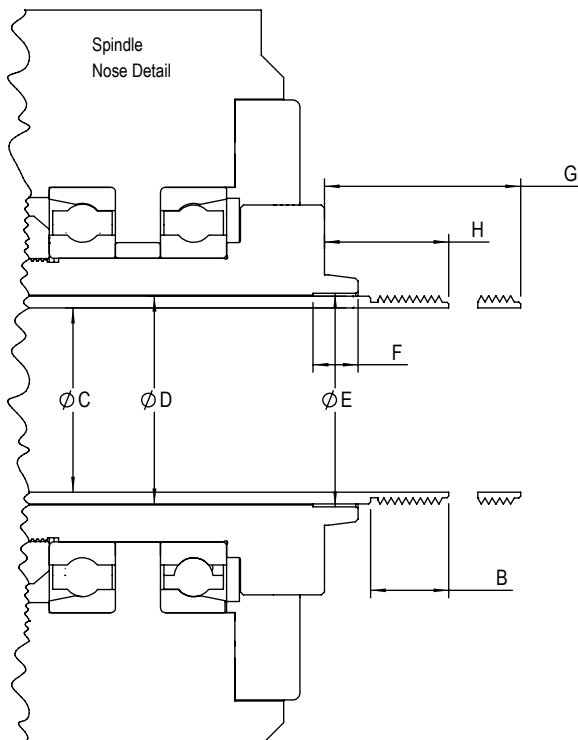
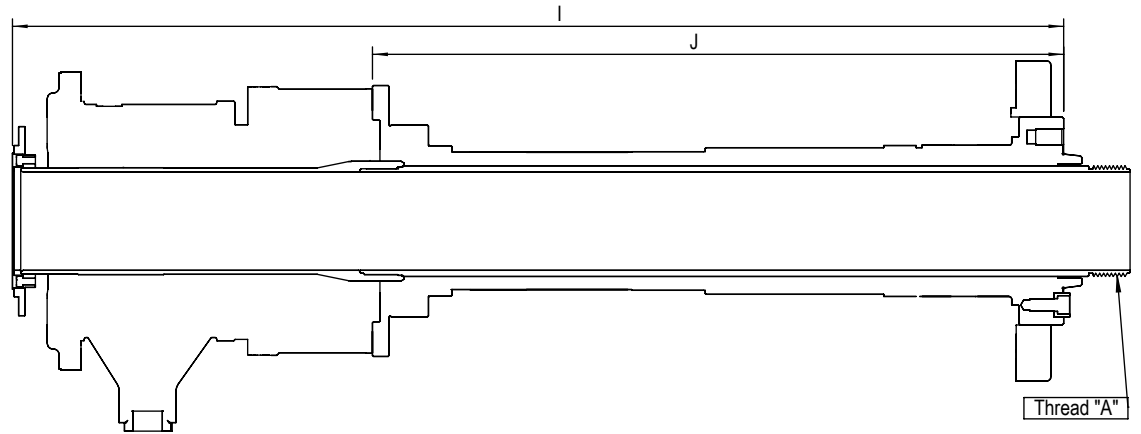

Description	DIMENSION PARAMETER	ST-40S	
		SAE (in)	METRIC (mm)
SPINDLE TYPE		A2-8	
THREAD TYPE	A	M115 X 2.0	
INTERNAL OR EXTERNAL		EXTERNAL	
LENGTH OF THREAD	B	1.42	36.08
DRAWTUBE INTERNAL \varnothing	C	4.23	107.49
DRAWTUBE EXTERNAL \varnothing	D	4.56	115.87
COUNTERBORE INTERNAL \varnothing	E	N/A	N/A
COUNTERBORE DEPTH	F	N/A	N/A
DRAWTUBE EXTENDED	G	3.13	79.5
DRAWTUBE RETRACTED	H	1.75	44.5
SPINDLE FACE TO BACK OF UNION	I	41.0	1041
SPINDLE FACE TO UNION ADAPTOR	J	30.9	785

*Due to vendor variations discretion should be taken to verify validity of provided dimensions

SPINDLE NOSE DETAILS PER AMERICAN STANDARD BULLETIN ASA B5.9 (ANSI)

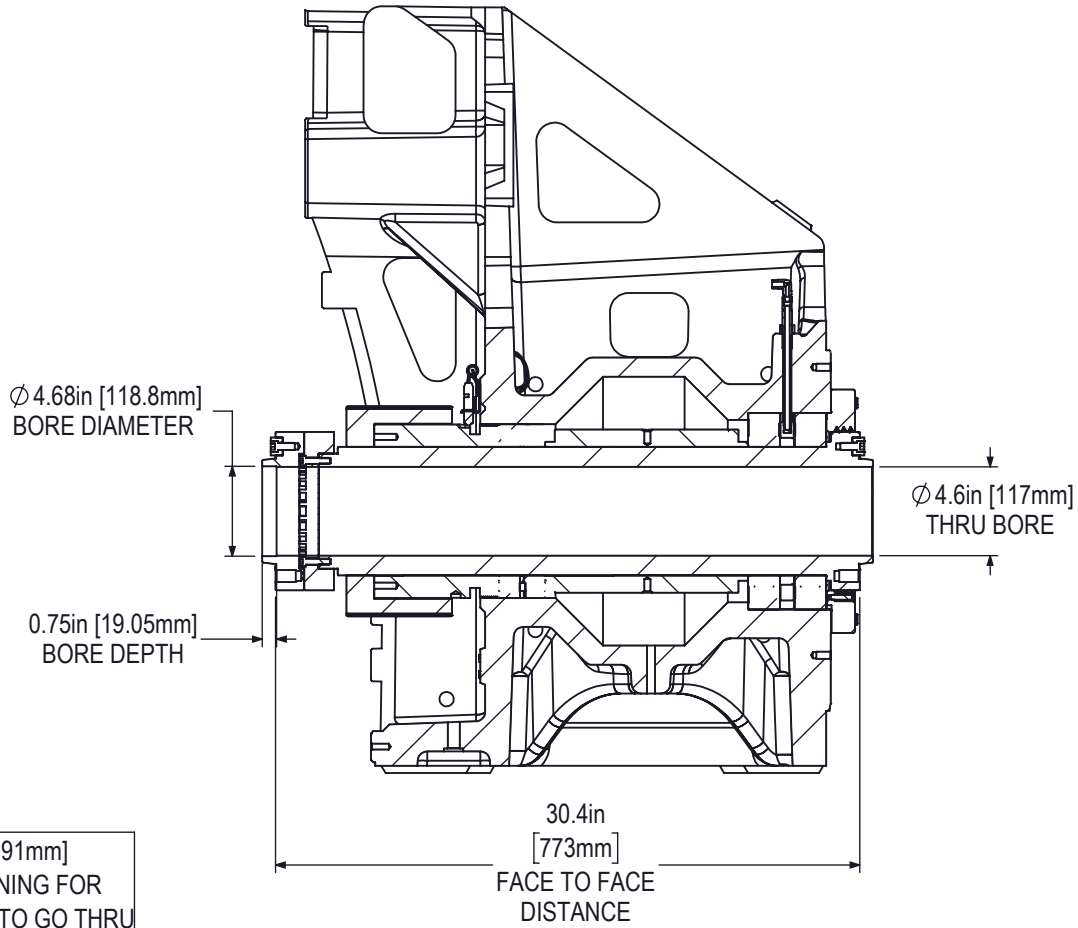

7.52in [191mm]
DOOR OPENING FOR
LONG PARTS TO GO THRU

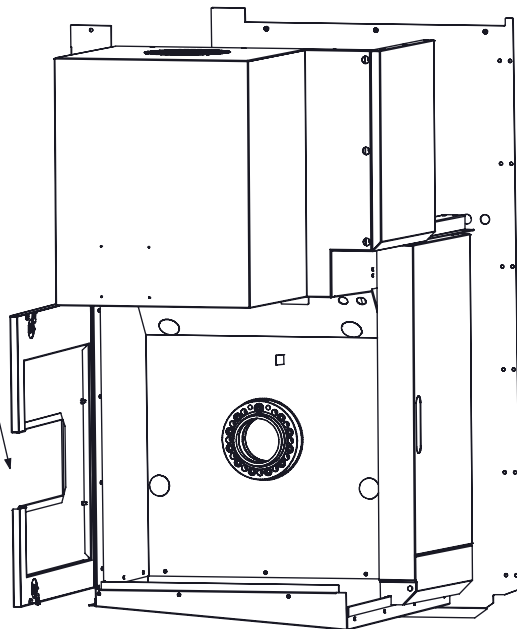

MAXIMUM CHUCK AND PART CLEARANCE
DIAMETER INSIDE OF THE ENCLOSURE
24in [610mm]

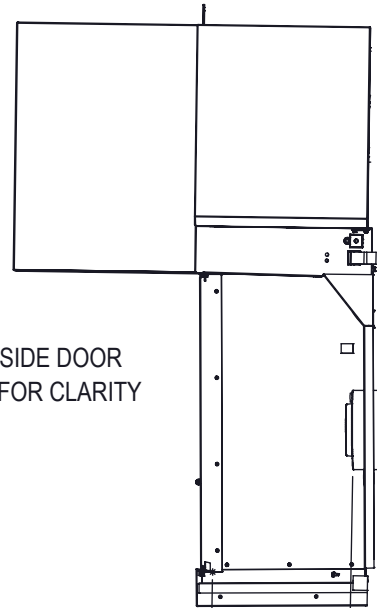

REAR AND SIDE DOOR
REMOVED FOR CLARITY

14.5in [368mm]
MAXIMUM PART LENGTH
INSIDE OF THE ENCLOSURE
WITH DOORS CLOSED

*DUE TO VENDOR VARIATIONS AND TOLERANCE BUILD-UP, HAAS STRONGLY RECCOMENDS MEASURING DIRECTLY ON THE MACHINE