

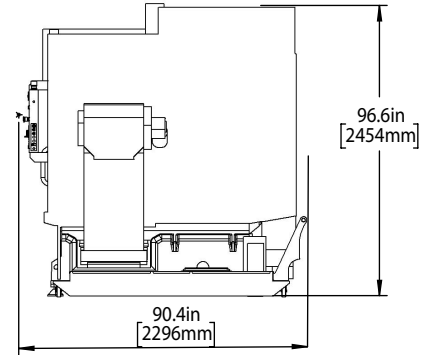

Installed Dimensions

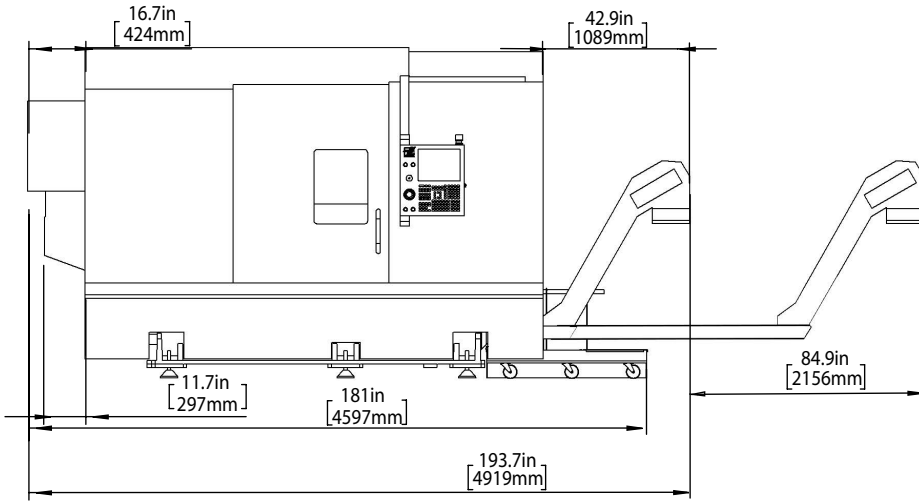
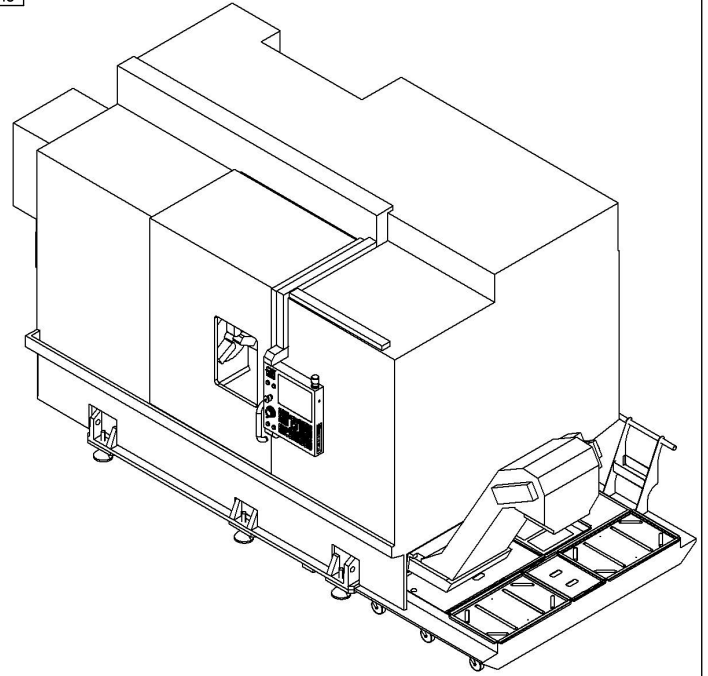
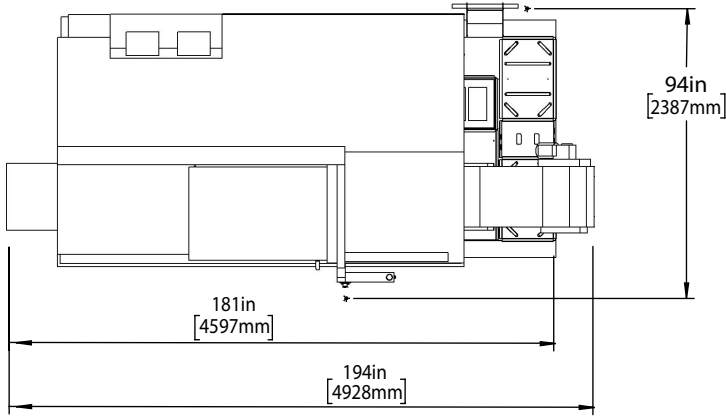

Shipping Dimensions

*All Height Dimensions Based on Suggested Leveling Pad Height

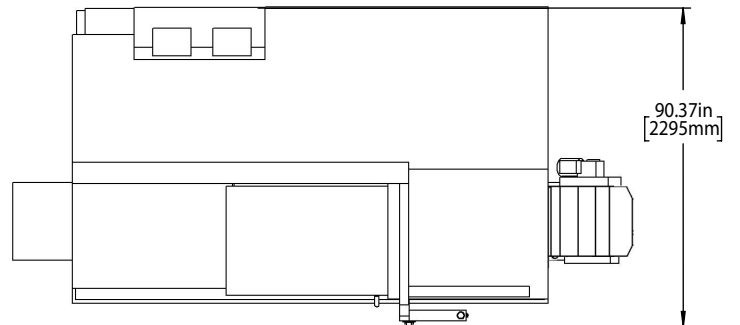
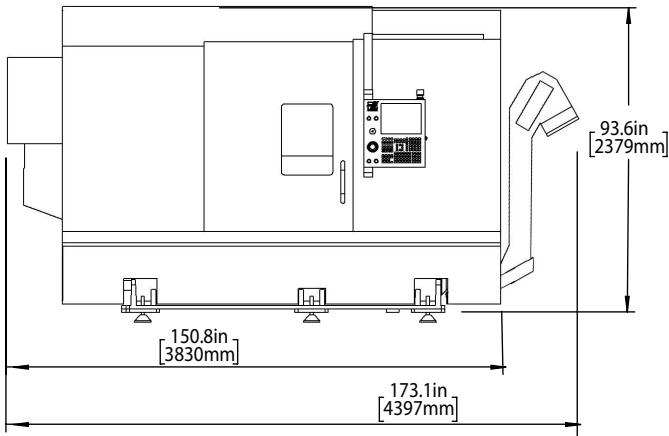



Air & Power

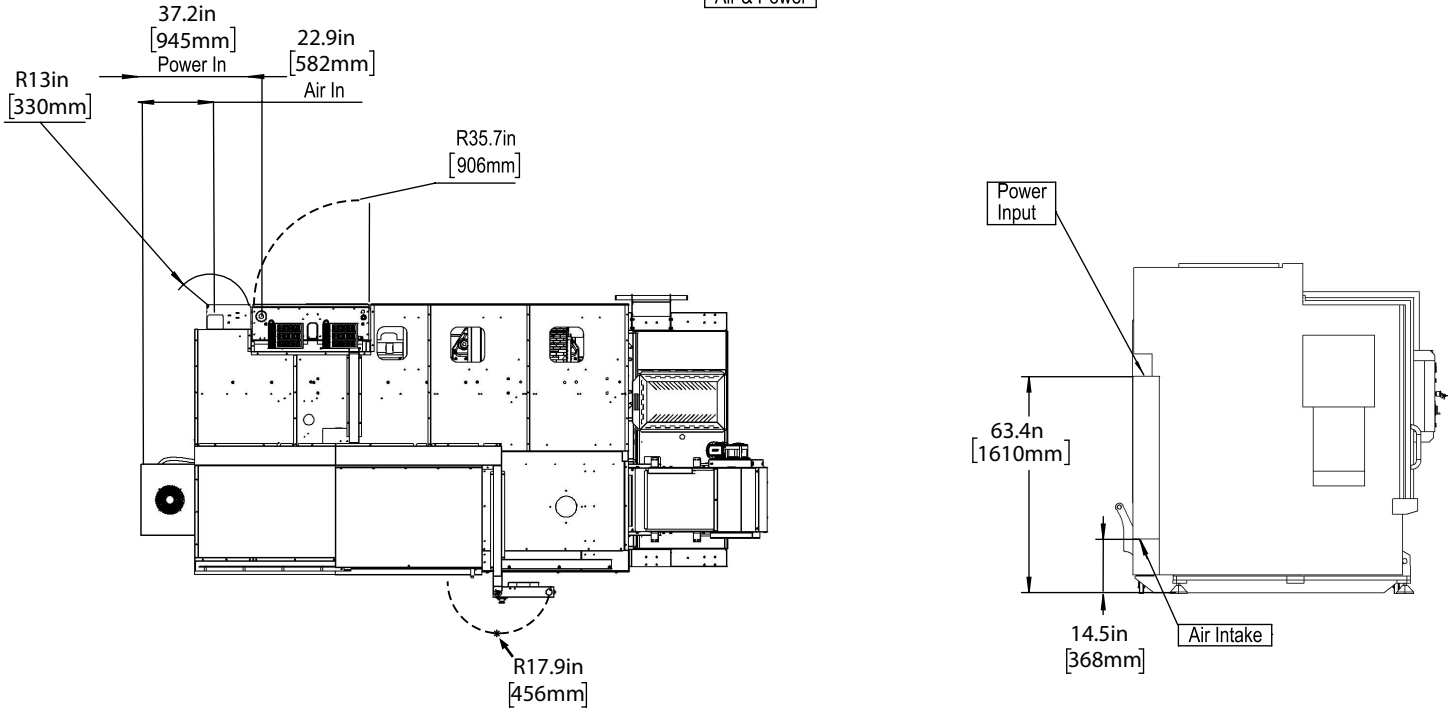

Maintain 3 feet [915mm] clearance to the nearest obstruction around all sides of machine perimeter for maintenance access

Note:
Machine must be placed on one continuous concrete slab. Slab should extend 12in [305mm] beyond anchor holes in all directions

Anchor Pattern

Anchor Hole Detail
 Ø 0.625in[25mm]
 ▽ 2.0in[50mm]-
 ▽ 2.25in[57mm]

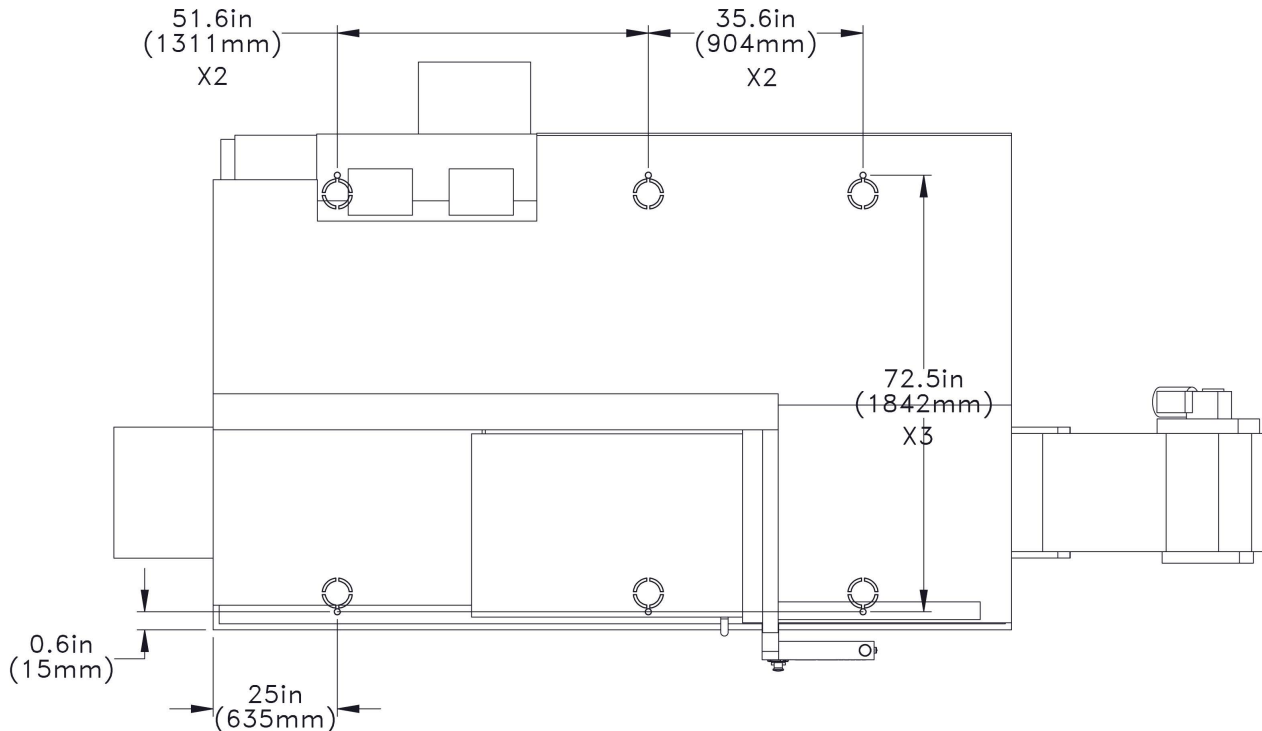

For precise locations and specifications please use template in Anchoring Kit found at Haascnc.com

Height Breakdown

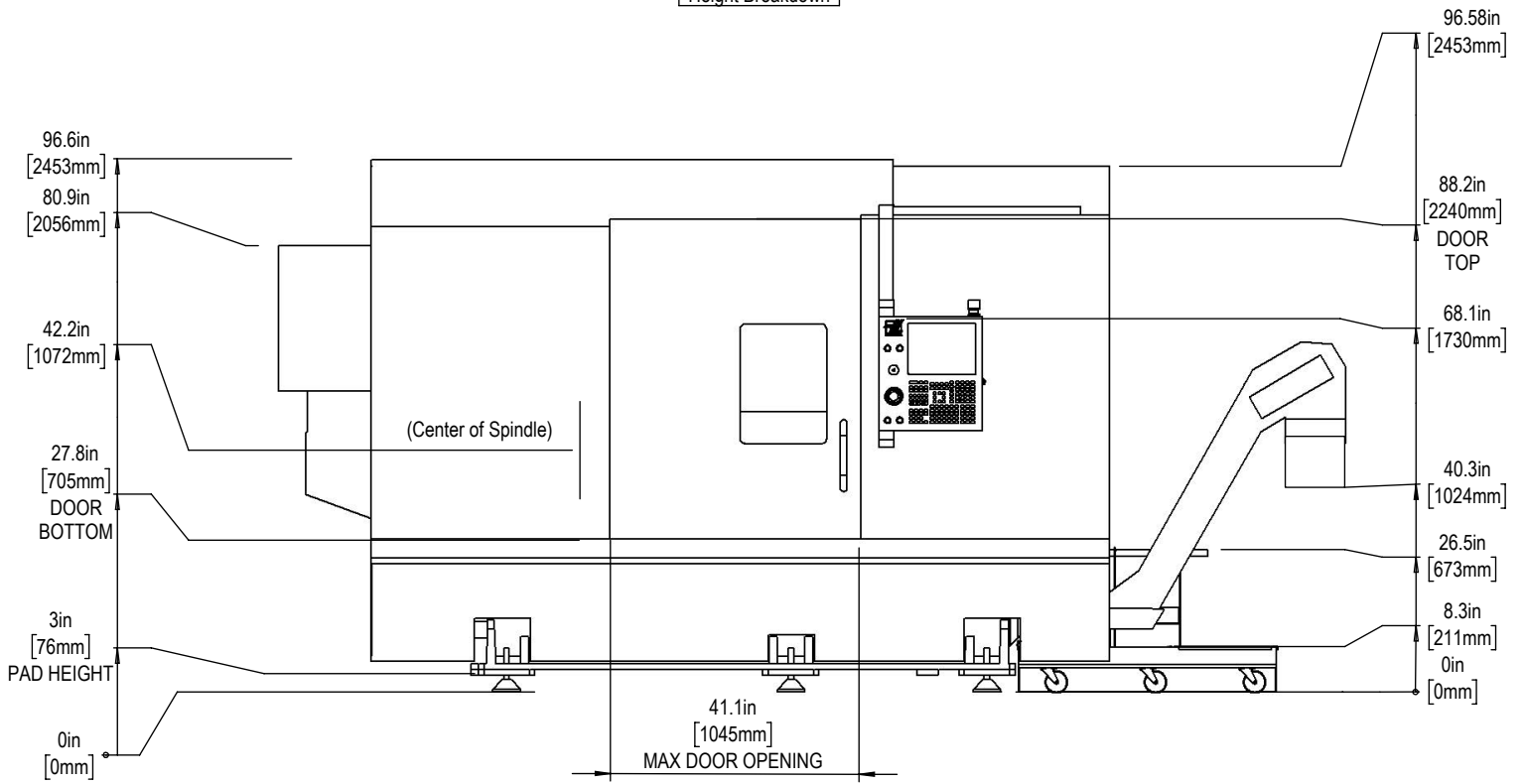

Depth Breakdown

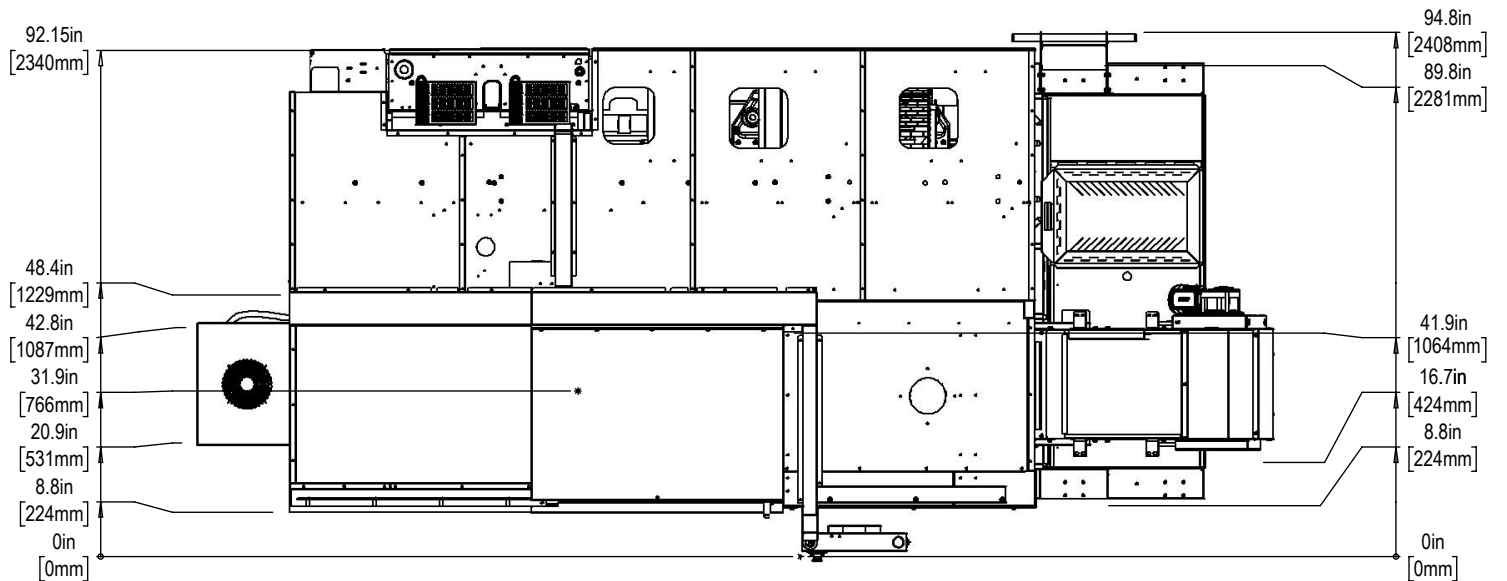



Axis Travel Diagrams

Turning Tool - ID

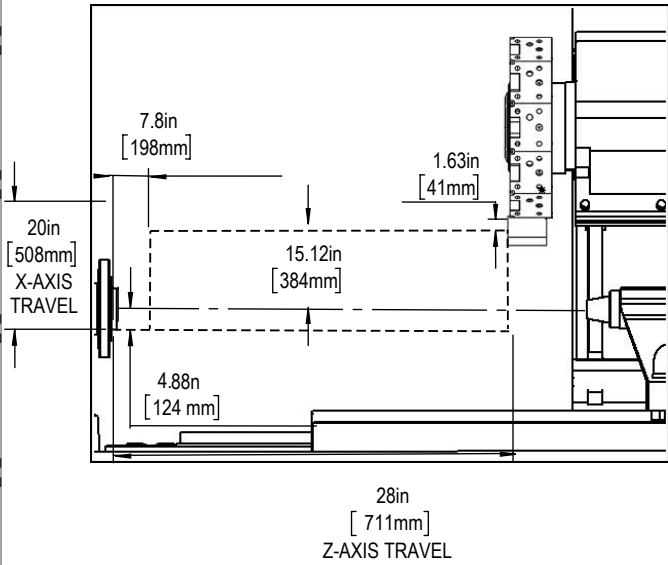

Turning Tool - OD

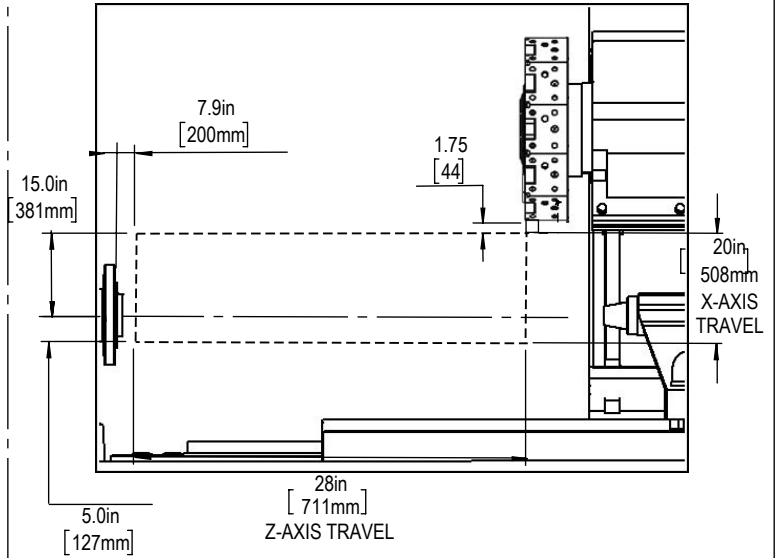

Axis Travel Diagrams

Tallstock Travels

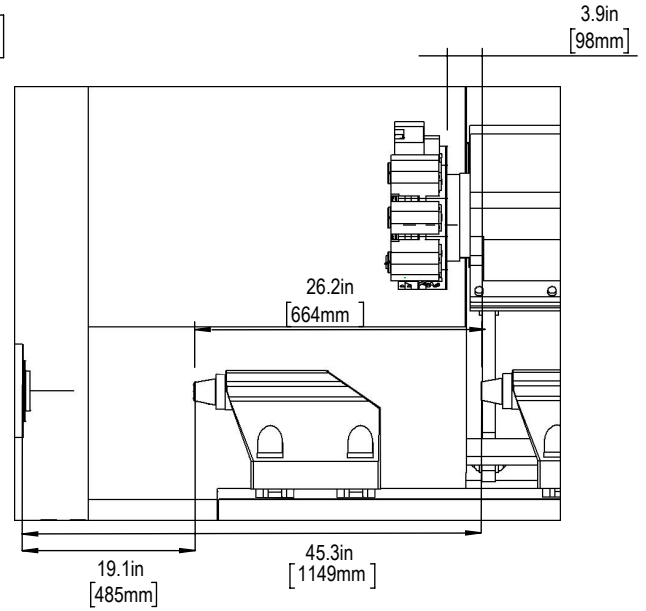

Turning Tool - ID

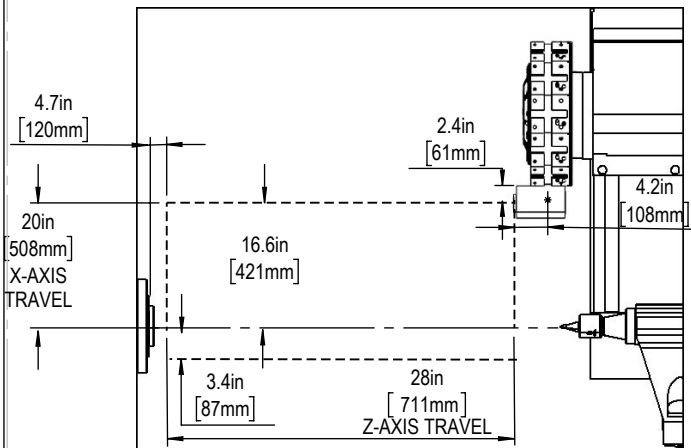

Turning Tool - OD

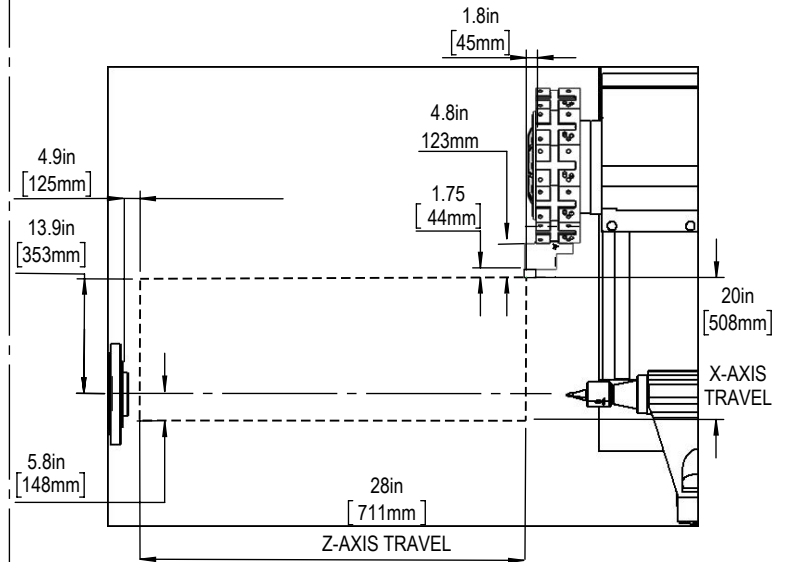

Optional Live Tooling - BMT75-STRAIGHT

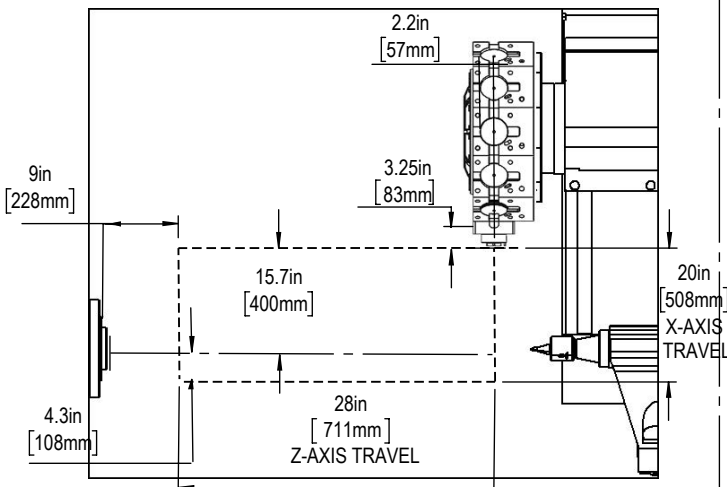

Optional Live Tooling - BMT75-90-DEGREE

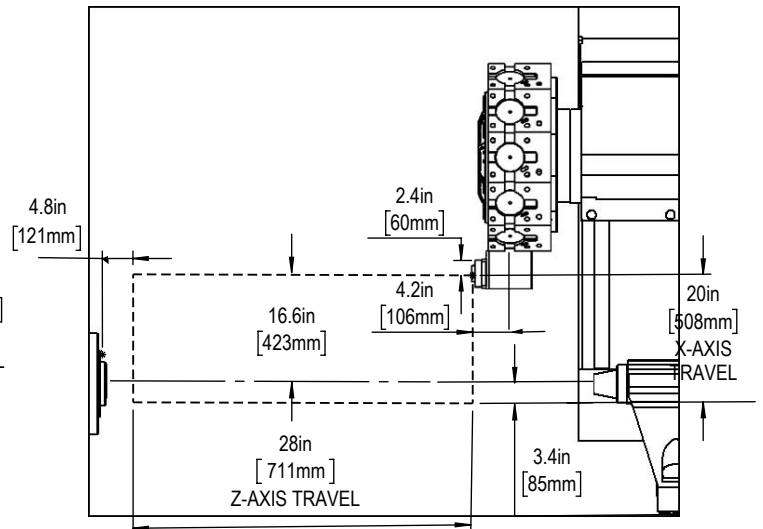

Tool Interference Layout

Optional Chuck

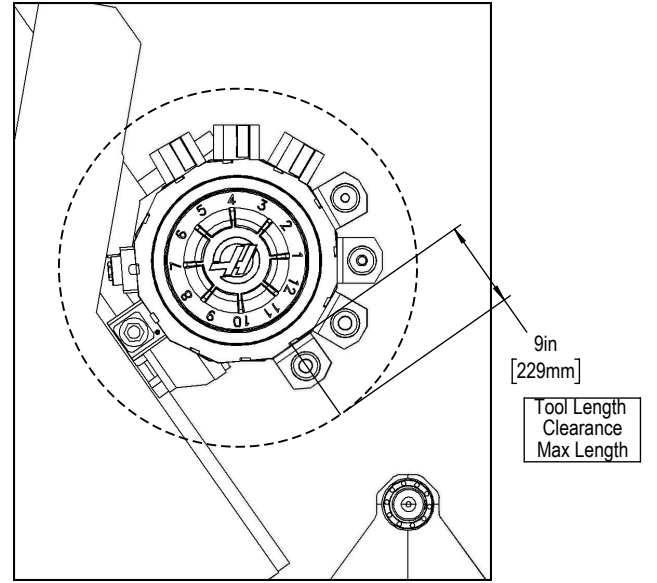
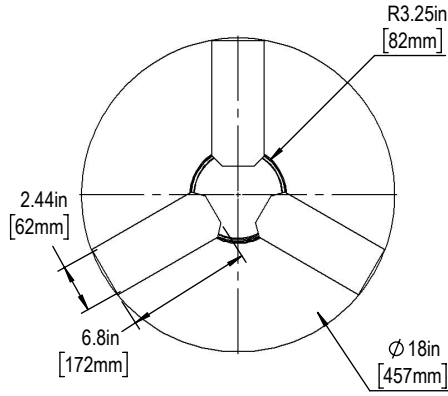
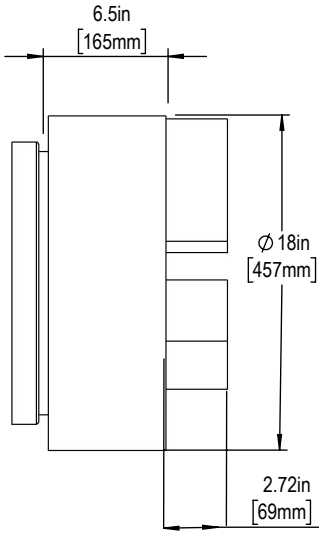

Dimensions may vary per manufacturer

Standard Extended Tool Pocket

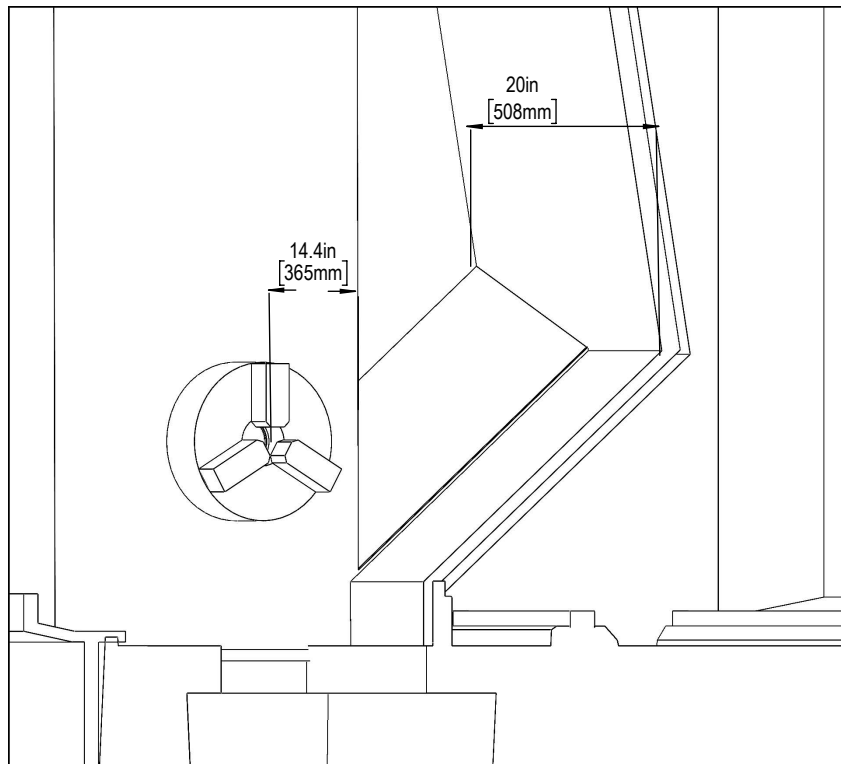

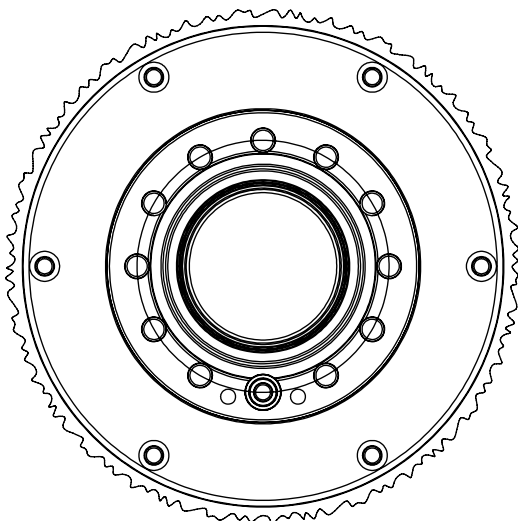
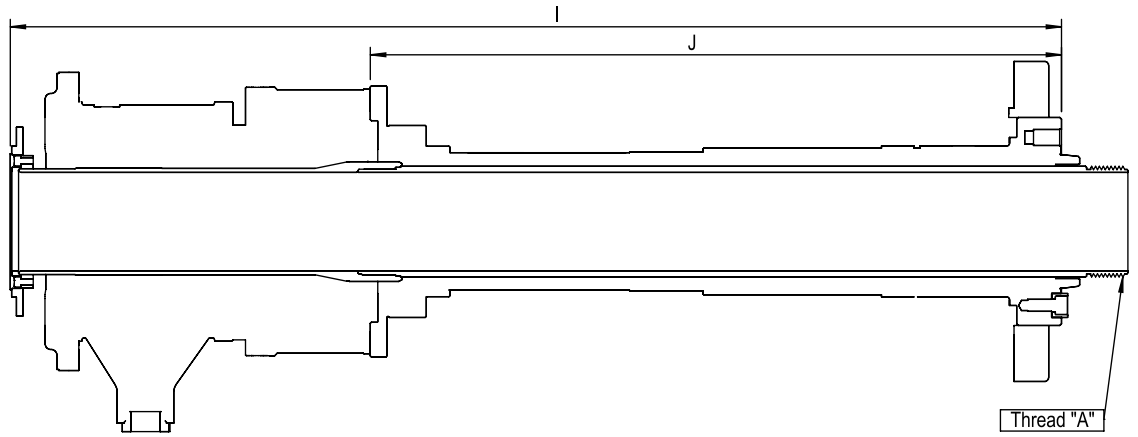

Description	DIMENSION PARAMETER	ST-45S	
		SAE (in)	METRIC (mm)
SPINDLE TYPE		A2-11	
THREAD TYPE	A	M175 X 3.0	
INTERNAL OR EXTERNAL		EXTERNAL	
LENGTH OF THREAD	B	3.03	76.96
DRAWTUBE INTERNAL Ø	C	6.51	165.35
DRAWTUBE EXTERNAL Ø	D	7.02	178.31
COUNTERBORE INTERNAL Ø	E	N/A	N/A
COUNTERBORE DEPTH	F	N/A	N/A
DRAWTUBE EXTENDED	G	3.02	76.71
DRAWTUBE RETRACTED	H	1.84	46.74
SPINDLE FACE TO BACK OF UNION	I	48.3	1226.82
SPINDLE FACE TO UNION ADAPTOR	J	32.7	830.58

*Due to vendor variations discretion should be taken to verify validity of provided dimensions

SPINDLE NOSE DETAILS PER AMERICAN STANDARD BULLETIN ASA B5.9 (ANSI)

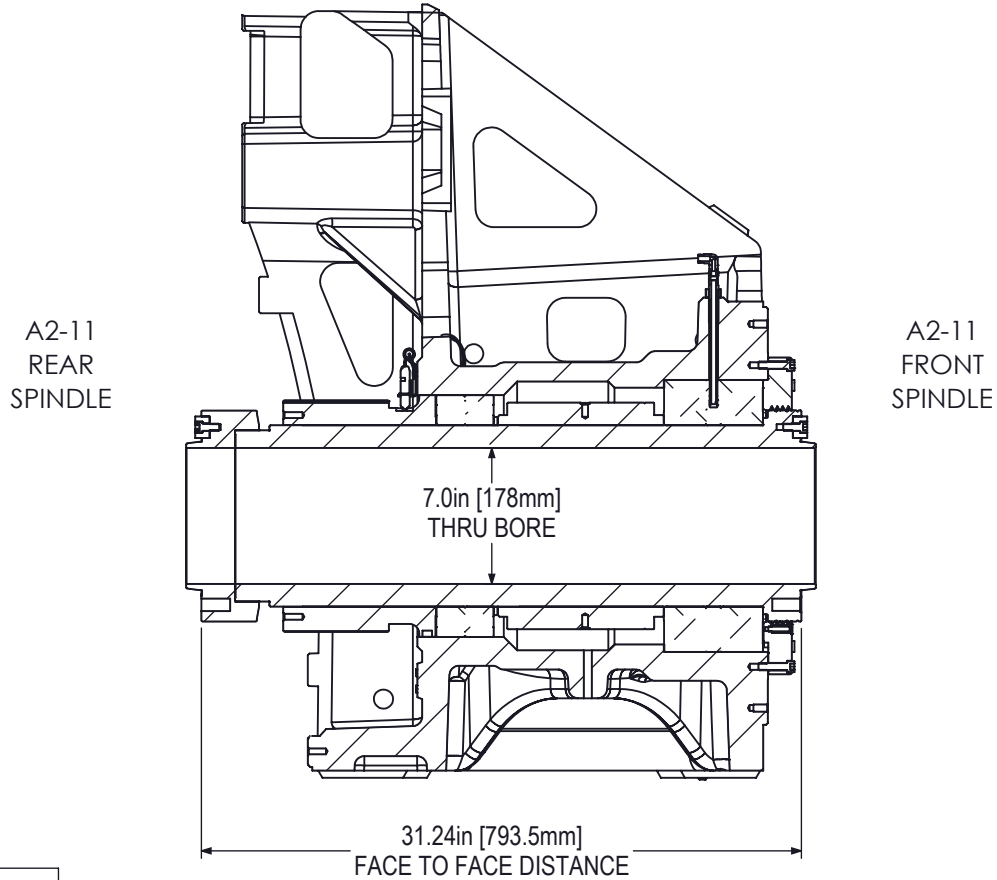

7.52in [191mm]
DOOR OPENING FOR
LONG PARTS TO GO THRU

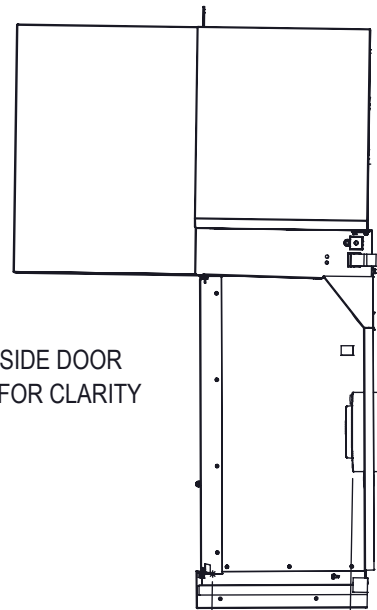
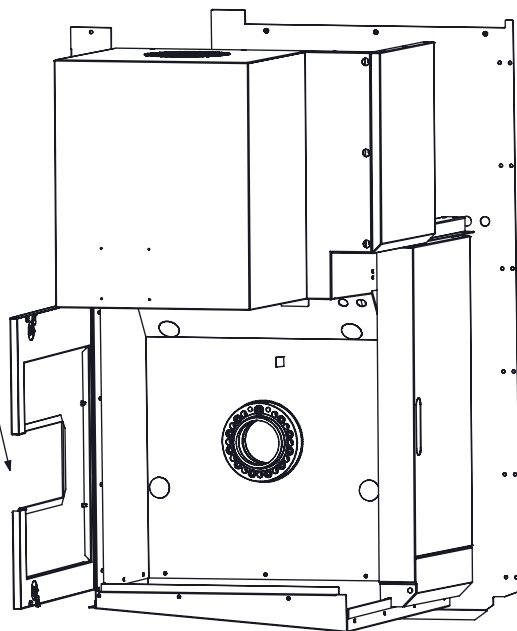

14.5in [368mm]
MAXIMUM PART LENGTH
INSIDE OF THE ENCLOSURE
WITH DOORS CLOSED

*DUE TO VENDOR VARIATIONS AND TOLERANCE BUILD-UP, HAAS STRONGLY RECCOMENDS MEASURING DIRECTLY ON THE MACHINE