

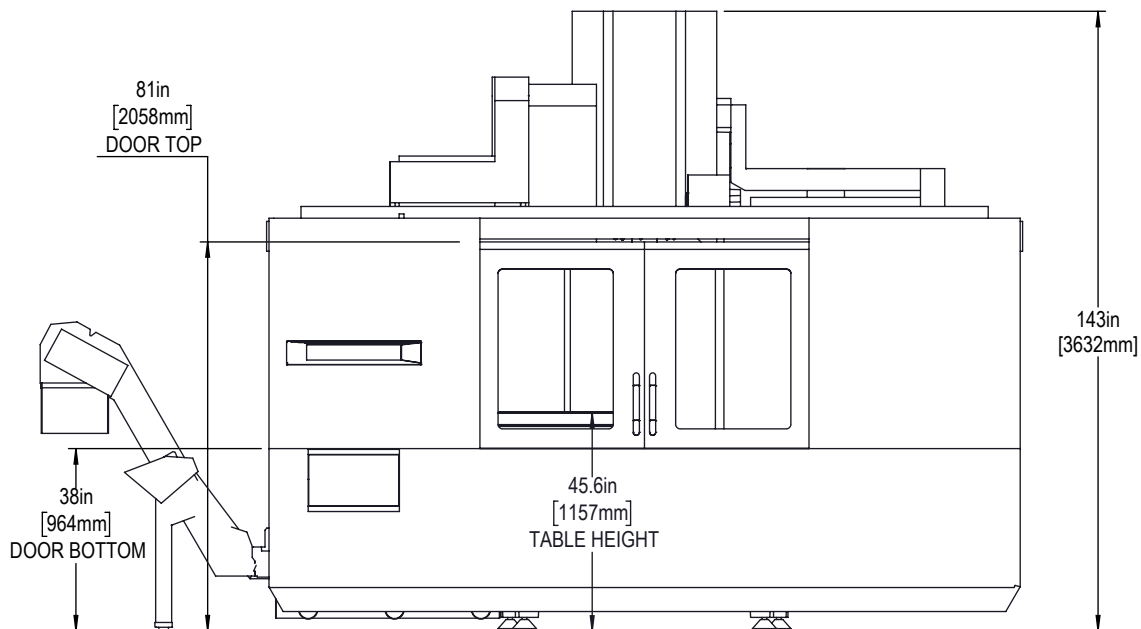

FRONT VIEW - OPERATIONAL HEIGHT



REFER TO THE INSTALLATION INSTRUCTIONS FOR STEP BY STEP GUIDANCE

TOP VIEW - OPERATIONAL DEPTH AND WIDTH

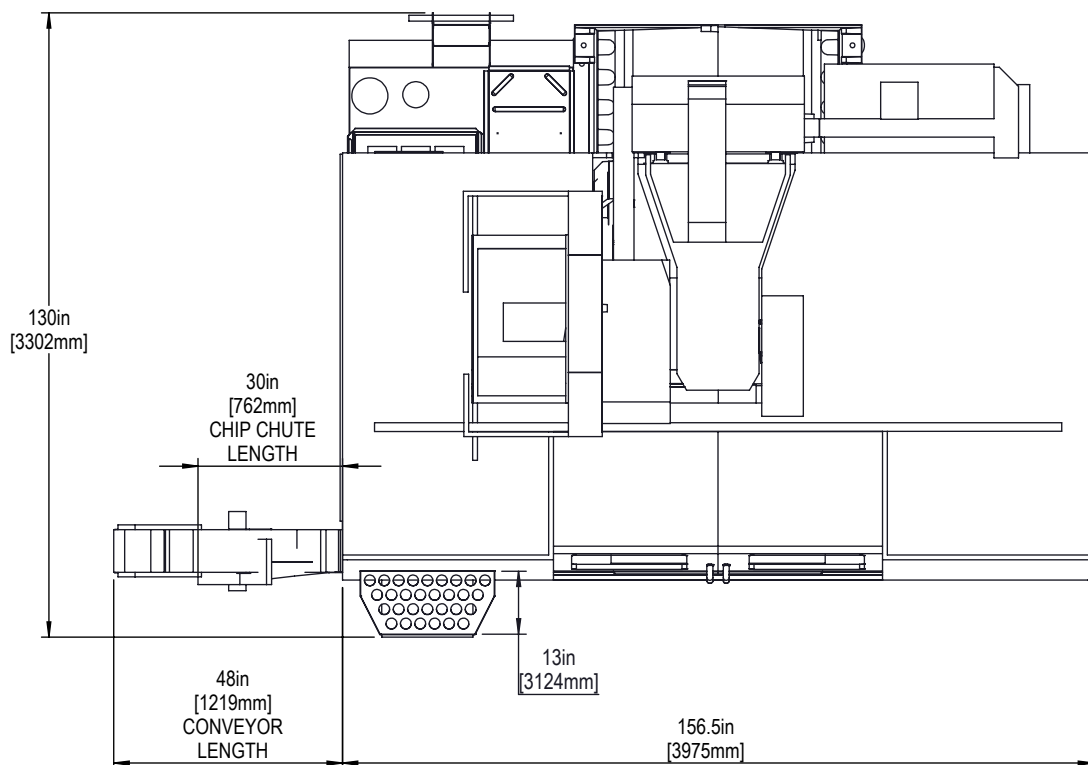



FRONT VIEW

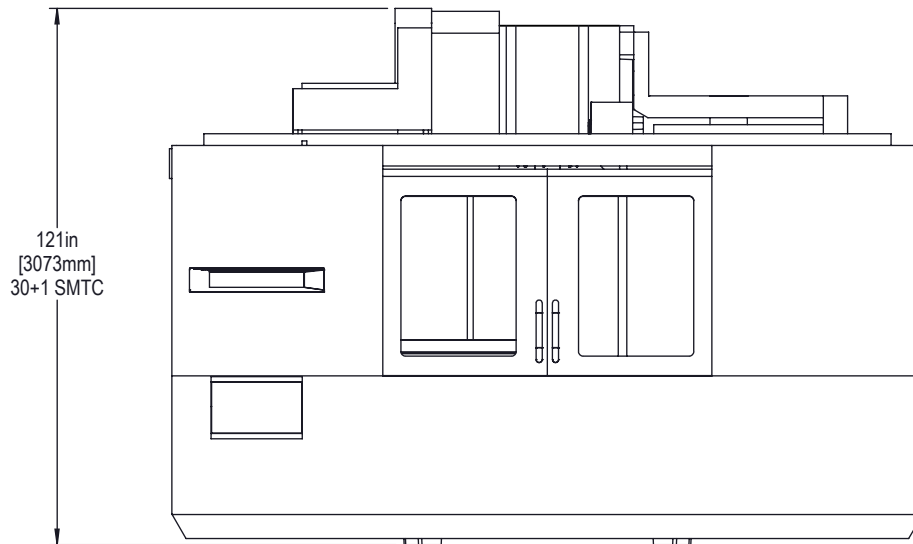

DIMENSION SHOWN IS FROM THE BOTTOM OF THE BASE TO THE TOP OF THE TOOLCHANGER COVER

LEVELING SCREWS AND PADS ARE REMOVED TO REDUCE HEIGHT

TOP VIEW

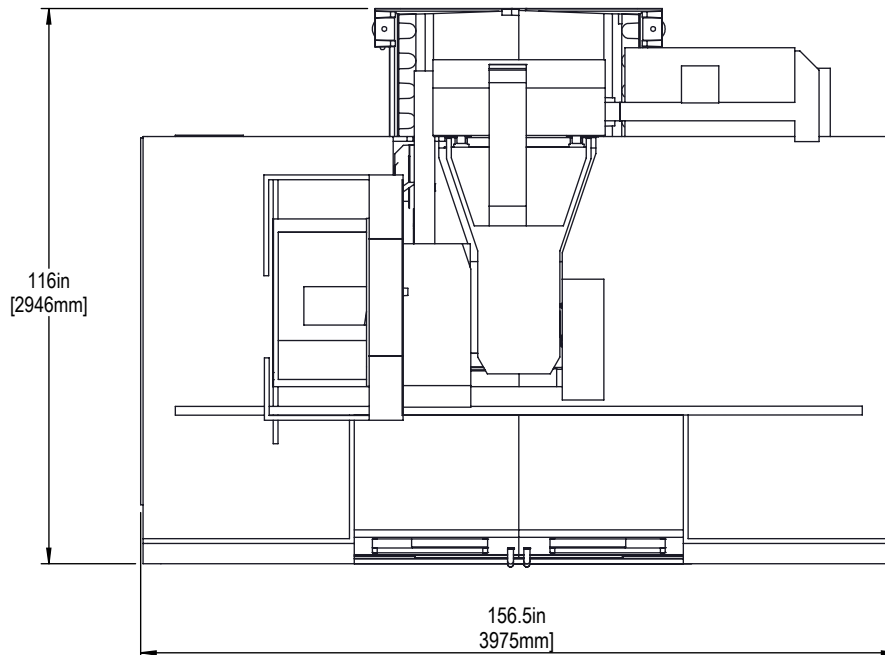
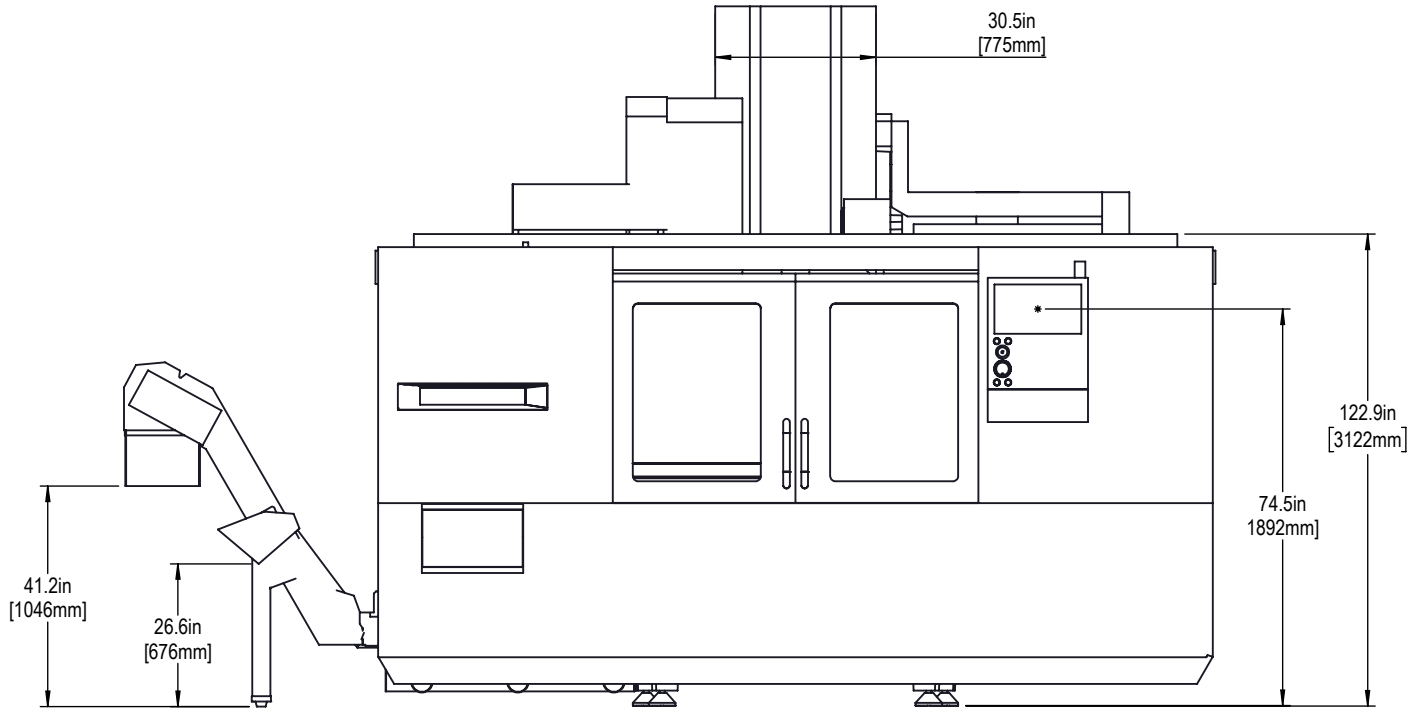

IMAGE SHOWN HAS COOLANT TANK REMOVED TO SHOW THE SMALLEST DEPTH

MACHINE SHIPS WITH CONTROL REMOVED



HEIGHT BREAKDOWNS



DEPTH AND WIDTH BREAKDOWNS

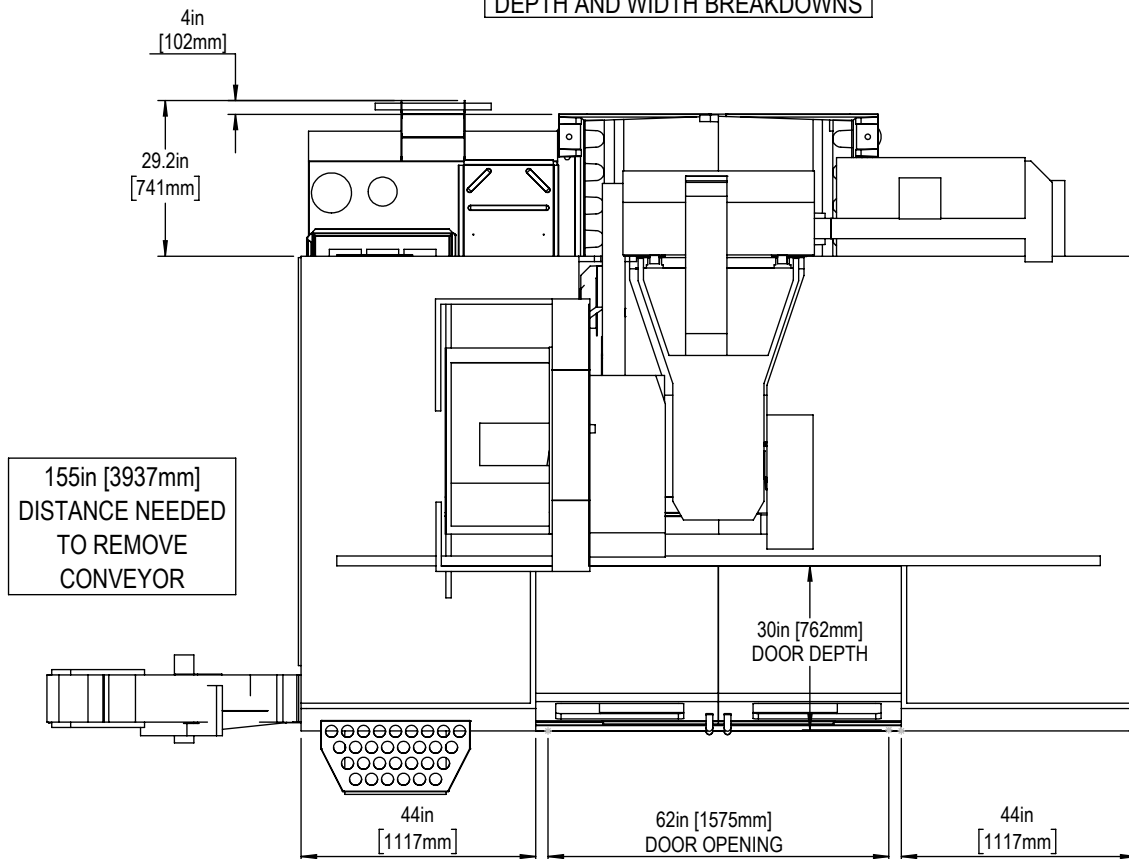



BACK VIEW

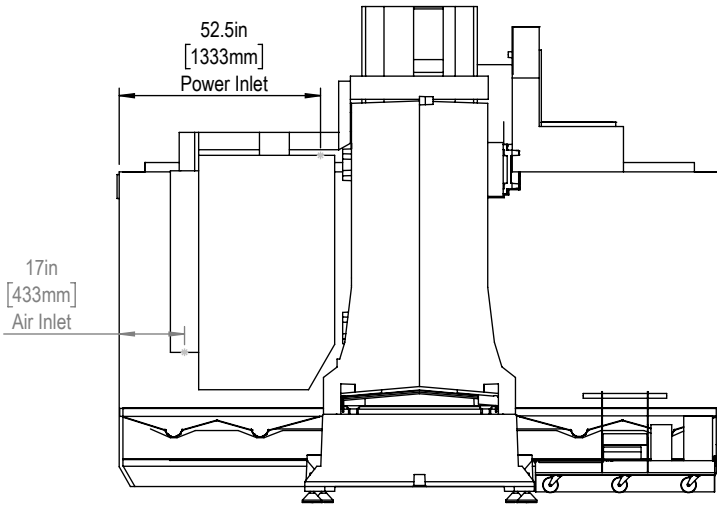

RIGHT SIDE VIEW

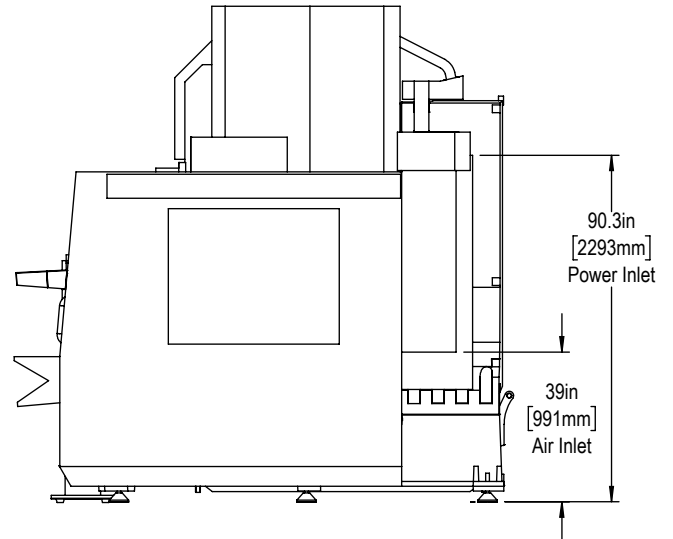

REFER TO MACHINE INSTALLATION INSTRUCTIONS FOR DETAILS

A 36in [914mm] CLEARANCE IS REQUIRED FOR ELECTRICAL CABINET

NOTE: MACHINE MUST BE PLACED ON ONE CONTINUOUS CONCRETE SLAB.
SLAB SHOULD EXTEND 12in [305mm] BEYOND ANCHOR HOLES IN ALL DIRECTIONS

ANCHOR HOLE DETAILS:
 \varnothing 0.62in [16mm]
 ▾ 2in [51mm]
 ▾ 2.25in [57mm]

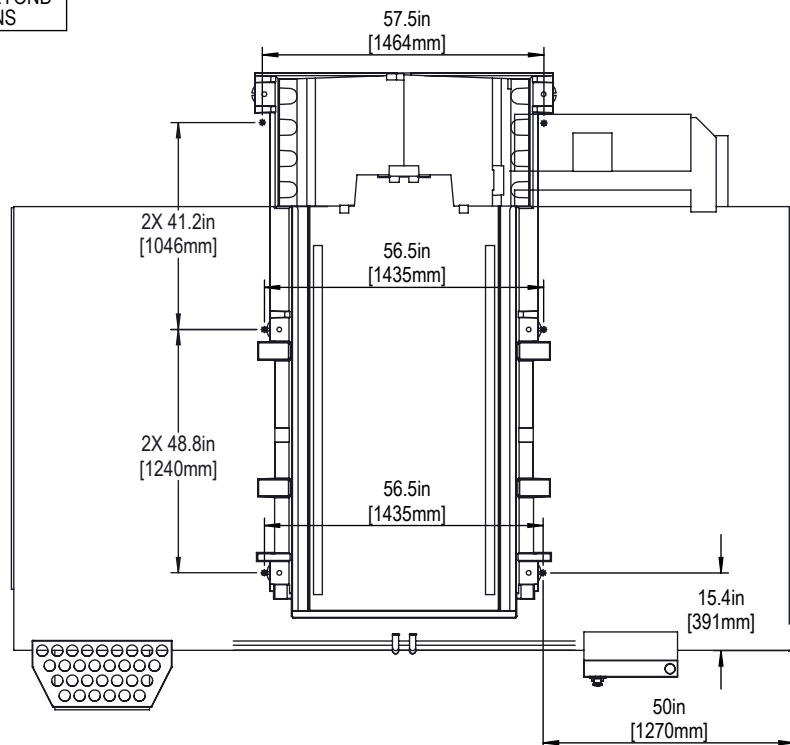

FOR PRECISE DRILLING LOCATIONS PLEASE USE THE TEMPLATE FROM THE MACHINE ANCHORING KIT



X AND Y AXIS TRAVEL & WORK ENVELOPE

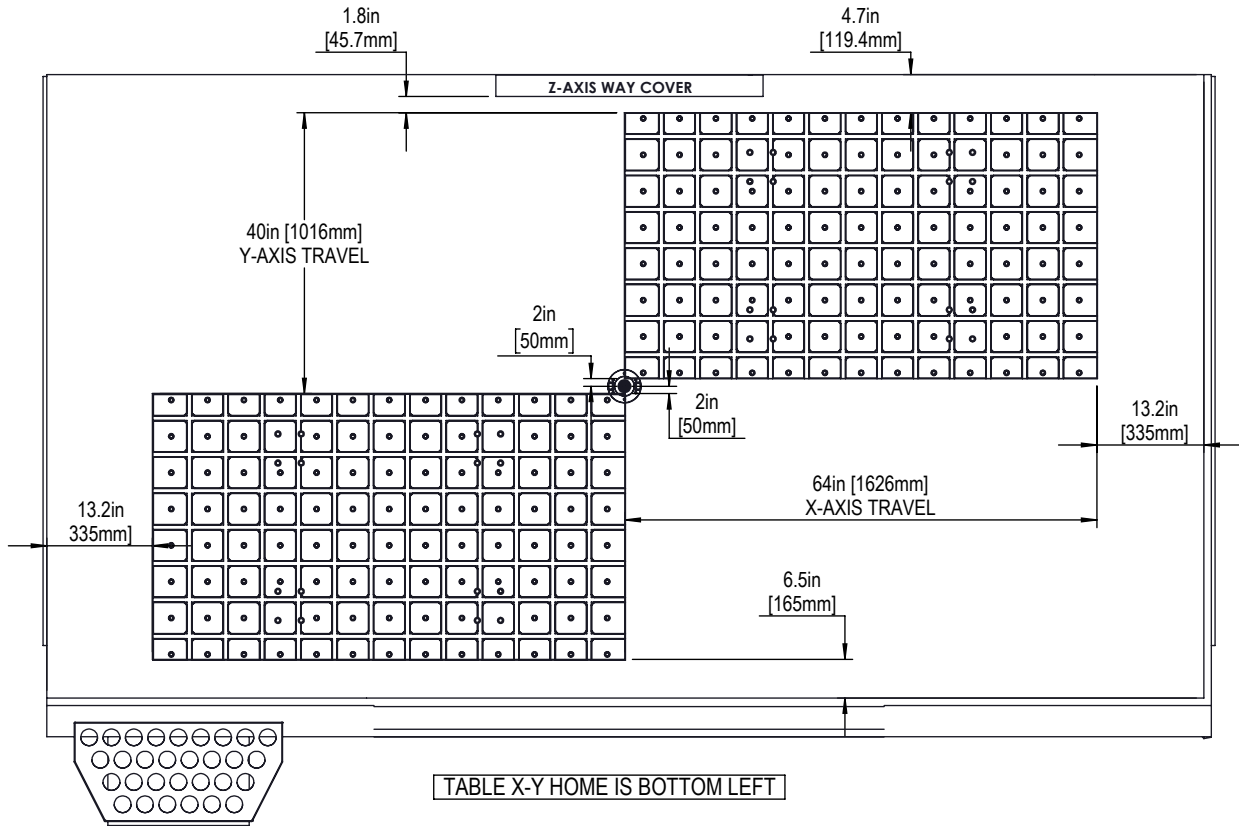

DRAWING NOT TO SCALE

Z AXIS TRAVEL

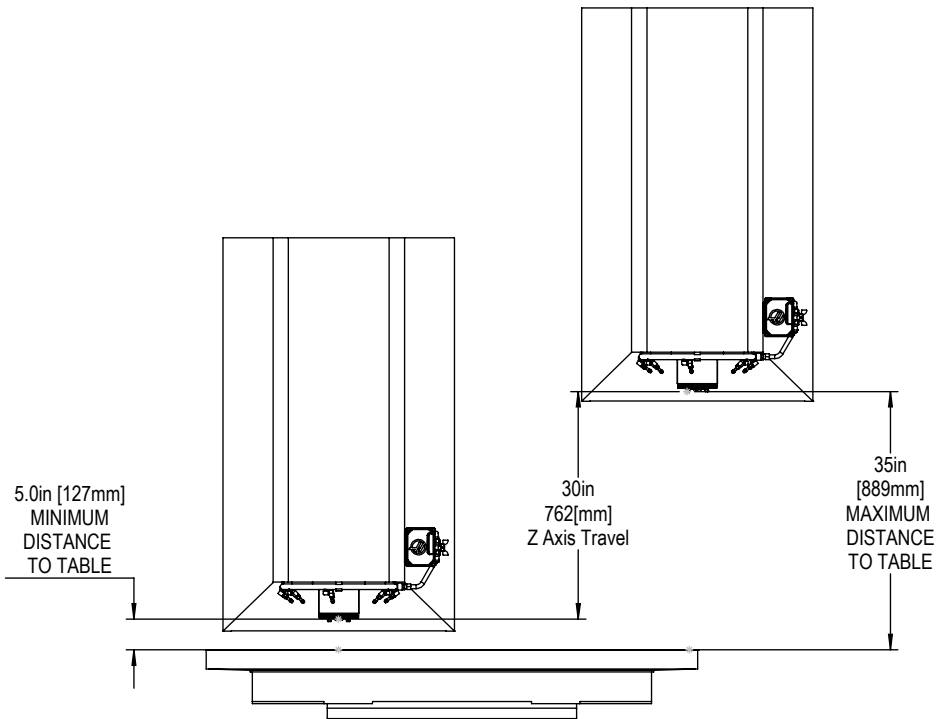

MACHINE TABLE FRONT VIEW

All dimensions based on stackup of sheetmetal, subject to variation of 1/2" (13 mm) Due to continual product improvements, dimensions are subject to change without notice



TABLE

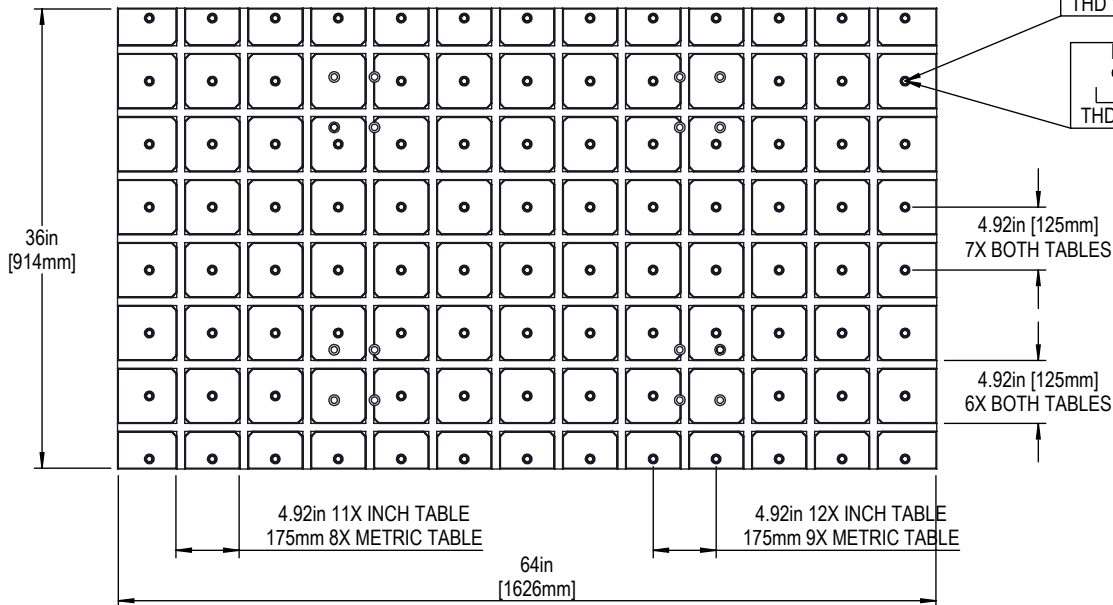

INCH TABLE 100X
 Φ 0.426in ∇ 1.75in
 \perp Φ 0.625in ∇ 0.625in
 THD 1/2-13 UNC-2B ∇ 1.375in

METRIC TABLE 80X
 Φ 10.2mm ∇ 44.4mm
 \perp Φ 16mm ∇ 15.9mm
 THD M12X1.75-6H ∇ 35mm

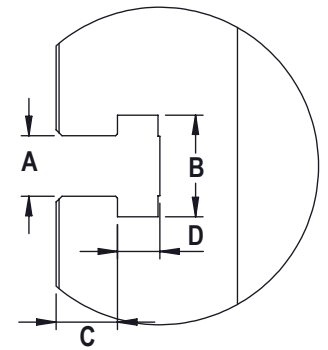

Slot Size	A	B	C	D
16mm	0.628in	1.06in	0.64in	0.42in
16mm	16mm	27mm	16mm	10.5mm

TOOL CHANGER

