

Shipping Dimensions

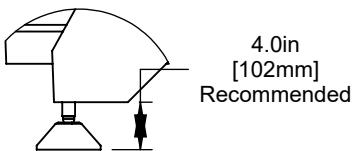

Max Travels		
X	32in	813mm
Y	25in	635mm
Z	28in	711mm
B	360°	

X&Y-Axis Clearance

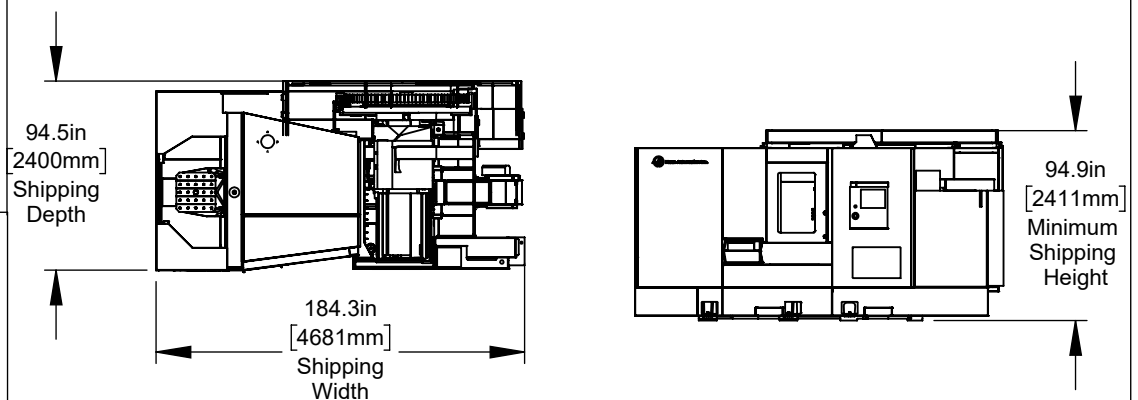
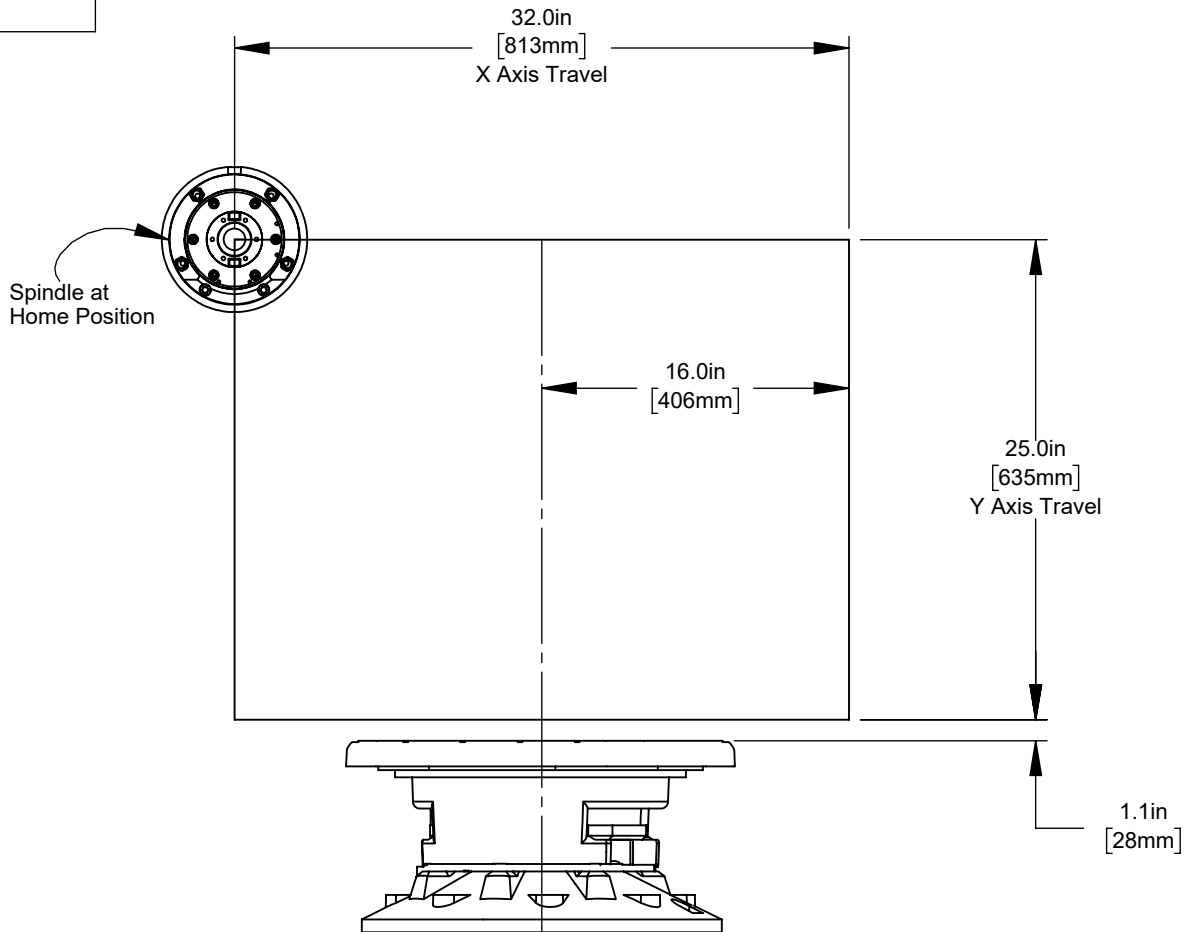

Z-Axis Clearance

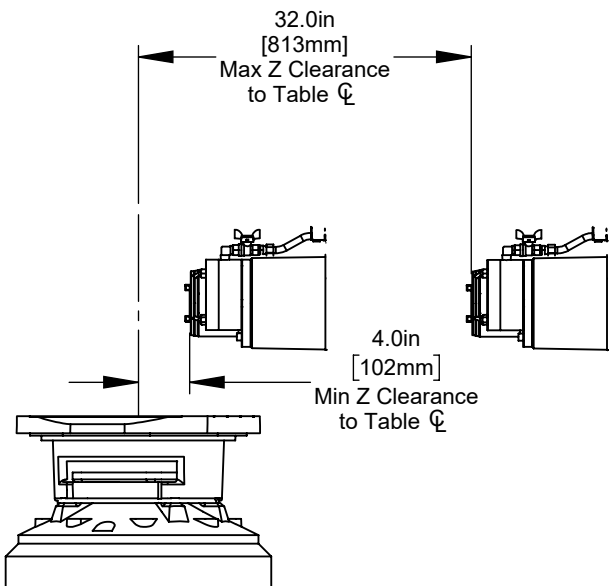

Work Envelope

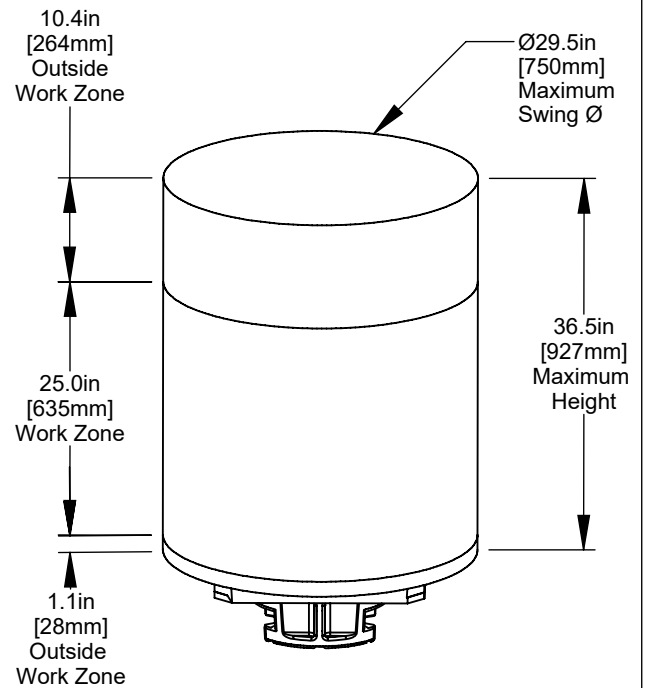

Table

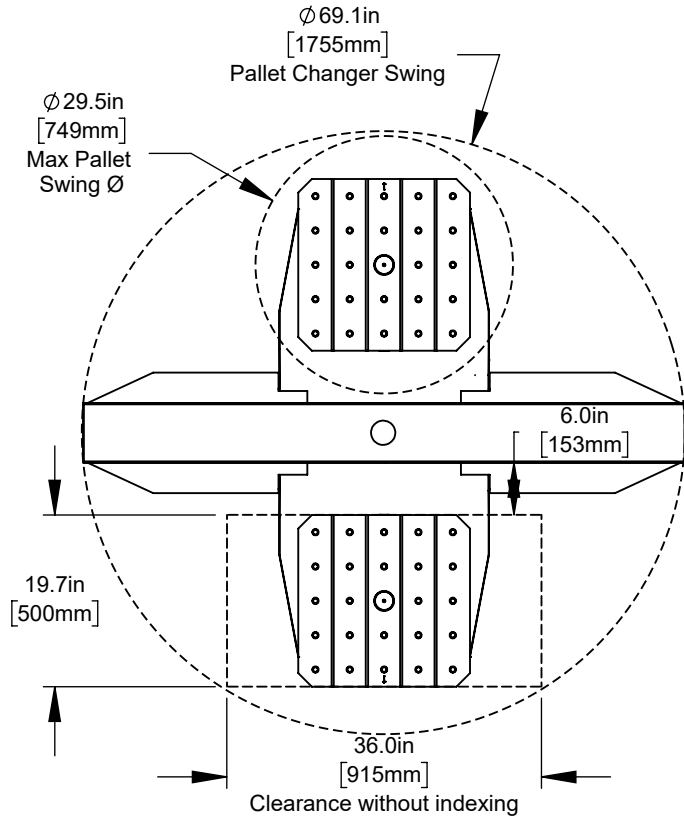

SAE / Inch Pallet

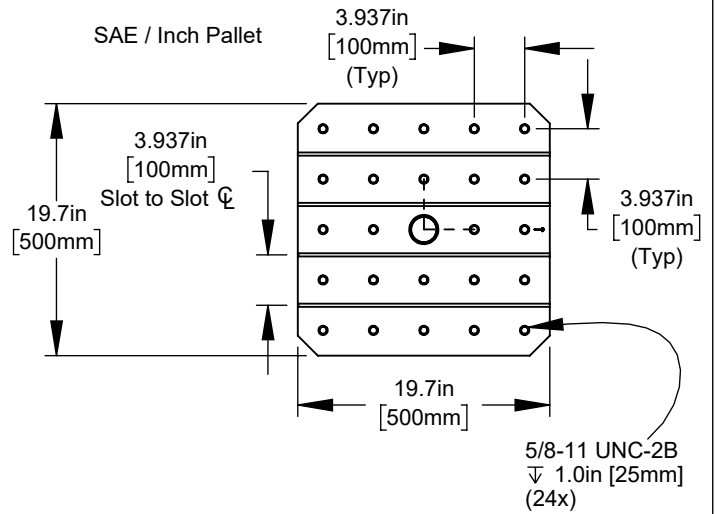

ISO / Metric Pallet

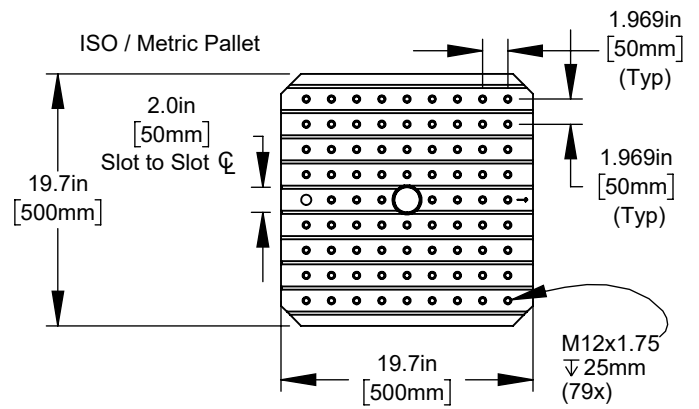

Tool Changer

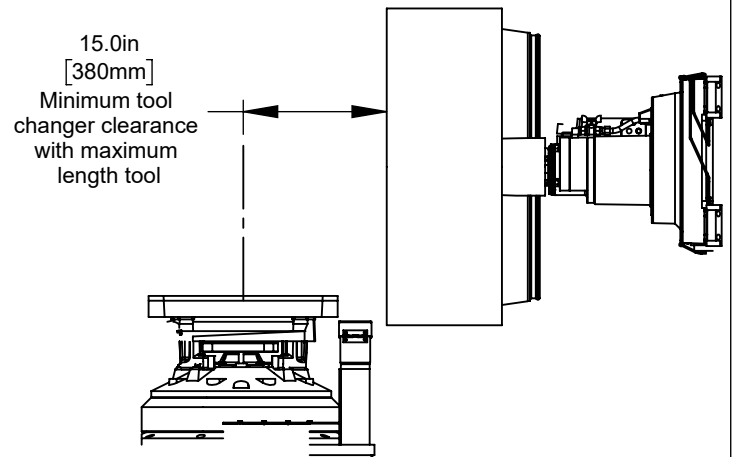
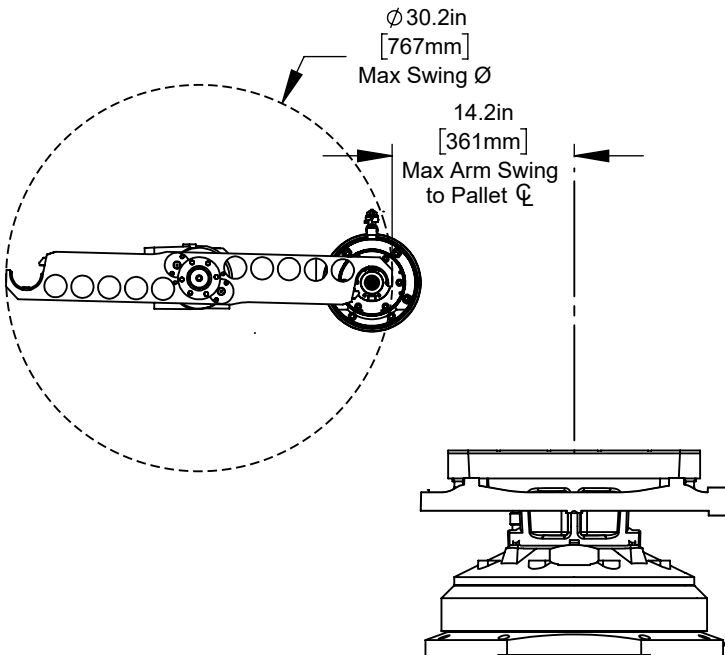

Air & Power

Top View

Right View

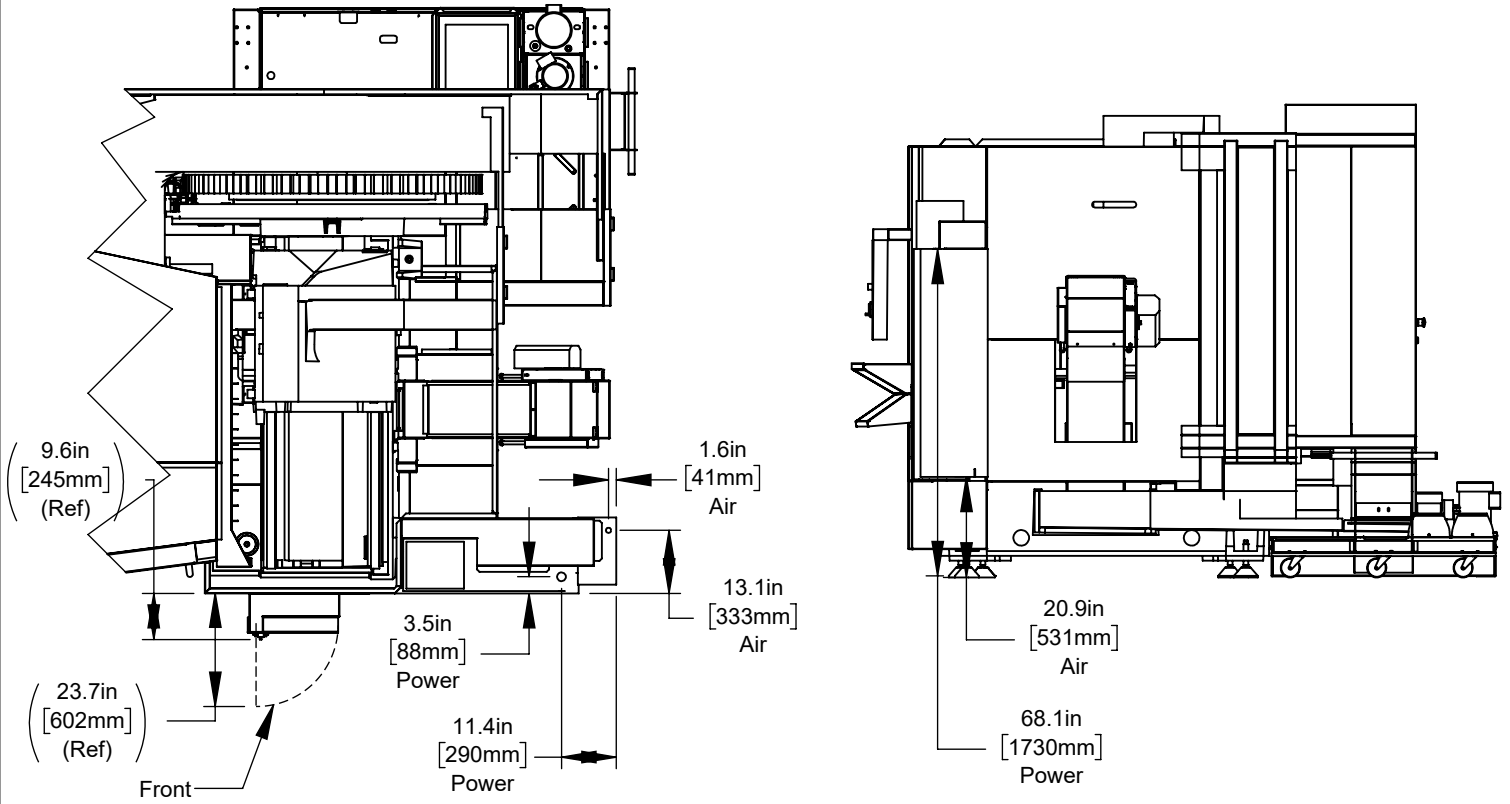

Anchor Pattern

Anchor Hole Detail
 Ø .625in [16mm]
 ▽ 3.5in [89mm]

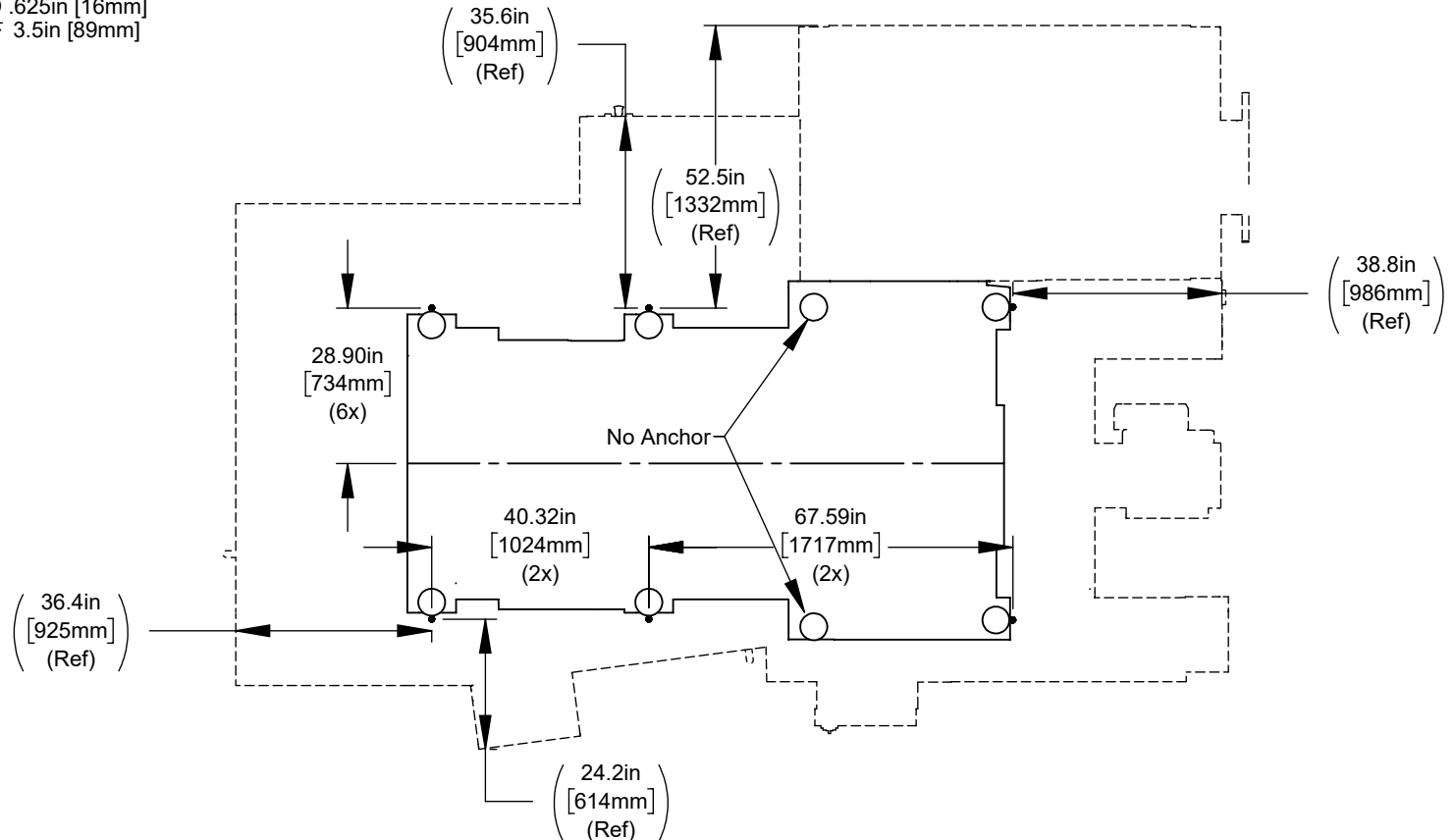

Height Breakdown

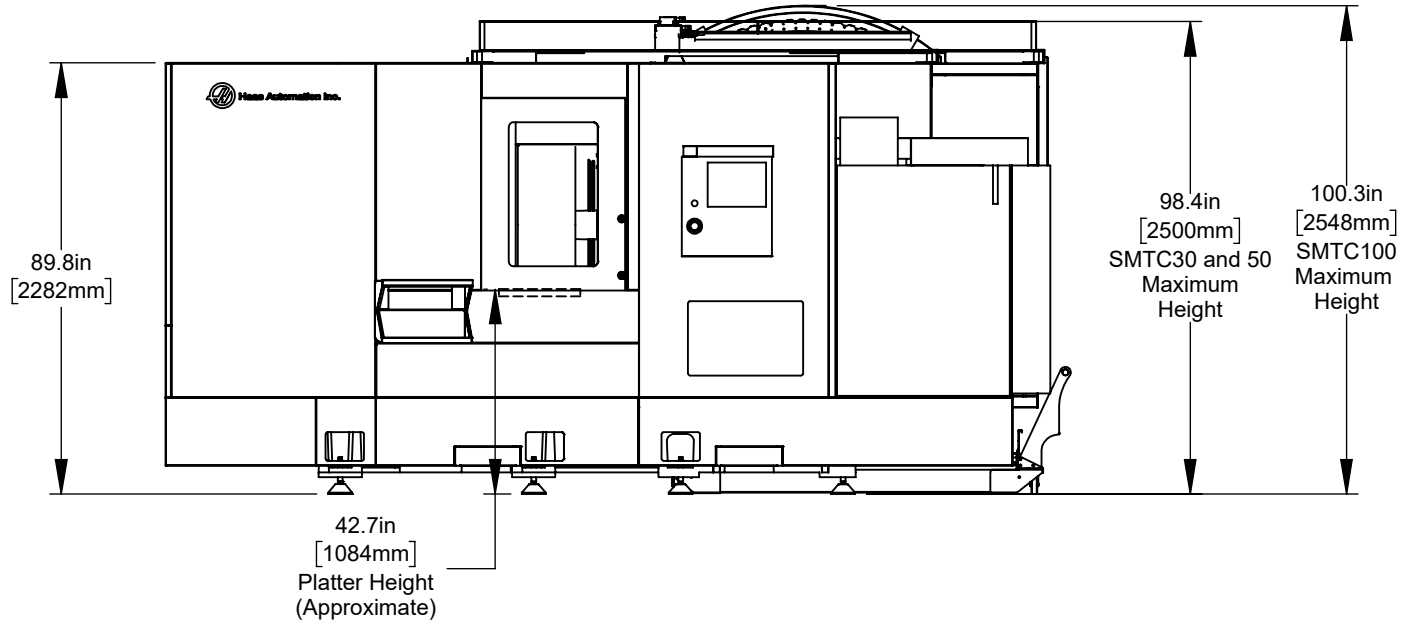

Width Breakdown

