

All dimensions based on stackup of sheetmetal, subject to variation of 1/2" (13 mm)

Air & Power

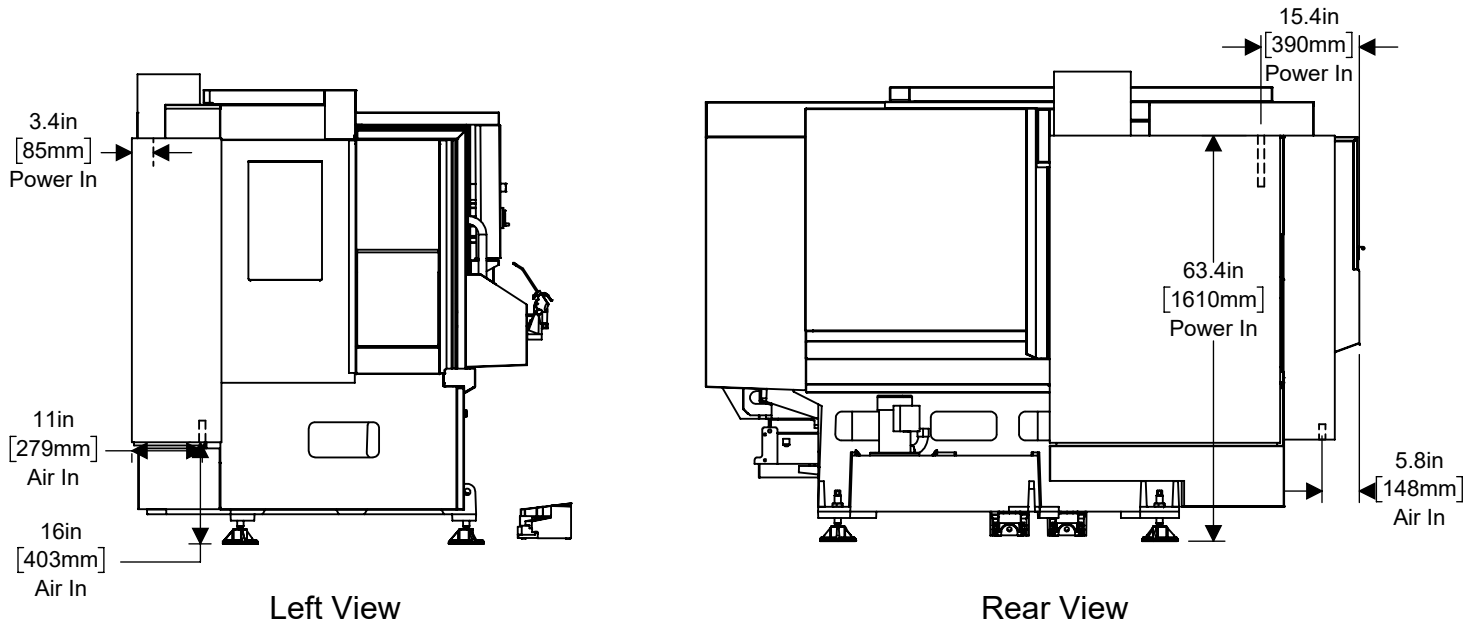

Anchor Pattern

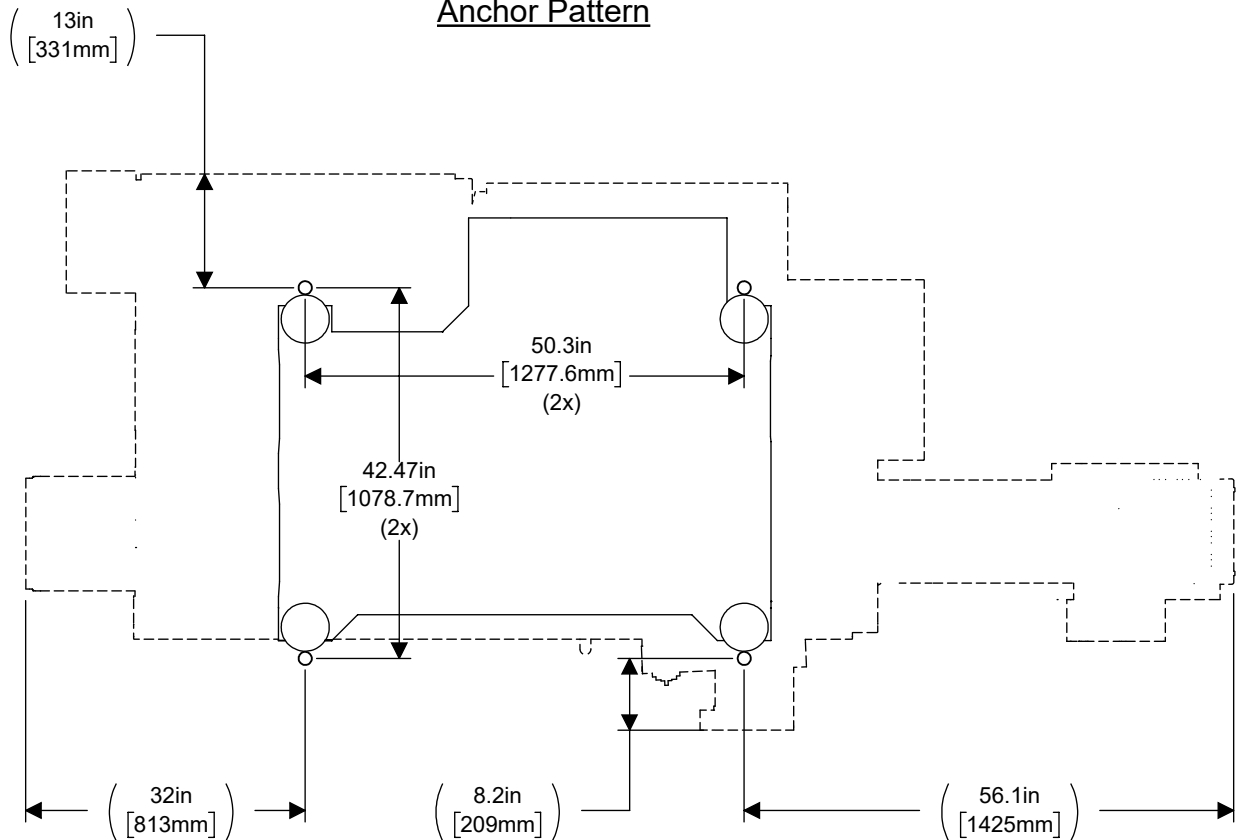

All dimensions based on stackup of sheetmetal, subject to variation of 1/2" (13 mm)

Height Breakdown

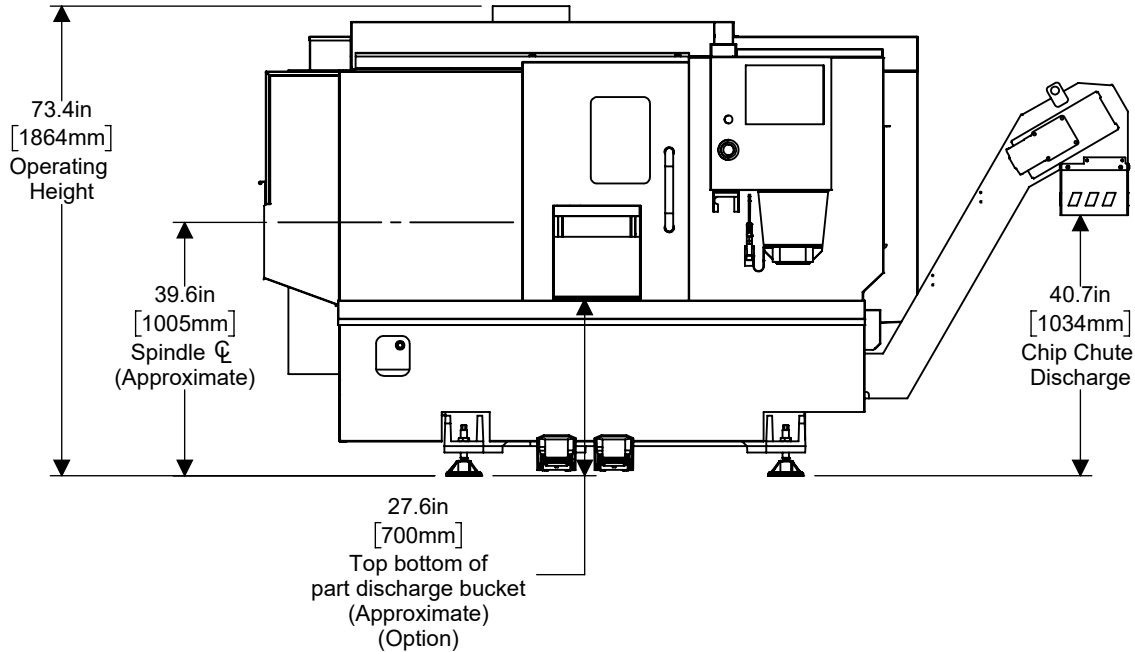

All dimensions based on stackup of sheetmetal, subject to variation of 1/2" (13 mm)

Width Breakdown

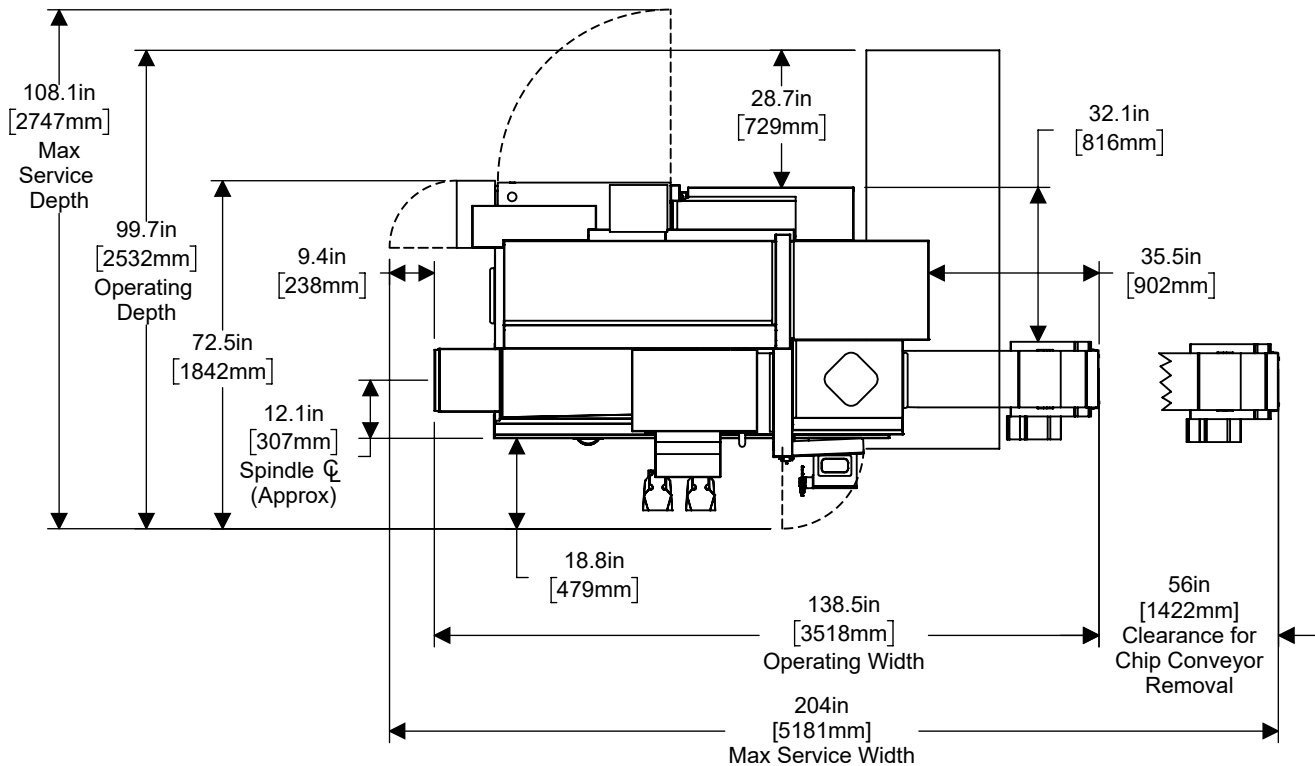

All dimensions based on stackup of sheetmetal, subject to variation of 1/2" (13 mm)

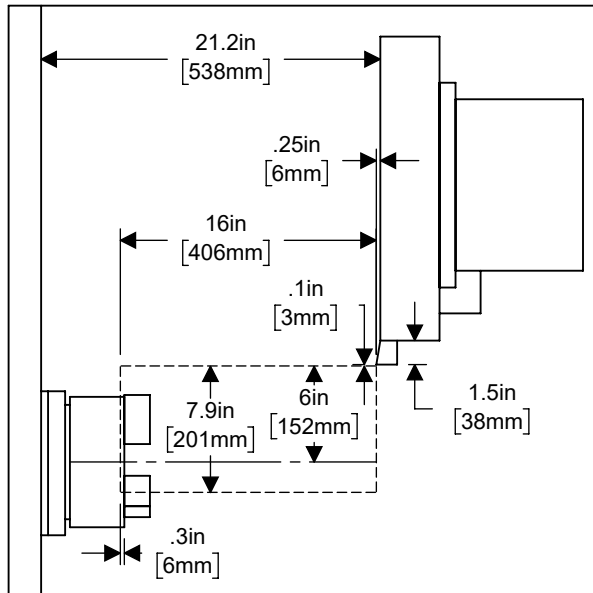

BOT OD*

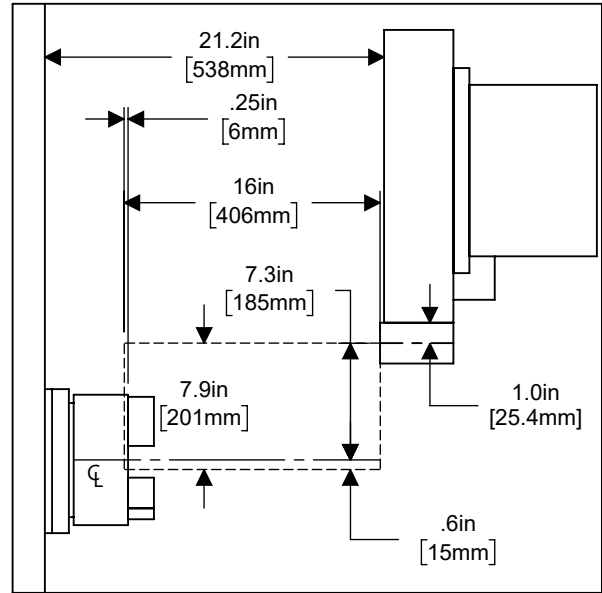

BOT ID / Drill / Bore **

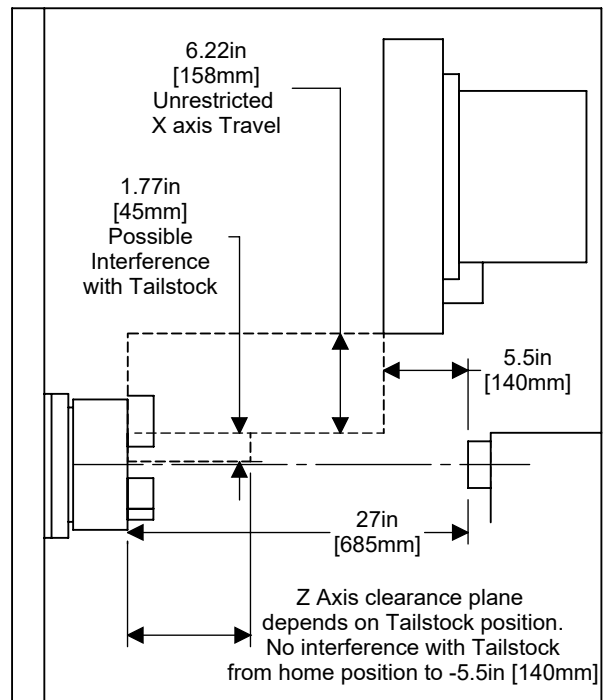
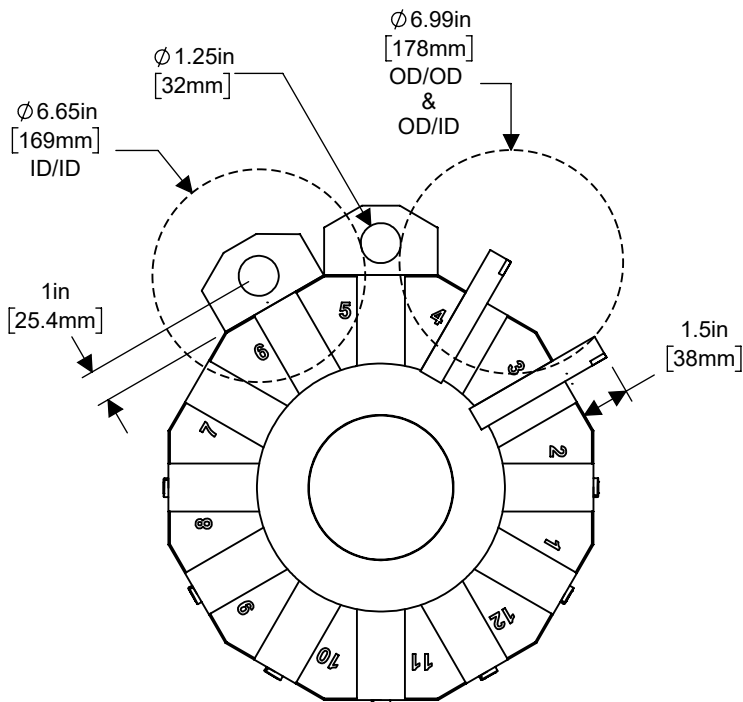

Tailstock

* Shift the work envelope in X by the tool protrusion length

** Shift the work envelope in Z by the tool protrusion length

Note - Sub Spindle not compatible with BOT Turret

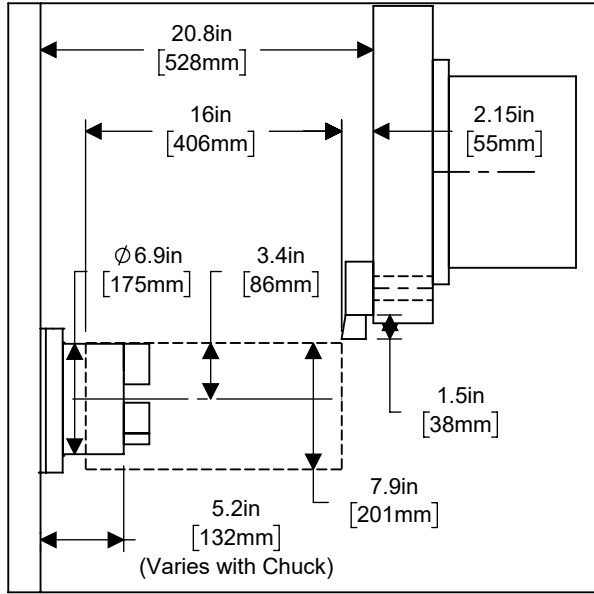

VDI OD
Short Holder
Even # Pockets (Inner Circle)

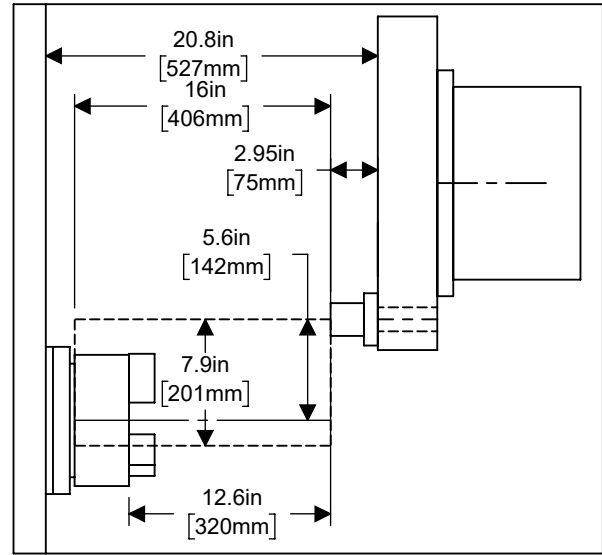

VDI ID
Odd # Pockets (Outer Circle)

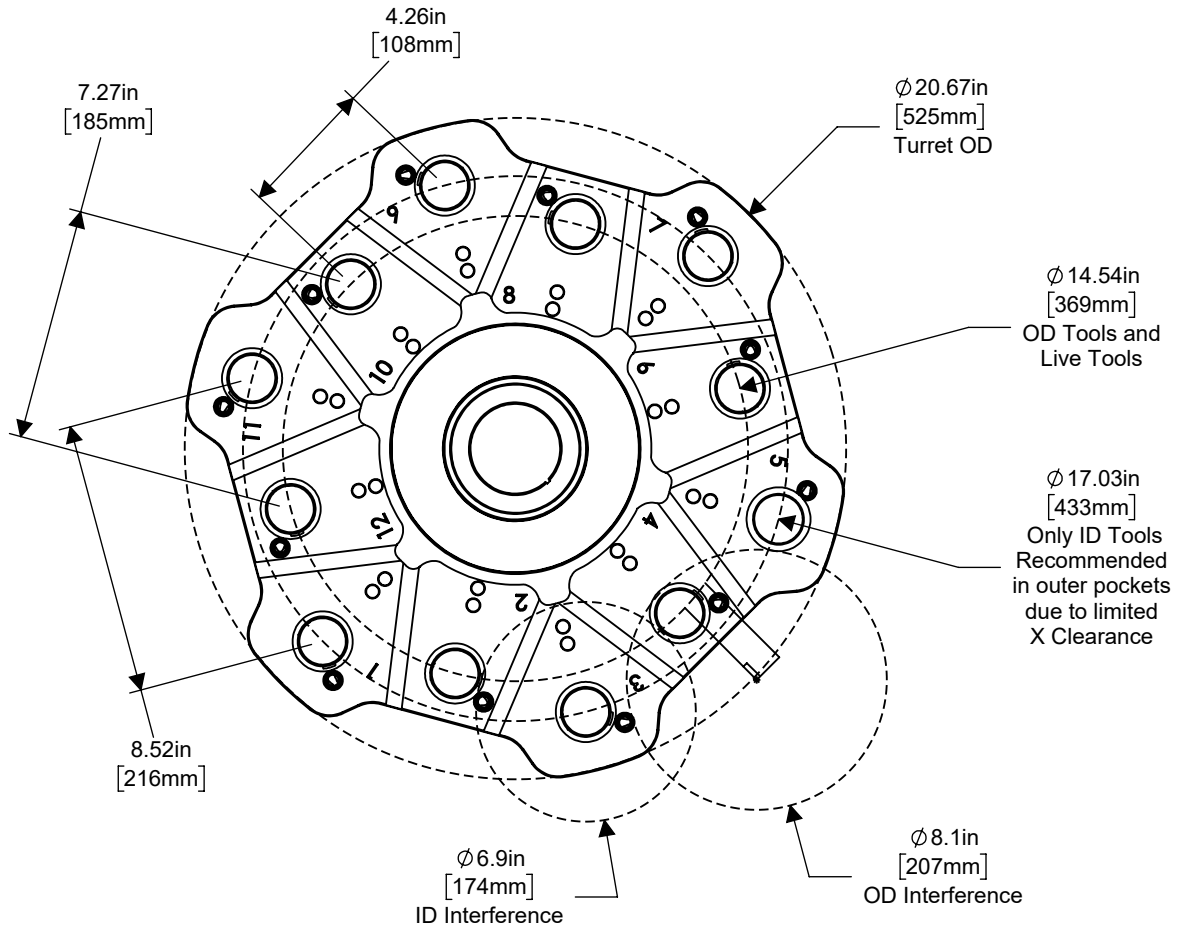

Note

1. Live tools (optional) **must** be installed on the inner pockets
2. If live tooling is not needed, the BOT turret offers a larger turning diameter
3. ID Tools such as drills or boring bars are recommended on the outer pockets, but may be placed in any pocket
4. Outside turning tool holders are only recommended on the **inner** ring of pockets (due to limited X Axis clearance if installed on the outer pockets)

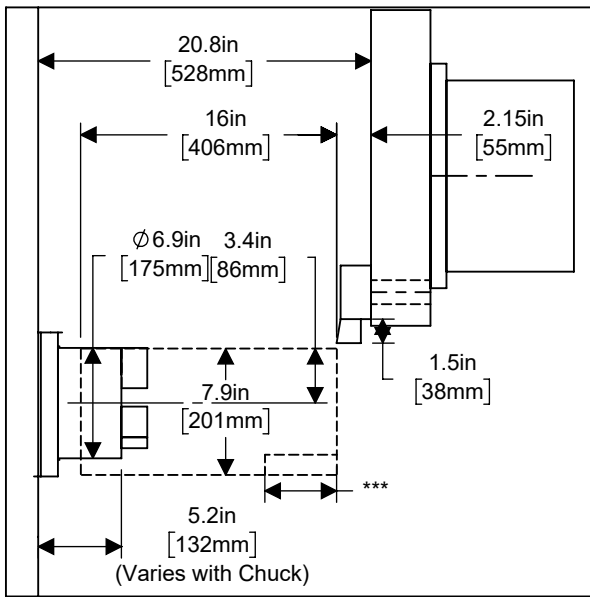

VDI OD, Short Holder, Inner Pocket

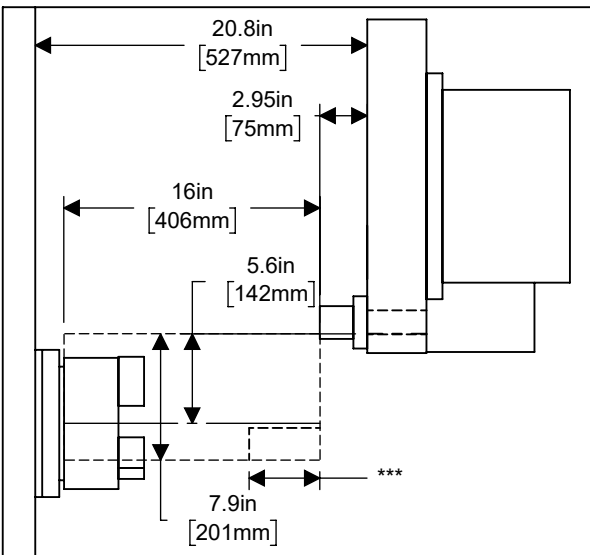

VDI ID Holder (Outer Pocket) */**

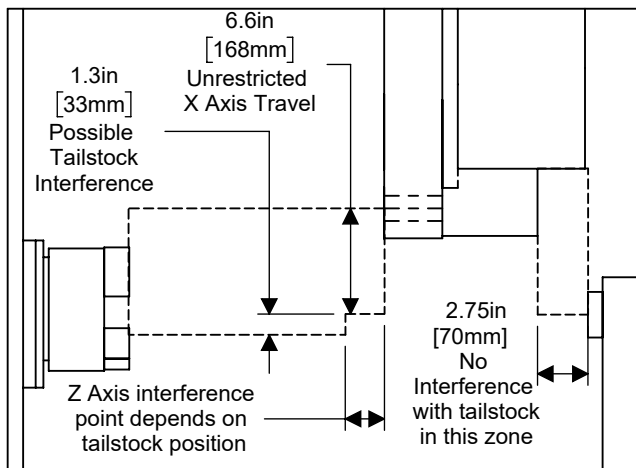

Turret / Tailstock interference zone common to all tools

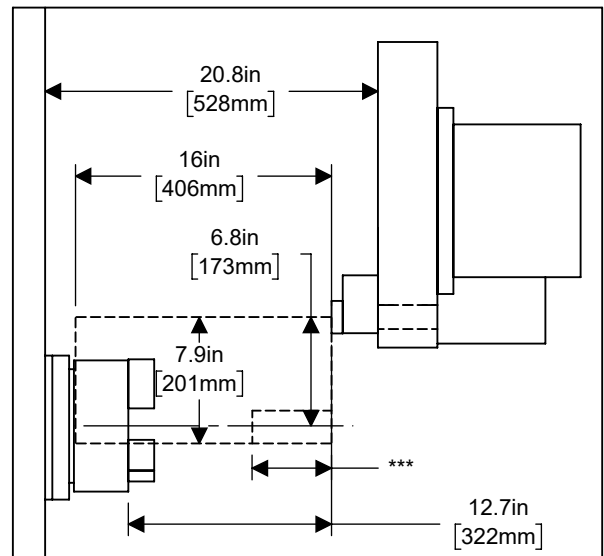
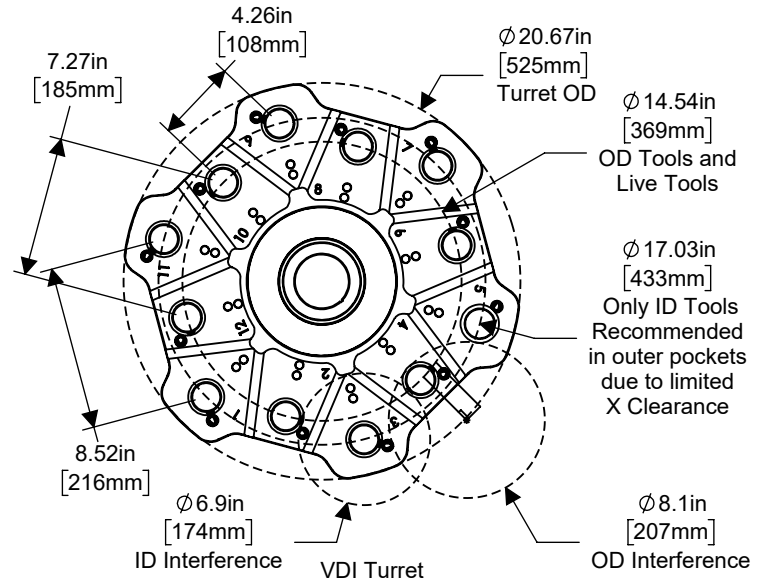

Axial Live Tool (Inner Pocket) */**

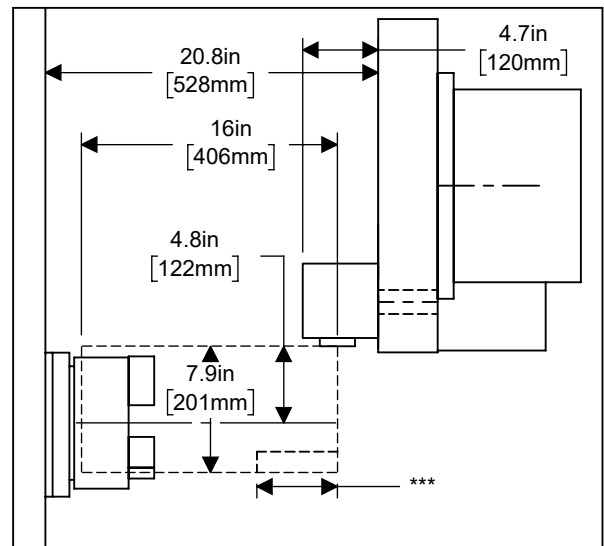

Radial Live Tool (Inner Pocket) */**

Note

1. Live tools (optional) **must** be installed on the inner pockets
2. If live tooling is not needed, the BOT turret offers a larger turning diameter
3. Outside turning tool holders are only recommended on the inner ring of pockets
4. ID Tools such as drills or boring bars are recommended on the outer pockets, but may be placed in any pocket

- * Shift the work envelope in X by the tool protrusion length
- ** Shift the work envelope in Z by the tool protrusion length
- ***Possible Tailstock Interference zone - see interference diagram

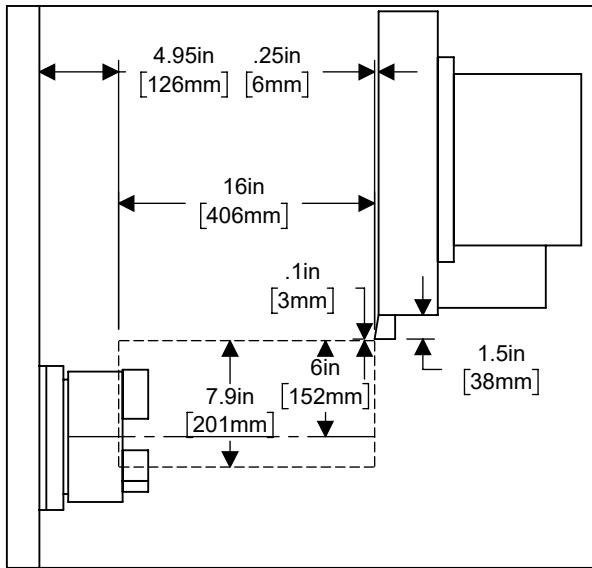

OD Stick Tool Slots on Face Hybrid Turret*

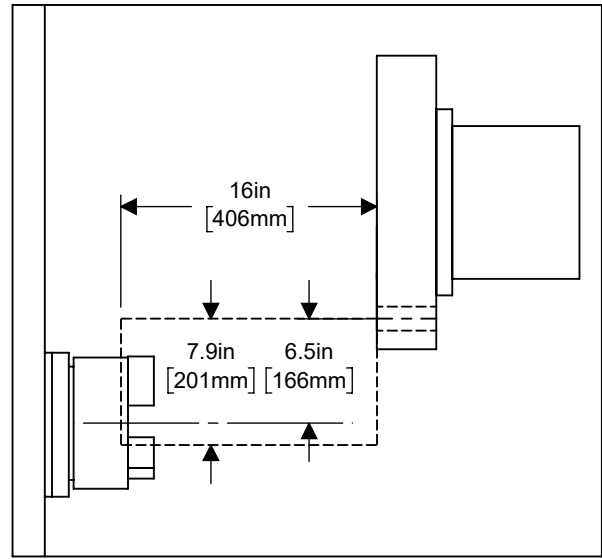

BOT ID */**

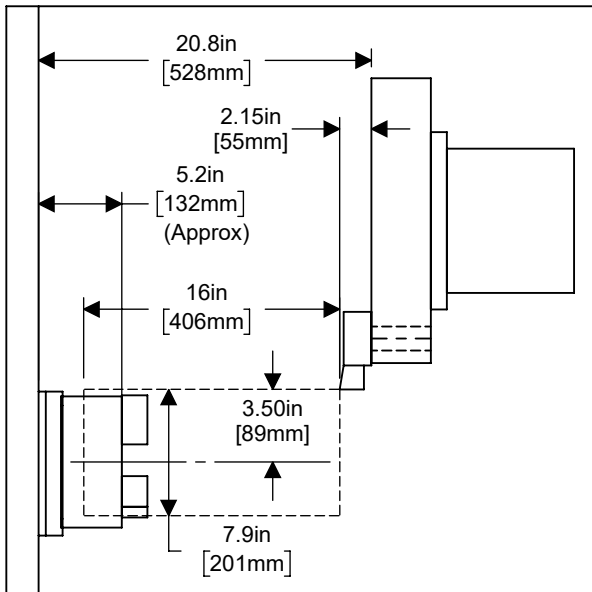

VDI OD Short

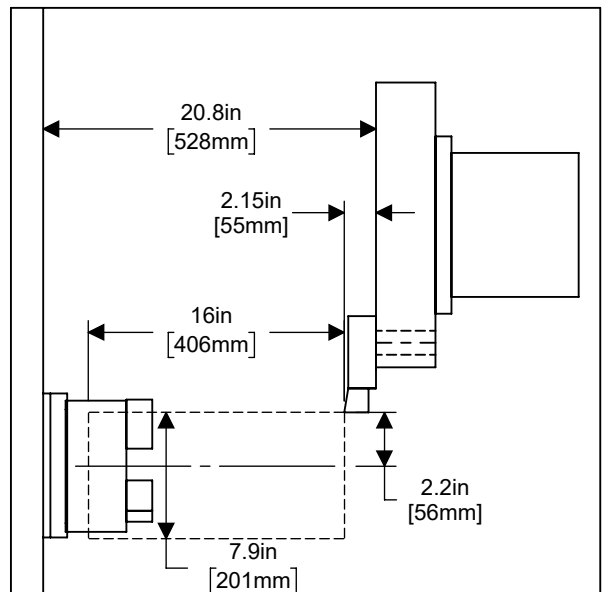

VDI OD Long

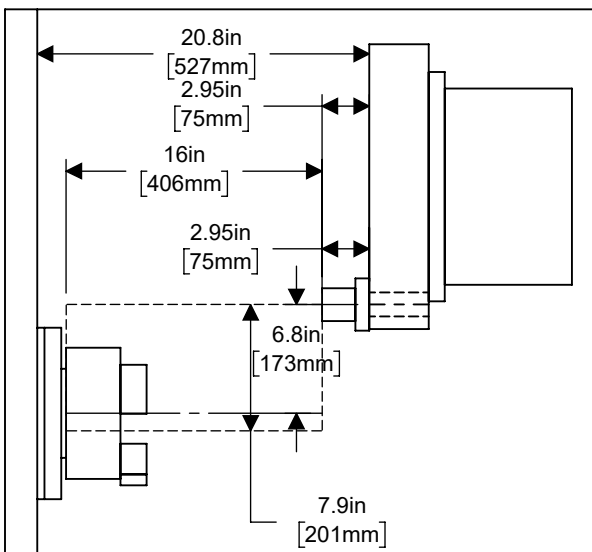

VDI ID */**

Note - Hybrid Turret travel diagrams do not show interference zone created by the combination of machine options. If Sub Spindle or Tailstock with Live Tool options are both selected, see next page for turret interference zone

* Shift the work envelope in X by the tool protrusion length

** Shift the work envelope in Z by the tool protrusion length

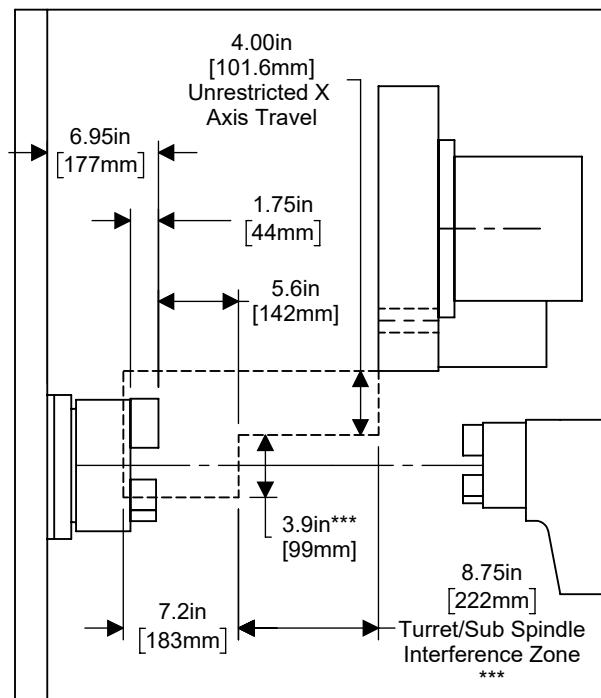
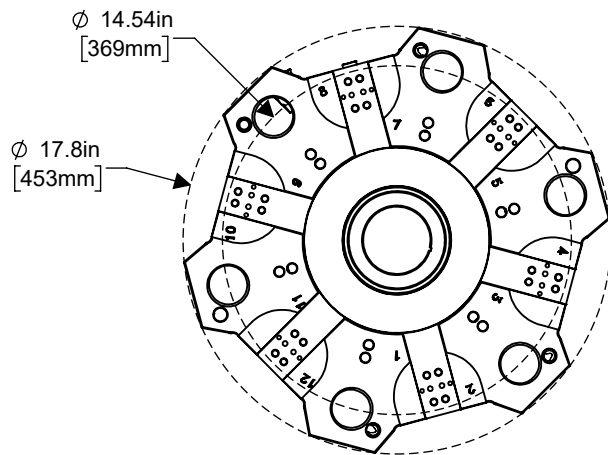
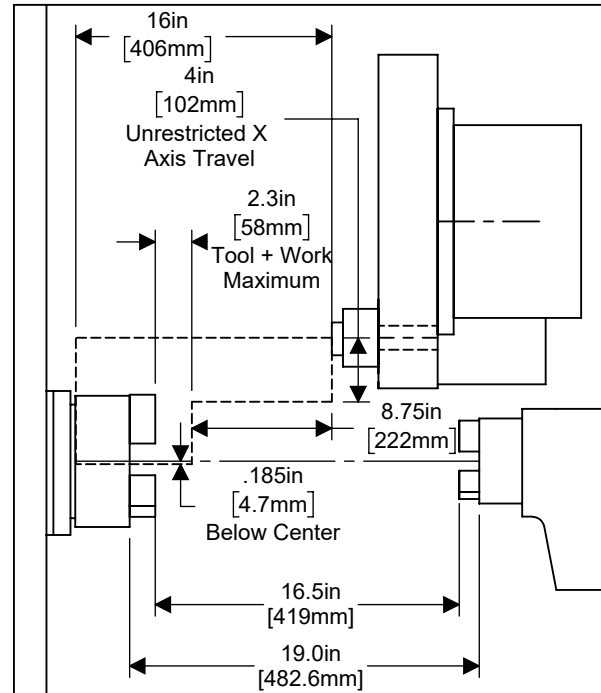
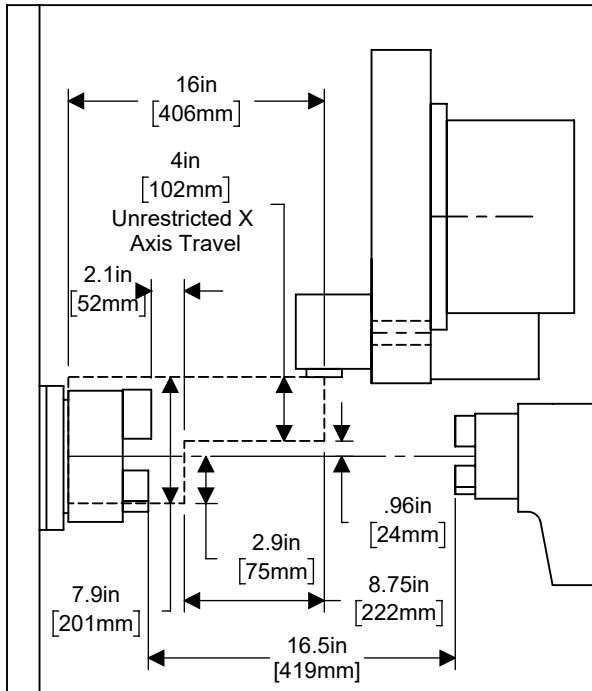

Sub Spindle / Live Tool interference zone

***To enter the interference zone, the Z axis must be Z-8.75" [222mm] from home position before the X axis can enter the lower 3.9in [99mm] of travel. This results in approximately 5.6in [142mm] clearance between the standard jaw face and the turret face.

The interference zone only applies to machines with both the Sub Spindle and Live Tool options

* Shift the work envelope in X by the tool protrusion length

** Shift the work envelope in Z by the tool protrusion length

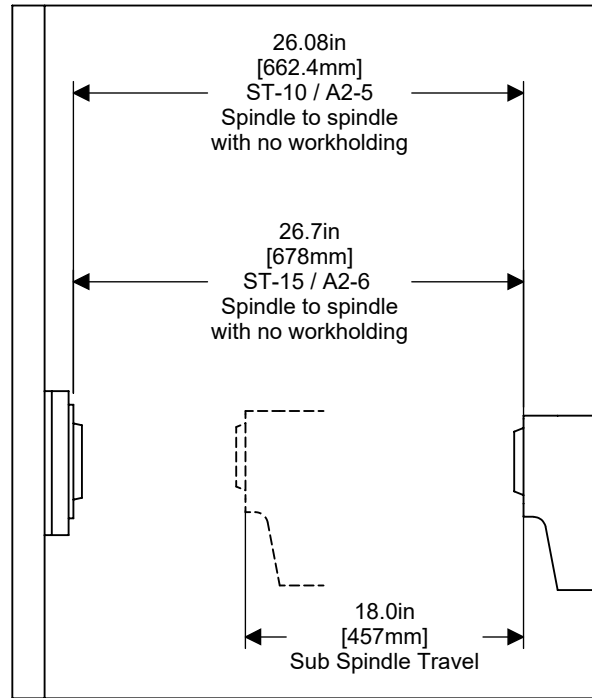

Spindle to Spindle distance

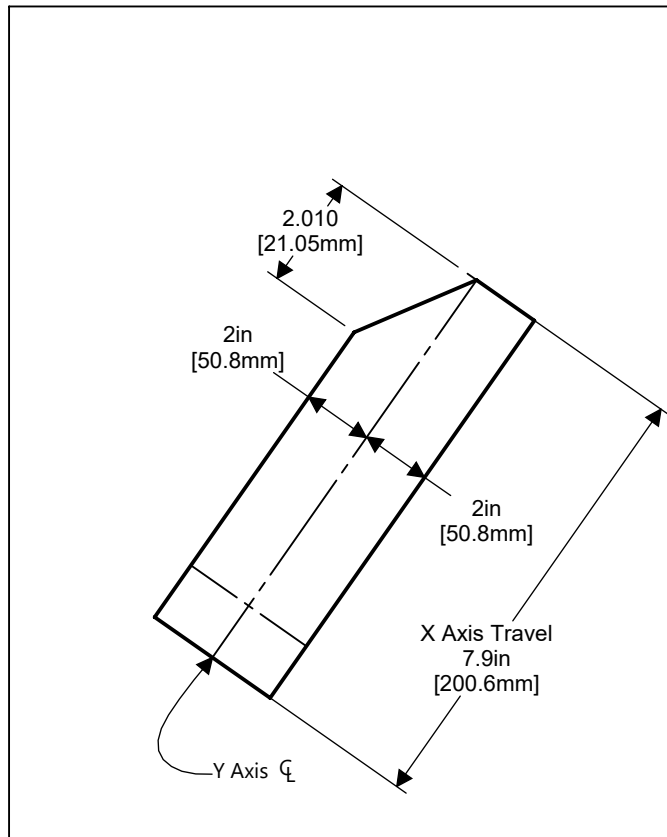

Y Axis Envelope
Machine Travel

* Shift the work envelope in X by the tool protrusion length

** Shift the work envelope in Z by the tool protrusion length

Barfeeder Layout

Footprint with Bar Feeder in Rear / Service position

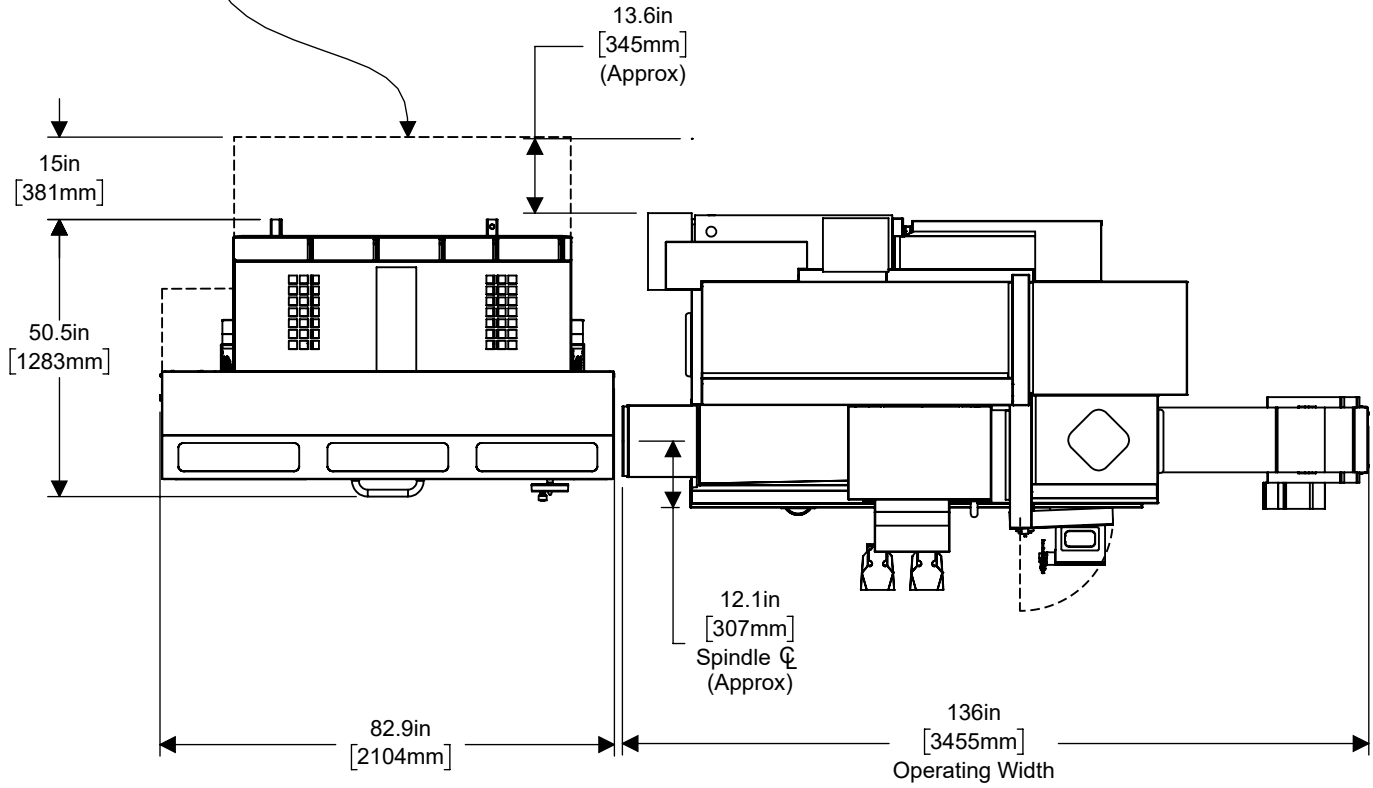

All dimensions based on stackup of sheetmetal, subject to variation of 1/2" (13 mm)

Specifications subject to change at any time without notice

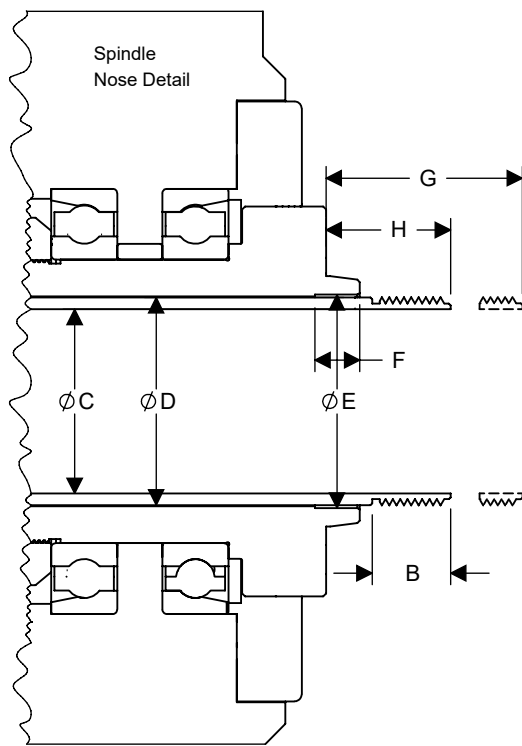
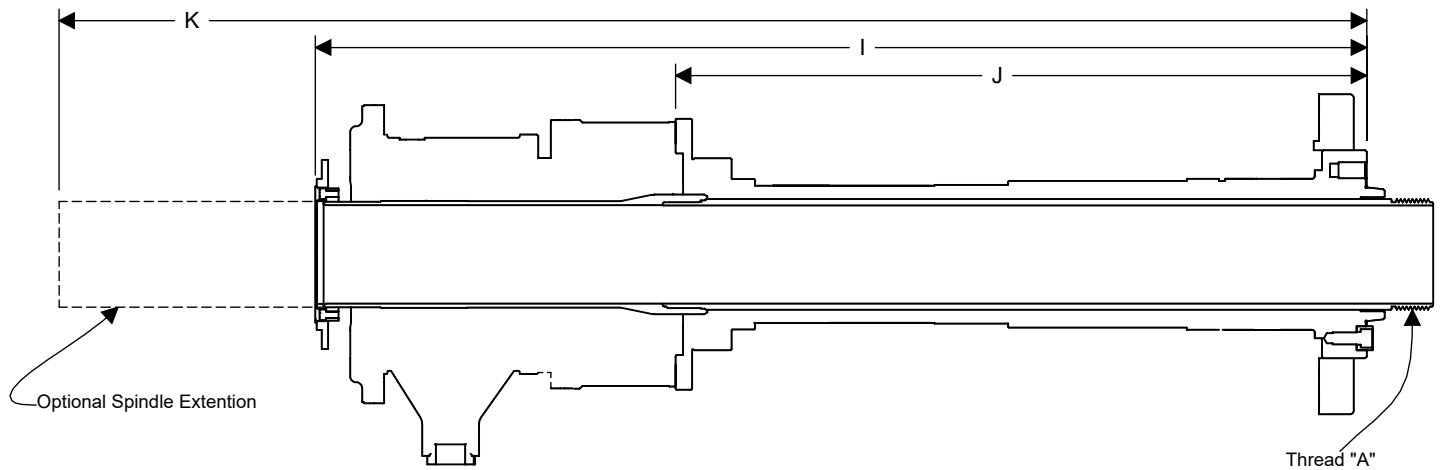

BHC and Spindle Nose dimensions per American Standard Bulletin ASA B5.9 1960

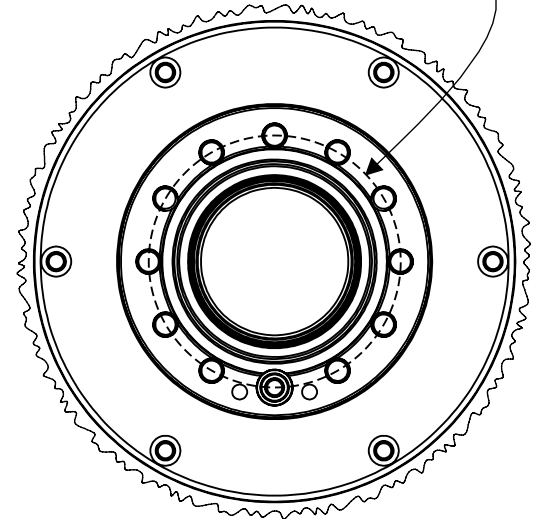

The following dimensions should be used as a reference only. Haas uses many different vendors for our drawtube assemblies. If any custom workholding is required Haas recommends you retrieve the exact dimensions from your delivered machine.

ST-10/15/Y/Reboot Spindle Schematic for all vintages					
DESCRIPTION	DIMENSION	ST-10/Y		ST-15/Y	
		SAE	METRIC	SAE	METRIC
MAIN OR SUB SPINDLE & TYPE		Main / A2-5		Main / A2-6	
DIAMETER OF THREAD	A	2.165"	55 MM	2.95"	75 MM
THREAD PITCH	A	0.0787"	2.0 MM	0.0787"	2.0 MM
INTERNAL OR EXTERNAL	A	External		External	
LENGTH OF THREAD	B	0.70"	17.78 MM	1.36"	34.54 MM
DRAWTUBE INNER DIAMETER	C	1.81"	45.98 MM	2.56"	65 MM
DRAWTUBE OUTER DIAMETER	D	2.25"	57.15 MM	3.03"	76.96 MM
COUNTERBORE INNER DIAMETER	E	2.50"	63.5 MM	3.52"	89.4 MM
COUNTERBORE DEPTH	F	0.620"	15.75 MM	0.75"	19.05 MM
DRAWTUBE EXTENDED DISTANCE	G	1.68"	42.7 MM	1.98"	50.3 MM
DRAWTUBE RETRACTED DISTANCE	H	1.09"	27.7 MM	1.11"	28.19 MM
SPINDLE FACE TO BACK OF UNION	I	30.78"	781.8 MM	33.53"	851.67 MM
SPINDLE FACE TO UNION ADAPTOR	J	22.75"	578 MM	22.53"	572.3 MM
TO BACK OF EXTENTION (OPTION)	K	48.0"	1219MM	48.0"	1219MM

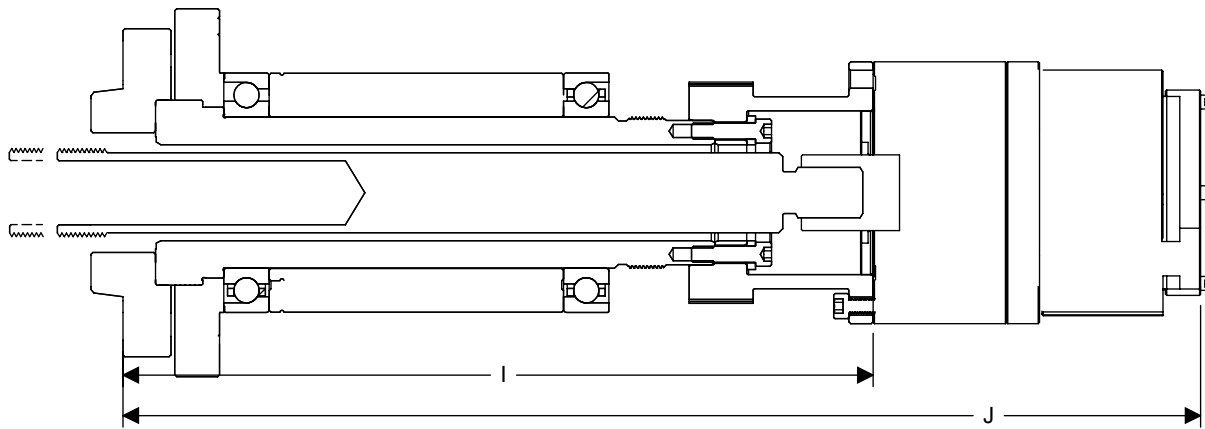

BHC and Spindle Nose dimensions per American Standard Bulletin ASA B5.9 1960

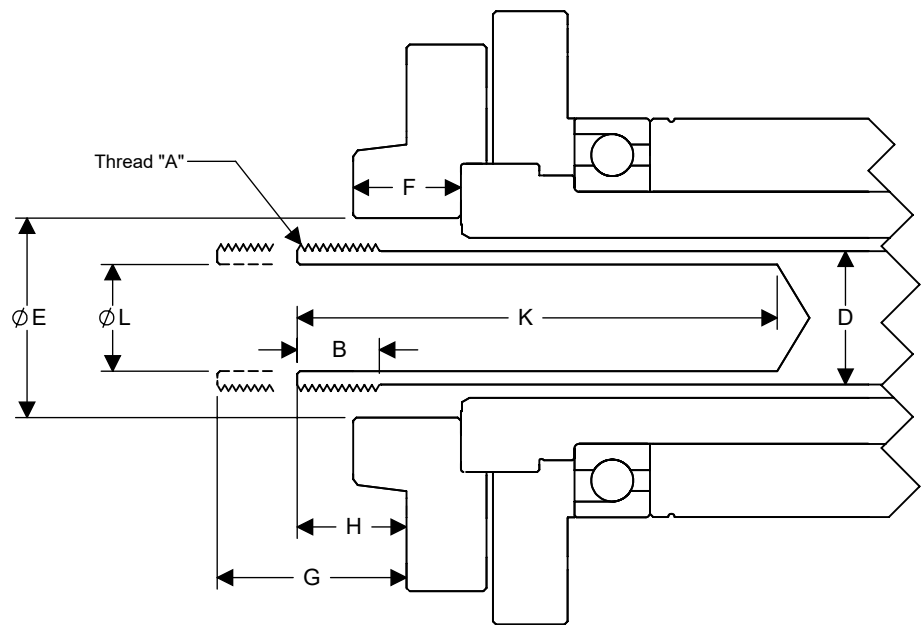
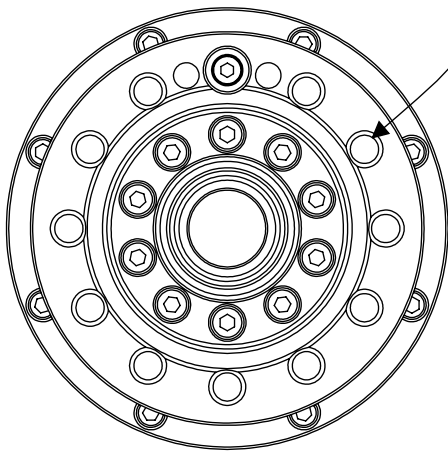

The following dimensions should be used as a reference only. Haas uses many different vendors for our drawtube assemblies. If any custom workholding is required Haas recommends you retrieve the exact dimensions from your delivered machine.

SUB-SPDL-A2-5 for ST-10 to ST-25			
DESCRIPTION	DIMENSION	SAE	METRIC
MAIN OR SUB SPINDLE & TYPE		Sub-Spindle / A2-5	
DIAMETER OF THREAD	A	1.378"	35 MM* or 40 MM
THREAD PITCH	A	0.059"	1.5 MM
INTERNAL OR EXTERNAL	A	External	
LENGTH OF THREAD	B	0.50"	12.7 MM
DRAWTUBE INNER DIAMETER	C	N/A - SOLID DRAWBAR	
DRAWTUBE OUTER DIAMETER	D	1.25"	31.75MM
COUNTERBORE INNER DIAMETER	E	1.870"	47.5 MM
COUNTERBORE DEPTH	F	1.01"	25.65MM
EXTENDED DISTANCE TO NOSE	G	1.465"	37.2 MM
RETRACTED DISTANCE TO NOSE	H	0.874"	22.2 MM
FROM SPINDLE FACE TO BACK OF UNION	I	11.72	297.7MM
FROM SPINDLE FACE TO UNION ADAPTOR	J	16.84	427.7MM
EJECTOR POCKET DEPTH	K	4.5"	114.3MM
EJECTOR POCKET DIAMETER	L	1.0"	25.4MM

*M35 applies to Sub-Spindles made after July 2019 - M40 applies to older vintages