

INSTALLATION DIMENSIONS

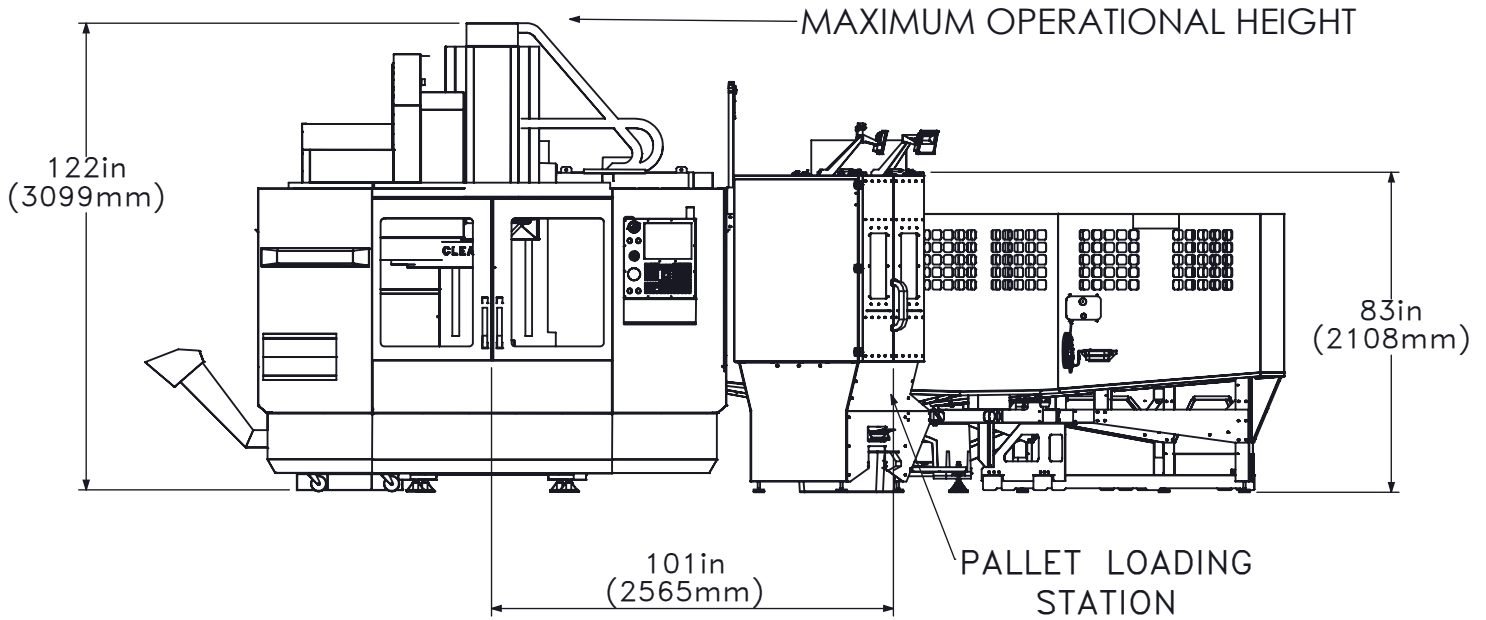

Maintain 3 feet (915 mm) clearance to the nearest obstruction around all sides of machine perimeter for maintenance access

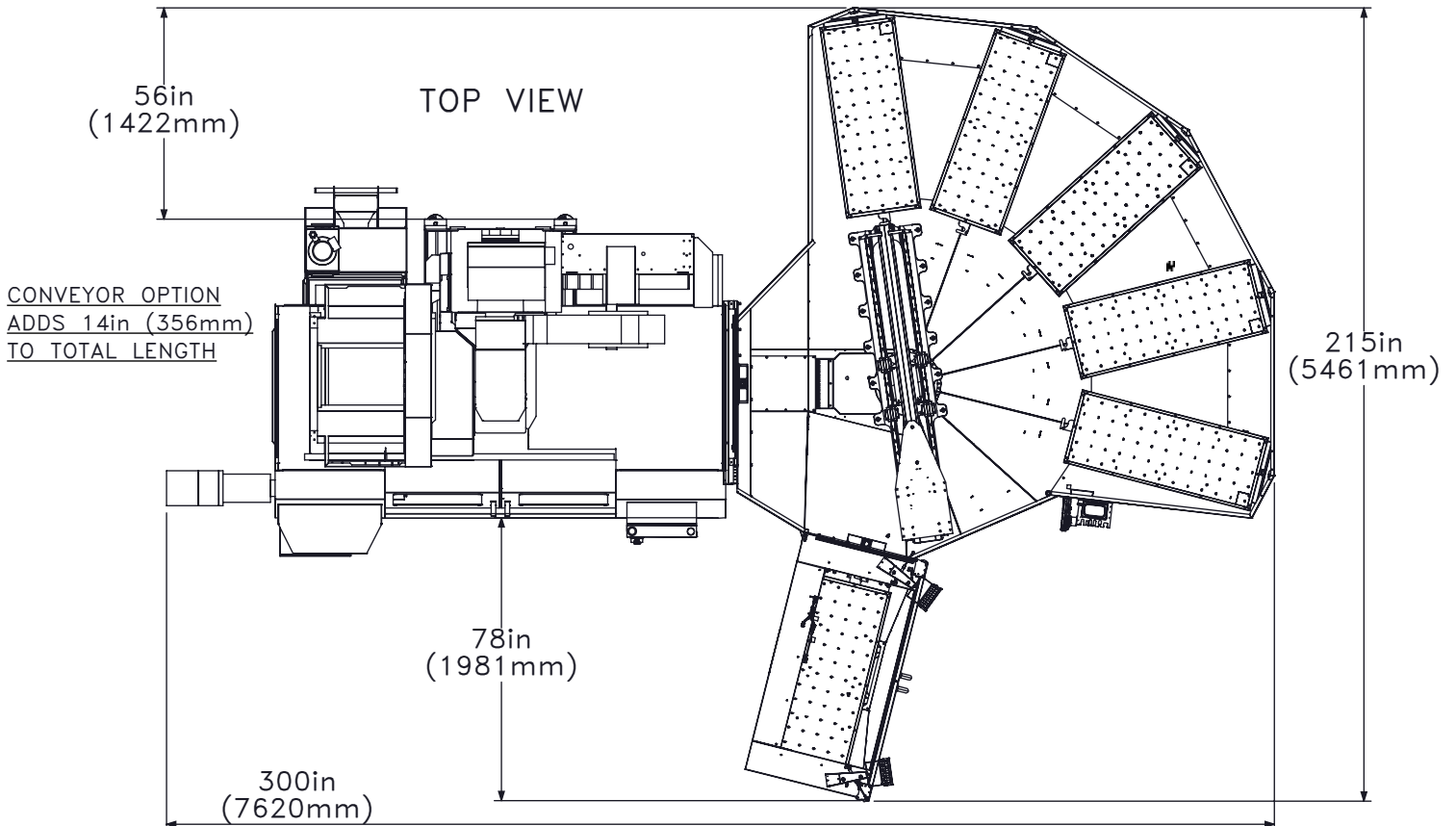

PALLET LOADING VIEW

LOAD STATION
DOOR OPENING
63in (1600mm)

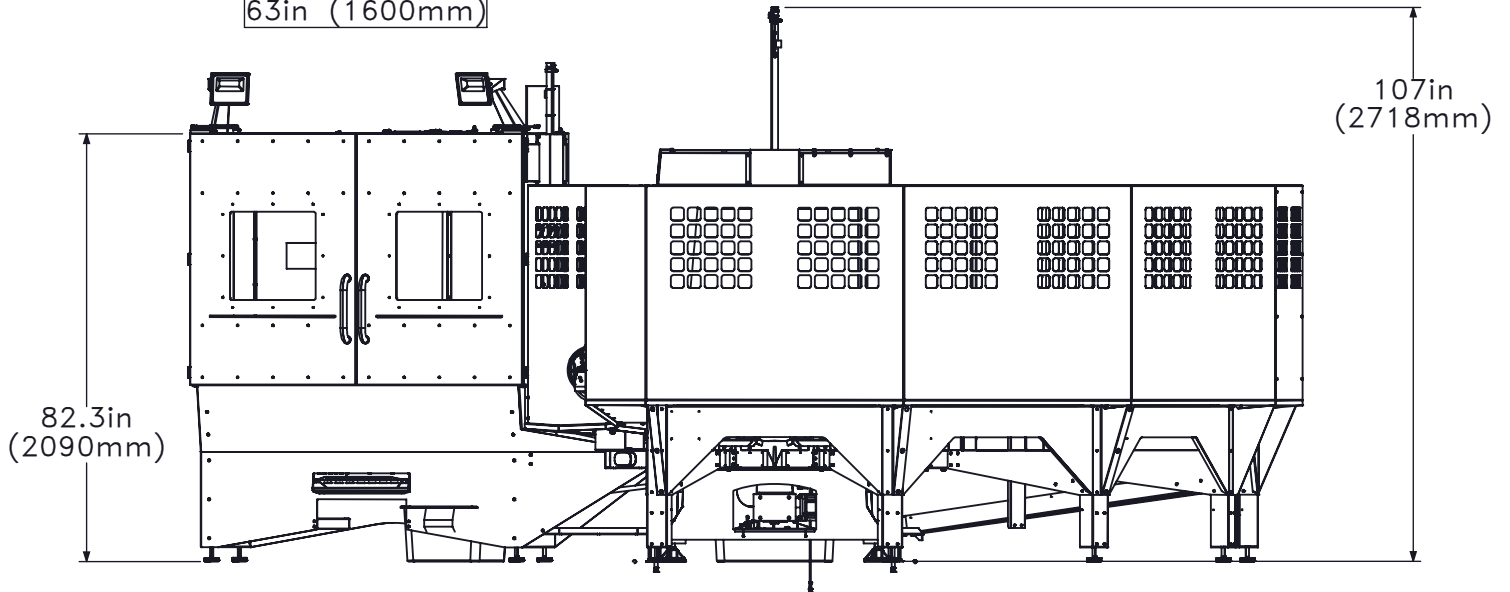

Maintain 3 feet (915 mm) clearance to the nearest obstruction around all sides of machine perimeter for maintenance access

TOP VIEW

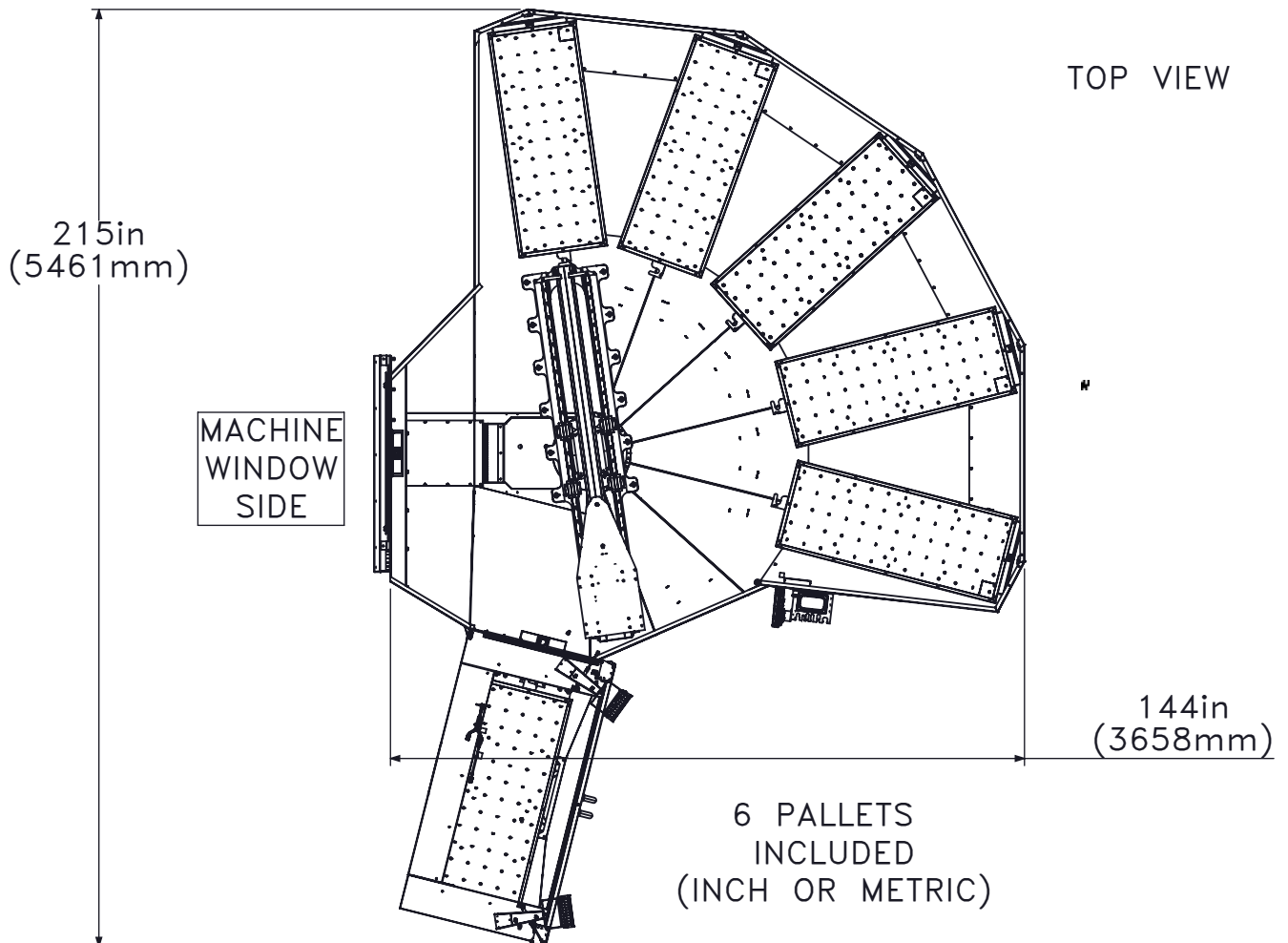

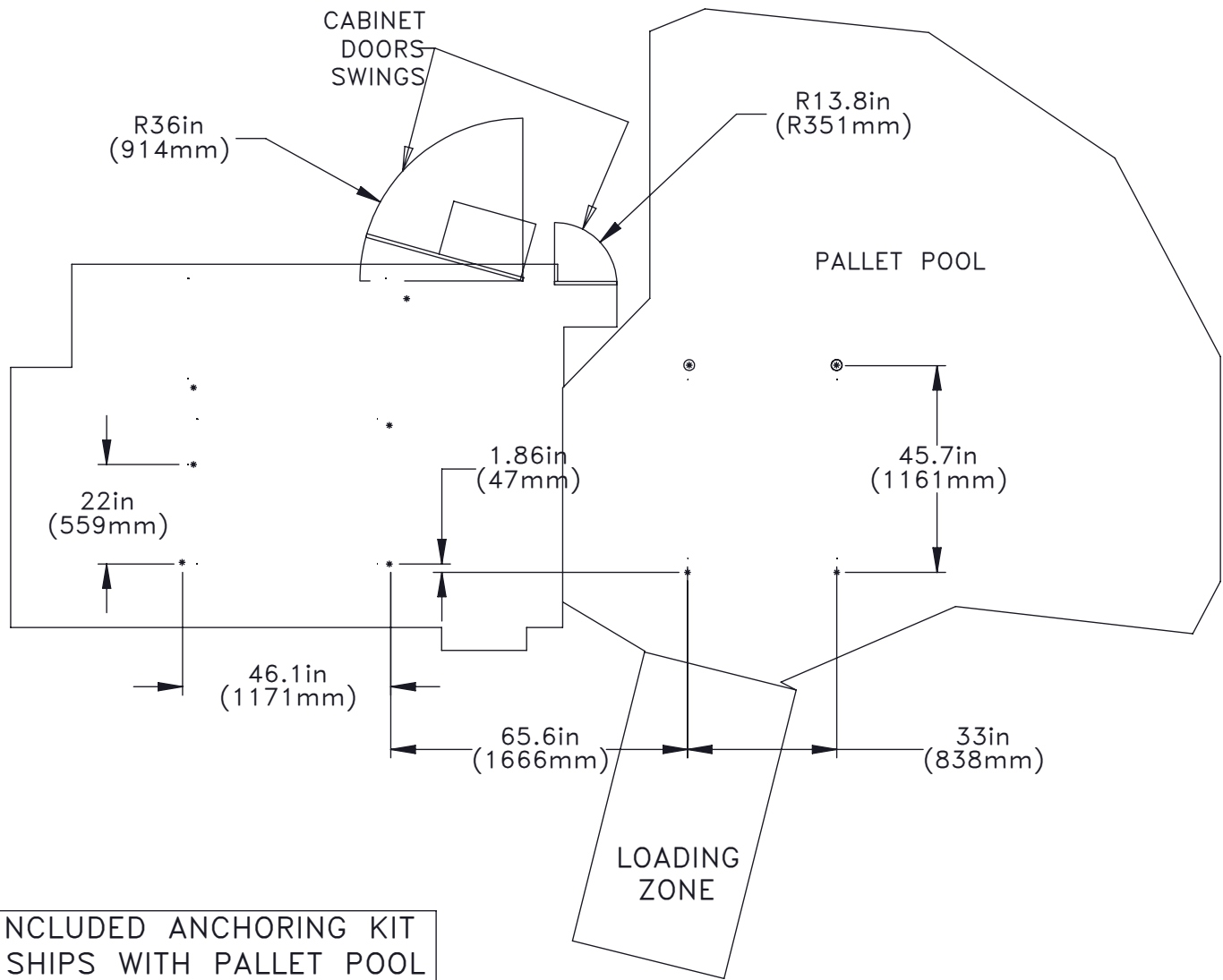

SHIPPING DIMENSIONS

- 1) Shipping weights and dimensions are posted with the PP specifications
- 2) The 5+1 Pallet Pool ships in many crates
- 3) One main pallet with the loading station and the PP base

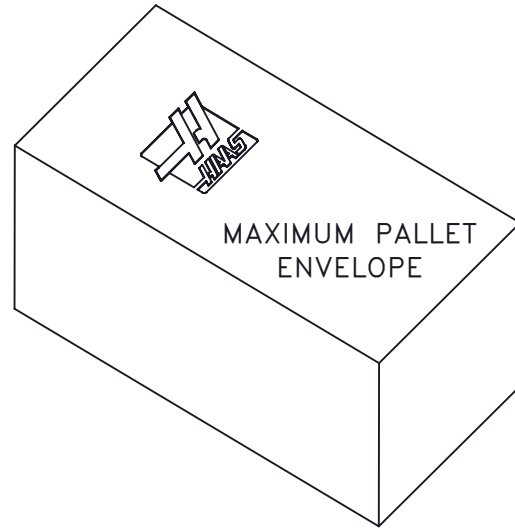
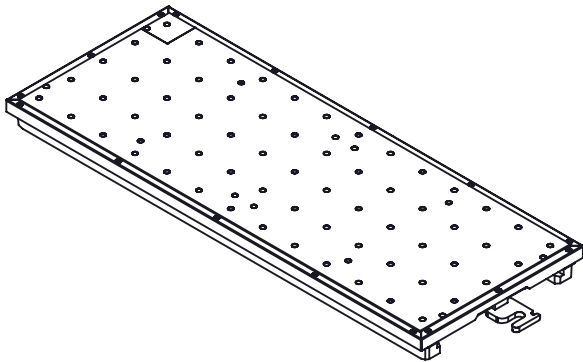

MAXIMUM PART WEIGHT:
750lbs (340kg)
(Workholding + Part)

47.75in X 20.35in X 20in
LENGTH x WIDTH x HEIGHT
(Workholding + Part)

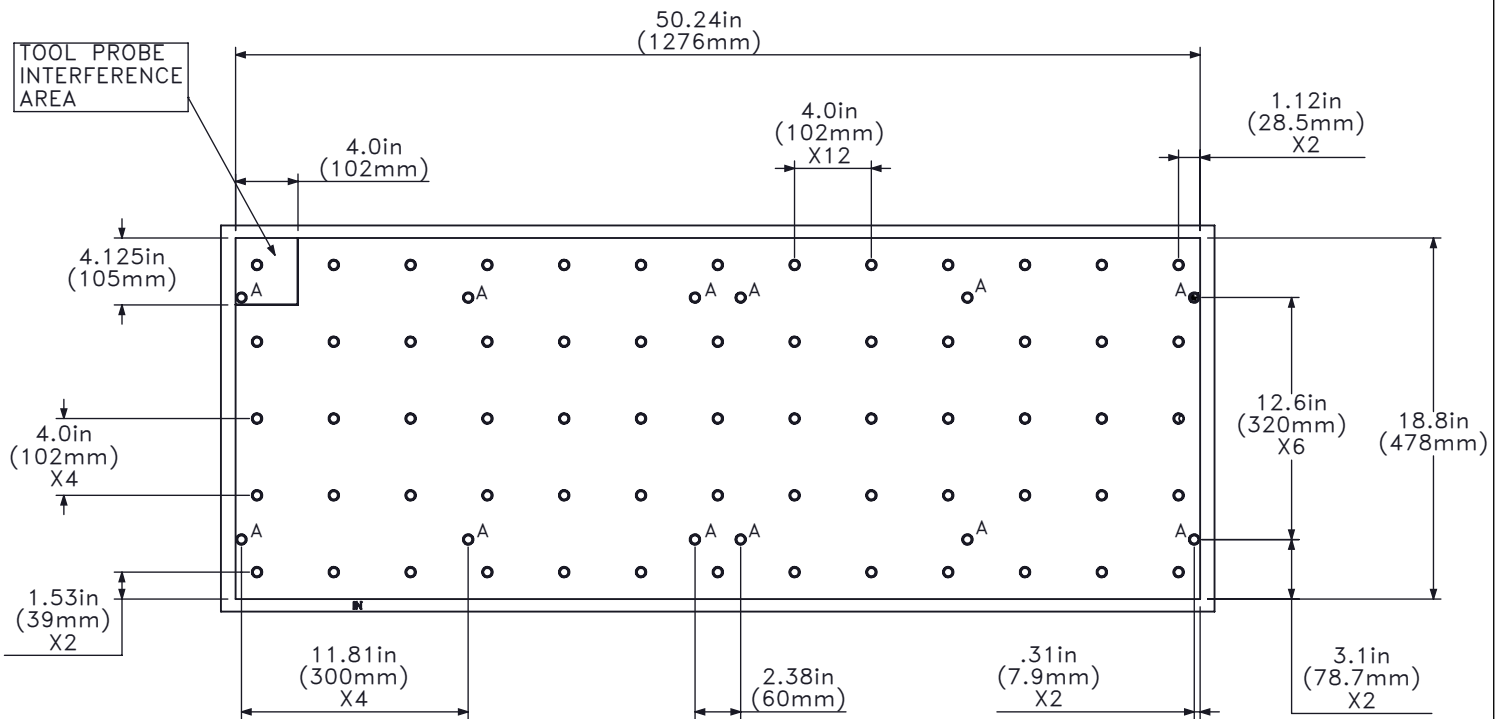

"A" THREADED HOLES ARE FOR FIXTURE PLATES
ALL OTHER THREADED HOLES ARE A 4.0in X 4.0in PATTERN

THREAD SIZE AND DENOMINATION:
1/2-13 UNC X .75in (19mm) DEEP
77 PLACES

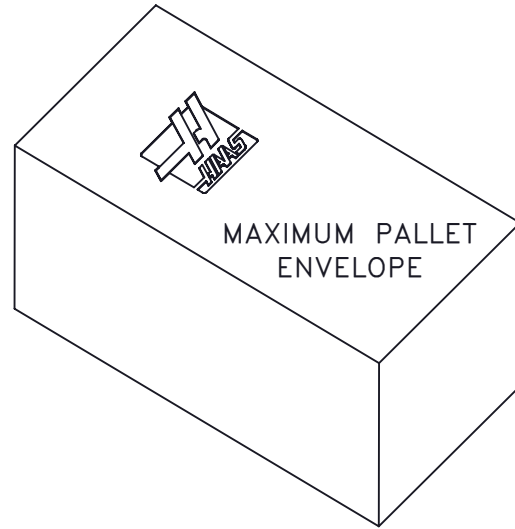
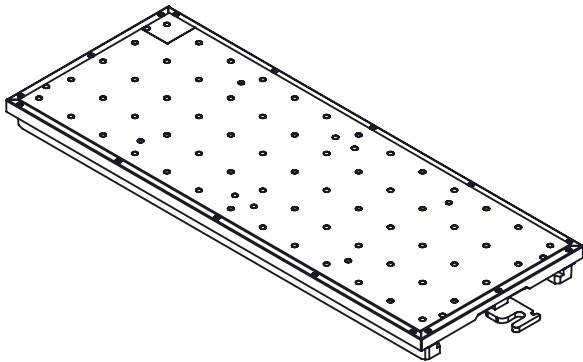

MAXIMUM PART WEIGHT:
340kg (750lb)
(Workholding + Part)

1213mm X 517mm X 508mm
LENGTH x WIDTH x HEIGHT
(Workholding + Part)

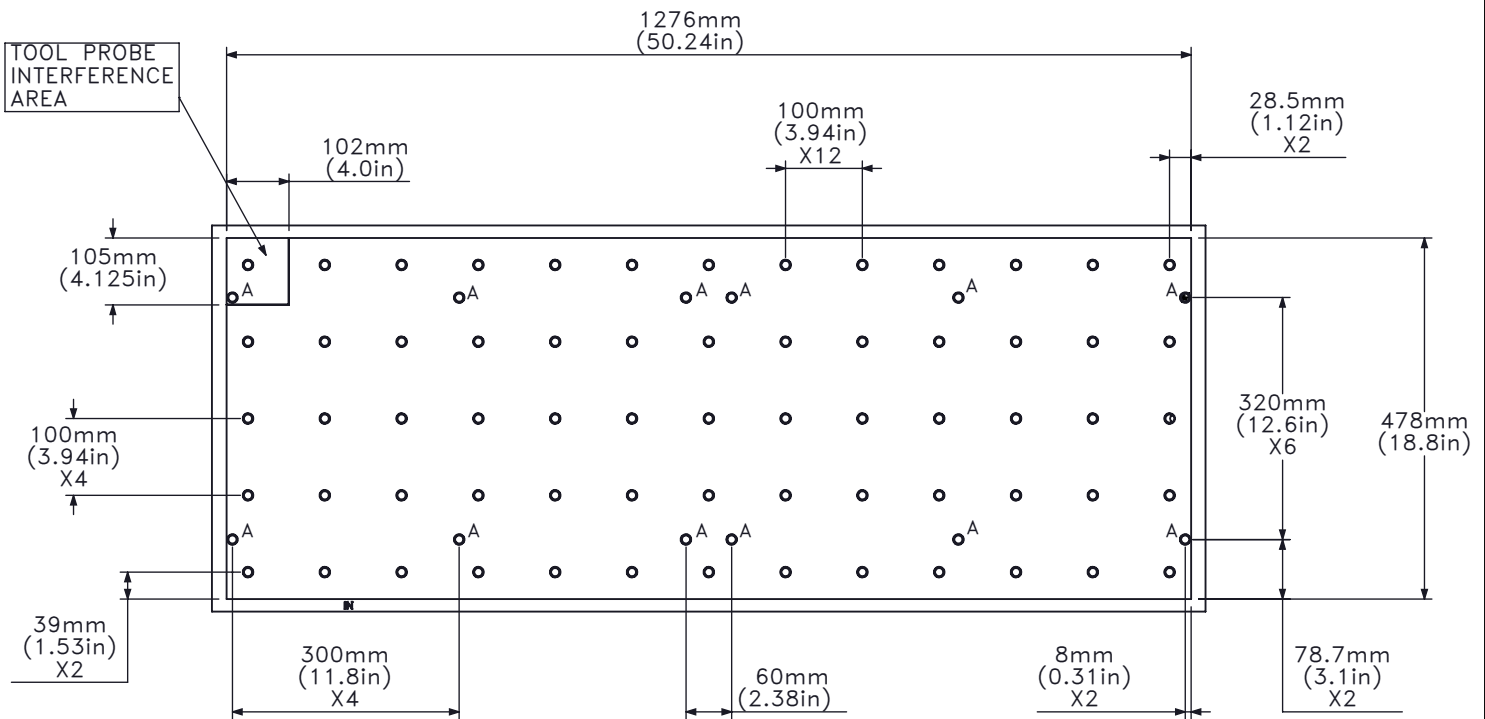

"A" THREADED HOLES ARE FOR FIXTURE PLATES
ALL OTHER THREADED HOLES ARE 100mm X 100mm PATTERN

THREAD SIZE AND DENOMINATION:
M12 X 1.75 X 19mm DEEP
77 PLACES