

Shipping Dimensions

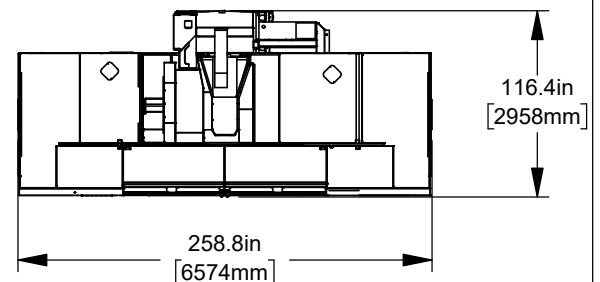

Note -
50+1 SMTC Shown
30+1 SMTC not available on this model

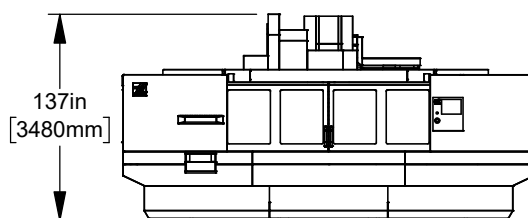
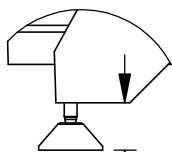

4.0in
[102mm]
Recommended

Air & Power

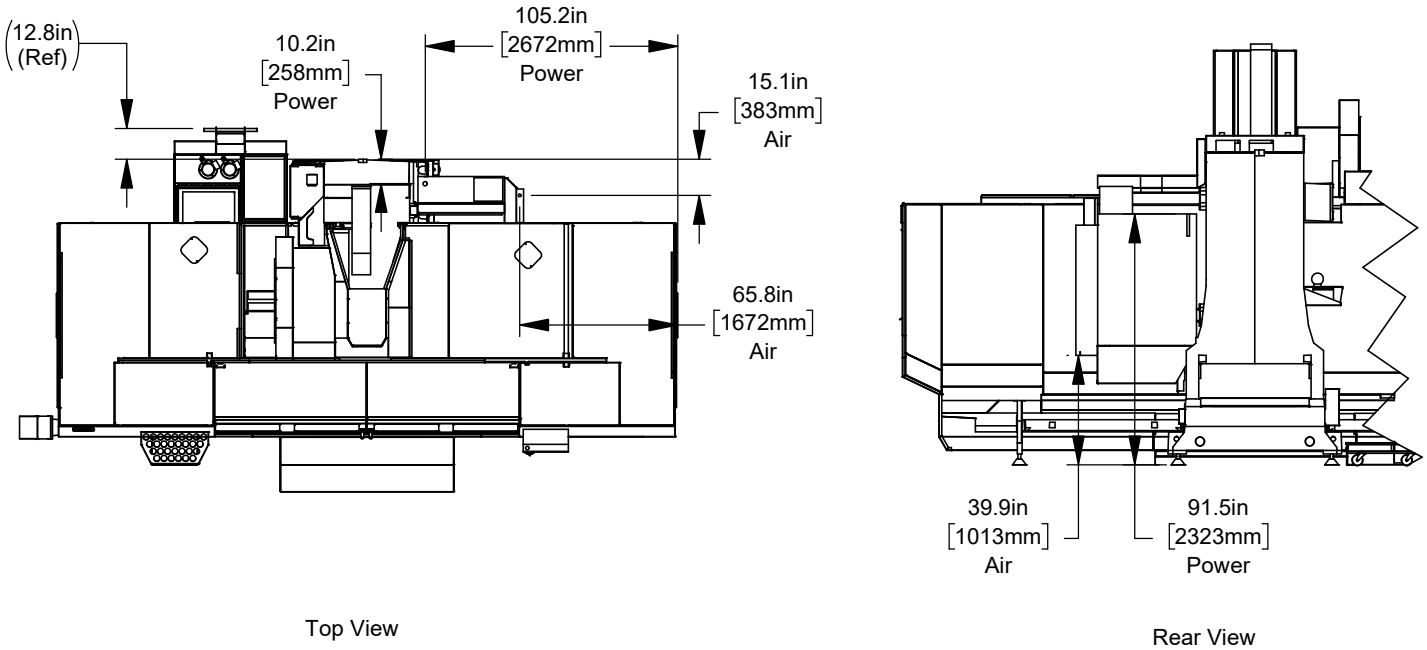

Anchor Pattern

Anchor Detail
 Ø .625in [16mm]
 ▽ 3.5in [89mm]

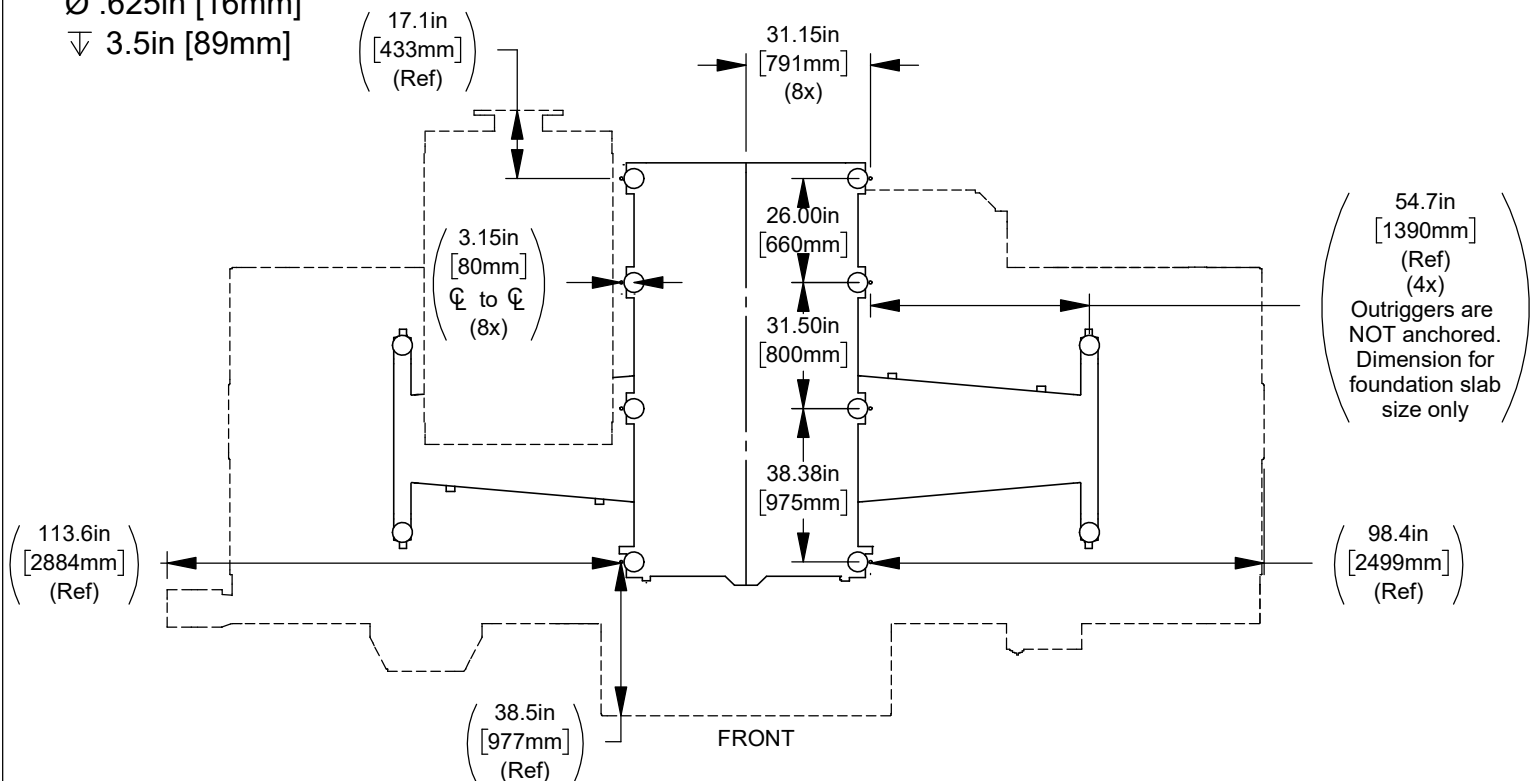

Height Breakdown

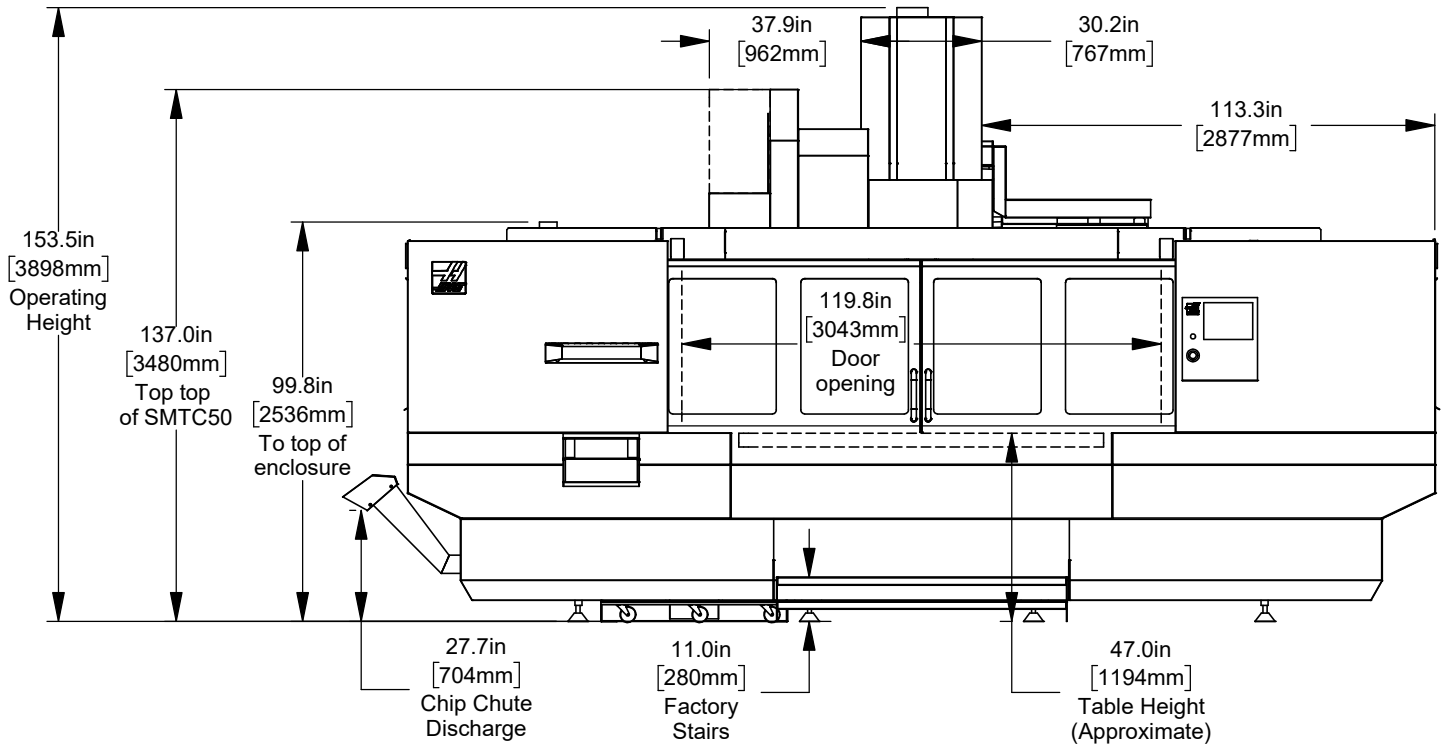

Width Breakdown

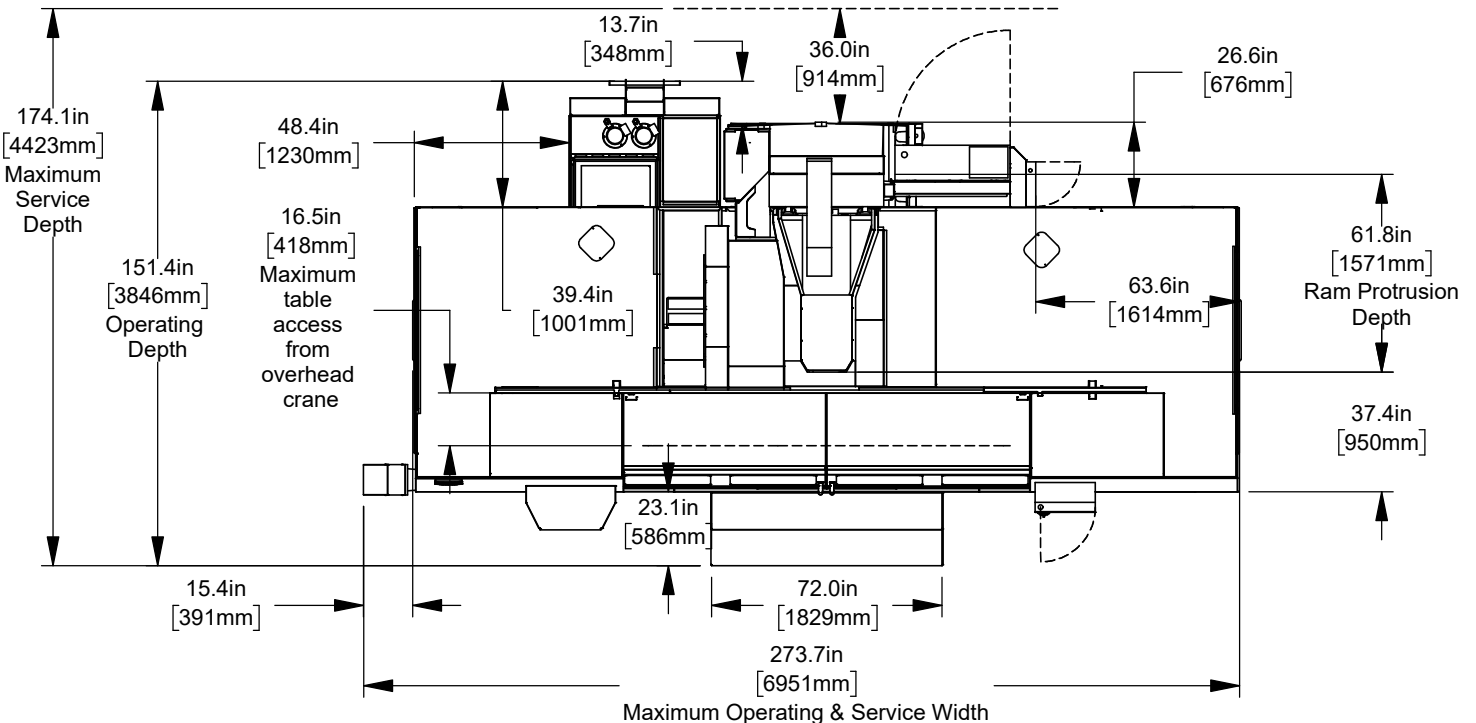

Maintain 3 feet [915mm] clearance to the nearest obstruction around all sides of machine perimeter for maintenance access

X & Y-Axis Travel at B0

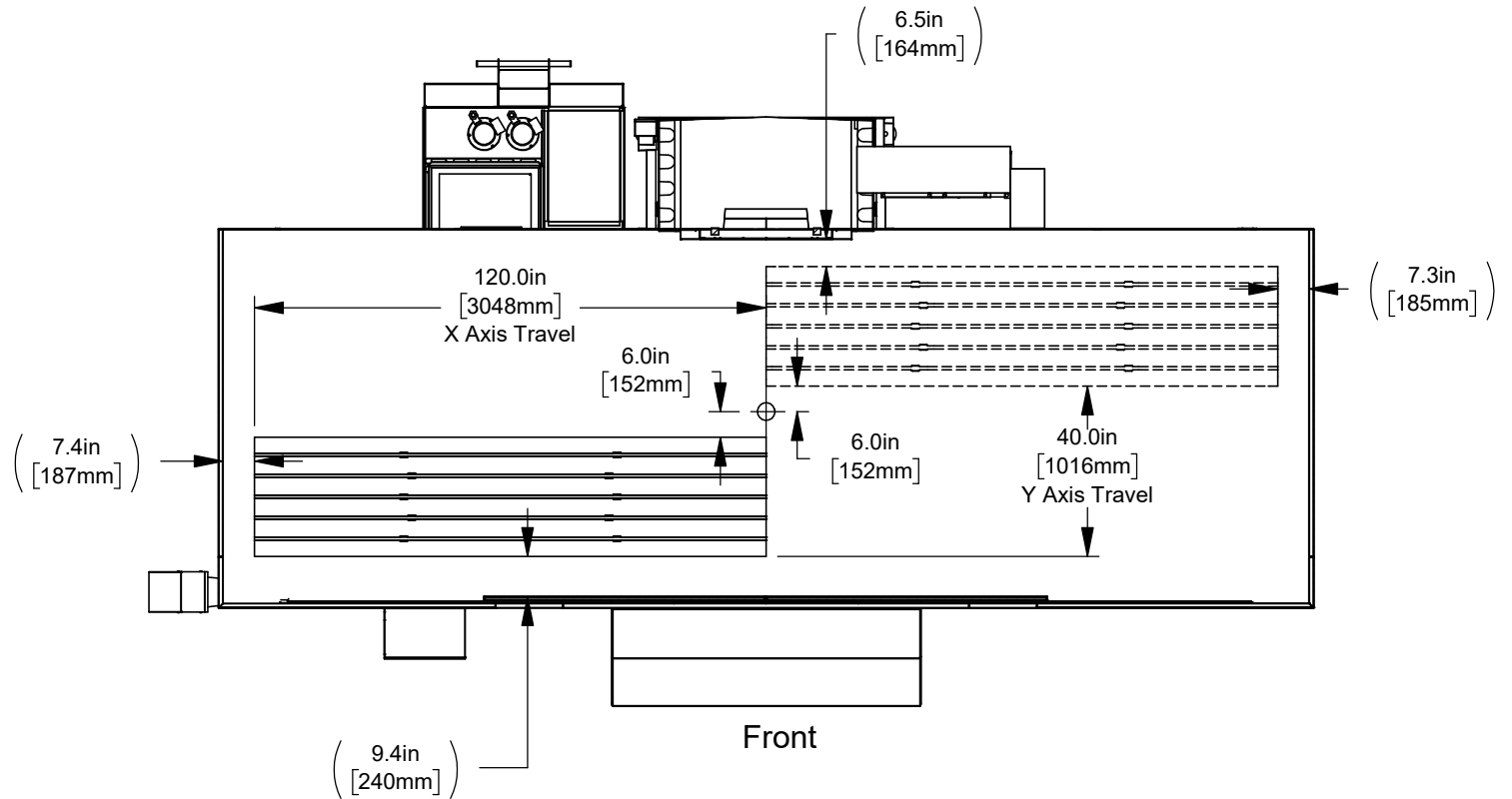

B & C axis Travel

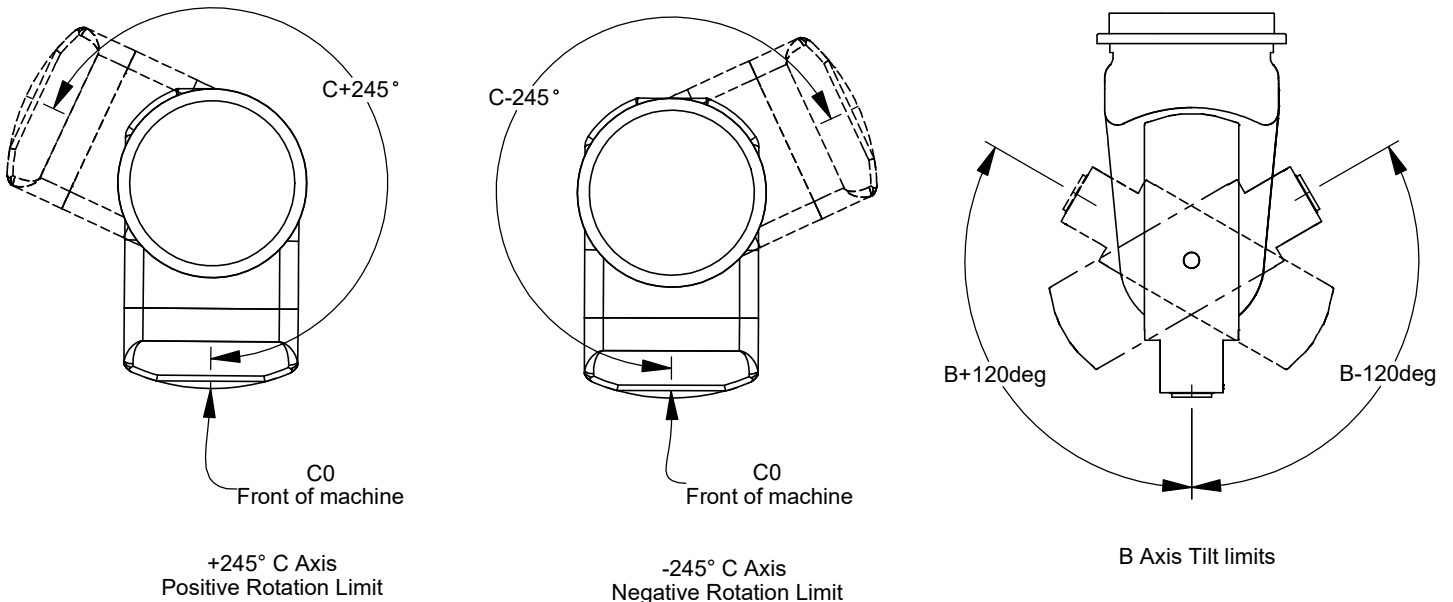

Isometric view of B & C Axis gimbal head for visual reference

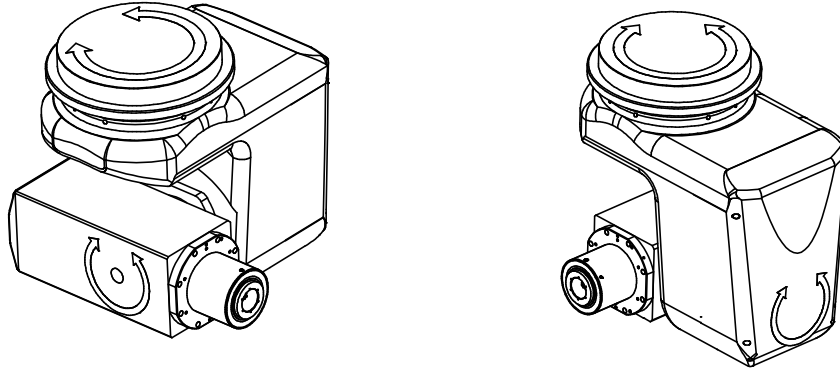

X&Y-Axis Clearance at B90 with C at 0, 90, -90, and 180

Notes -

The schematic shows the B90° work envelope with no tool in the spindle.

Depending on the part size and how many faces require machining, the part may need to be centered or offset to one side of the table.

Subtract (the longest tool length required on each side of the part) + (clearance) from the travels shown below to determine the maximum size workpiece based on your tooling requirements

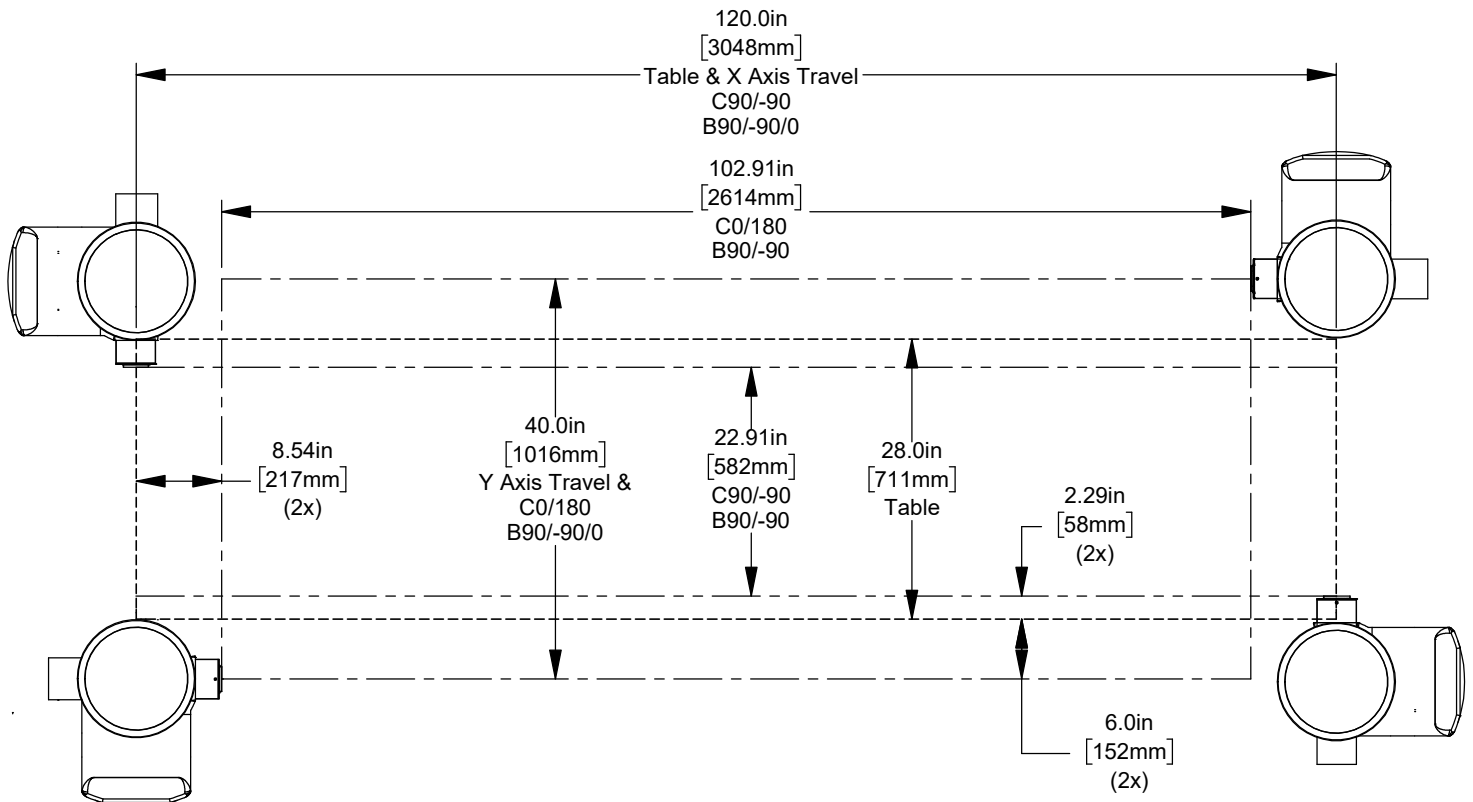

Table

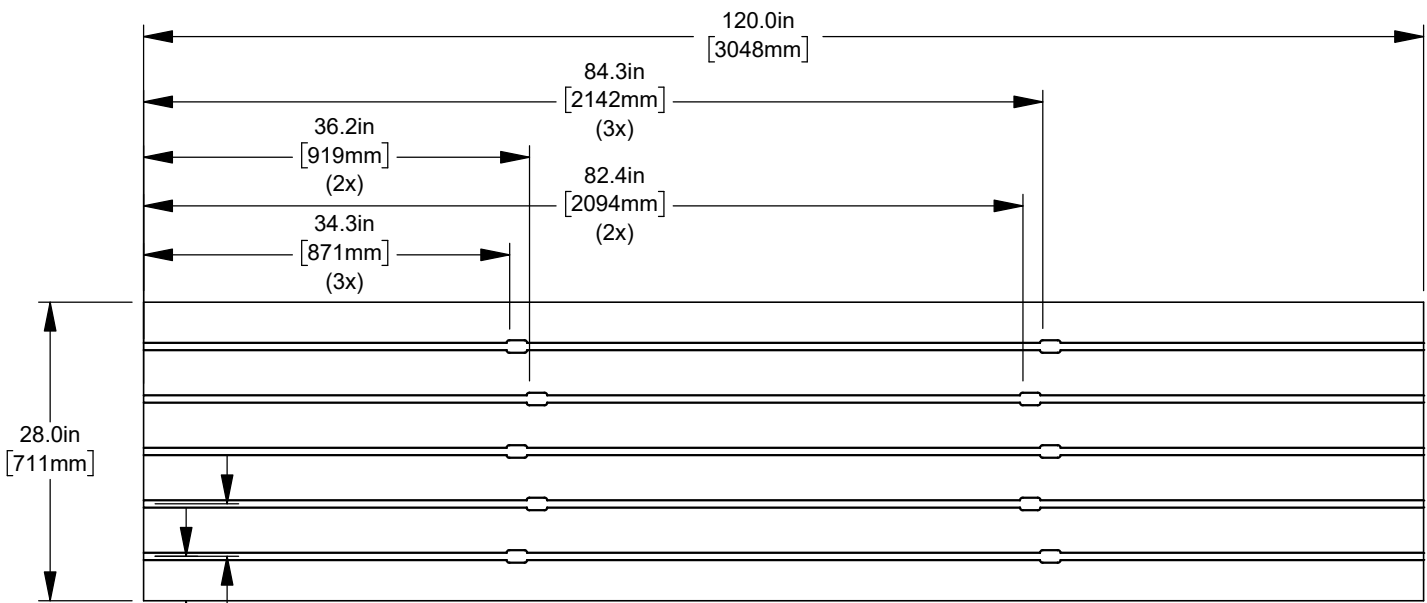

4.160in [105.7mm] Table edge to T-Slot \varnothing (2x)

4.920in [125.0mm] T-Slot \varnothing to \varnothing

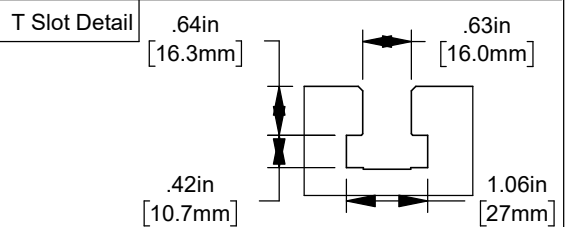
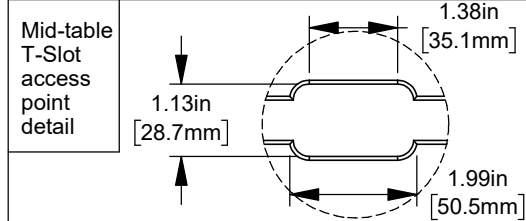

Tool Changer and Z Travel

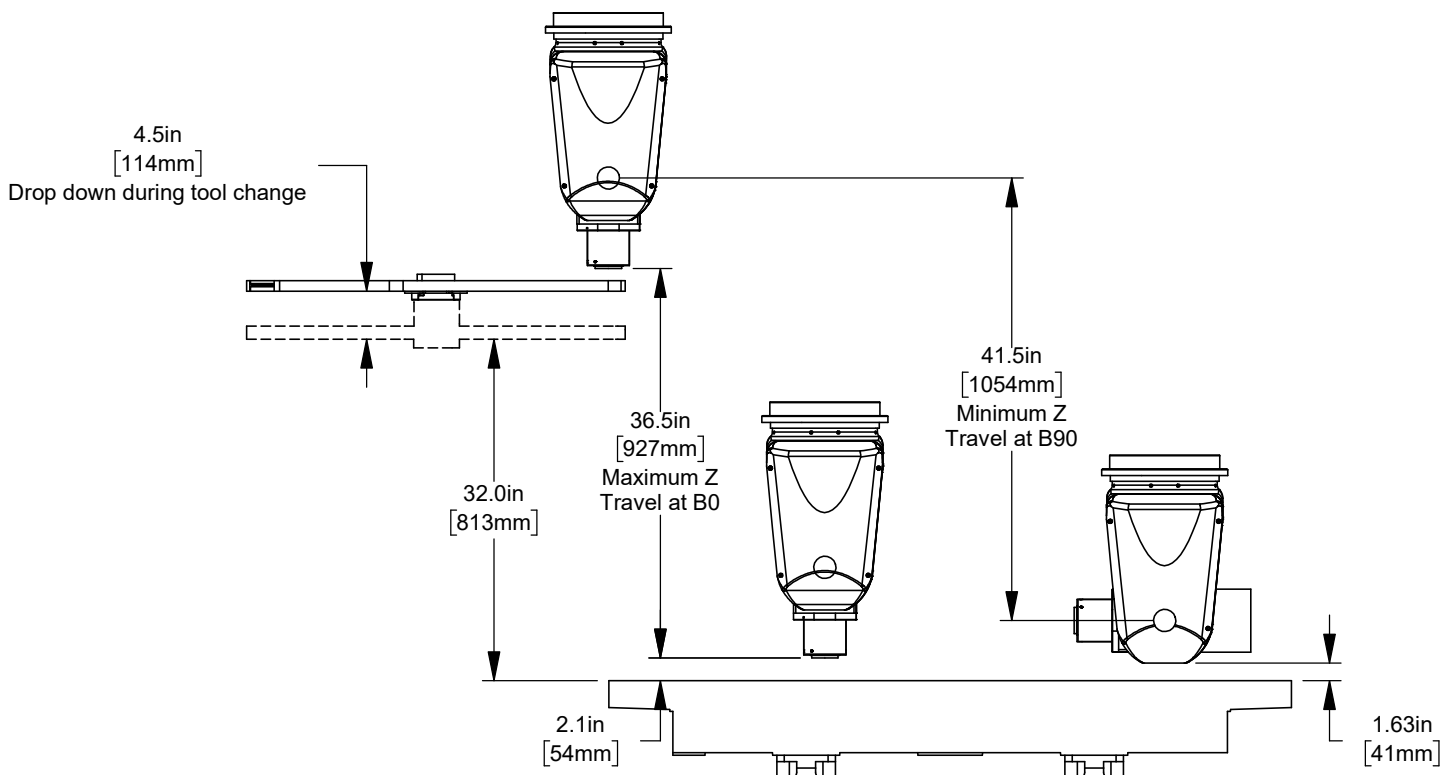

Restricted zones

NOTE- Spindle must be empty before Powerup/Restart is performed or the B axis may crash the tool changer

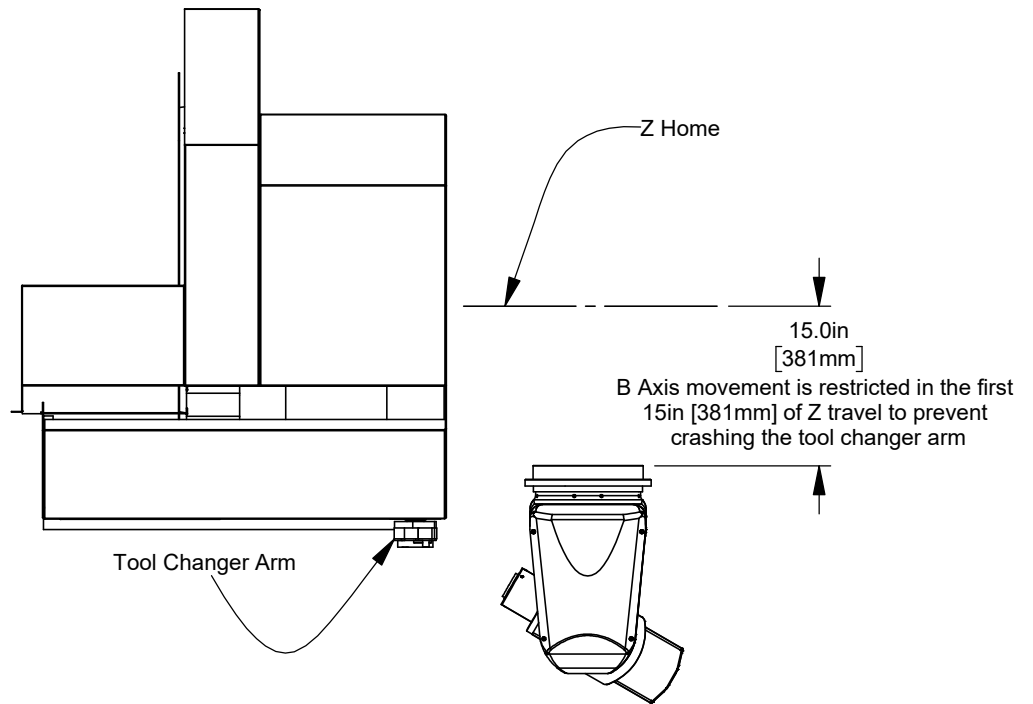

In addition to the tool changer interference zone, the machine has restricted zones between the gimbal head and fixed machine elements

When Setting 408 = 1 the interference zones account for the tool length based on its Z geometry in the offset table

When Setting 408 = 0 the tool length is not considered in the interference zones

Potential interference at maximum Z travel with Z axis casting

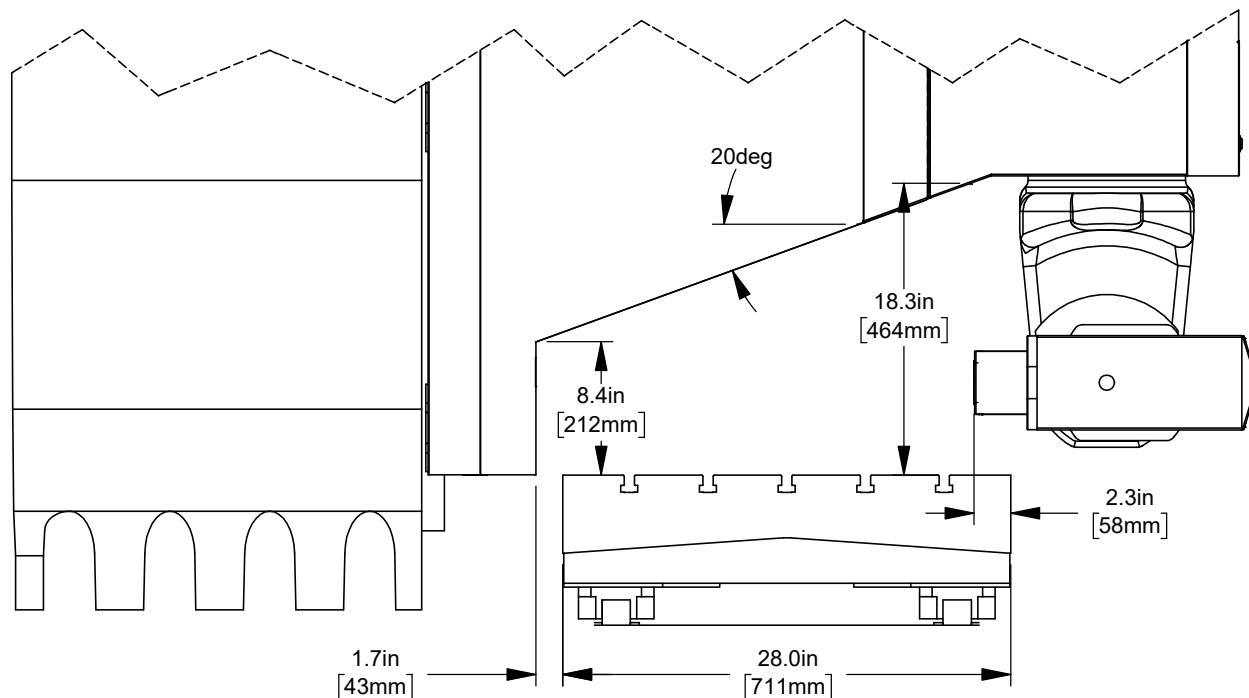

Minimum Z height to reach B120°

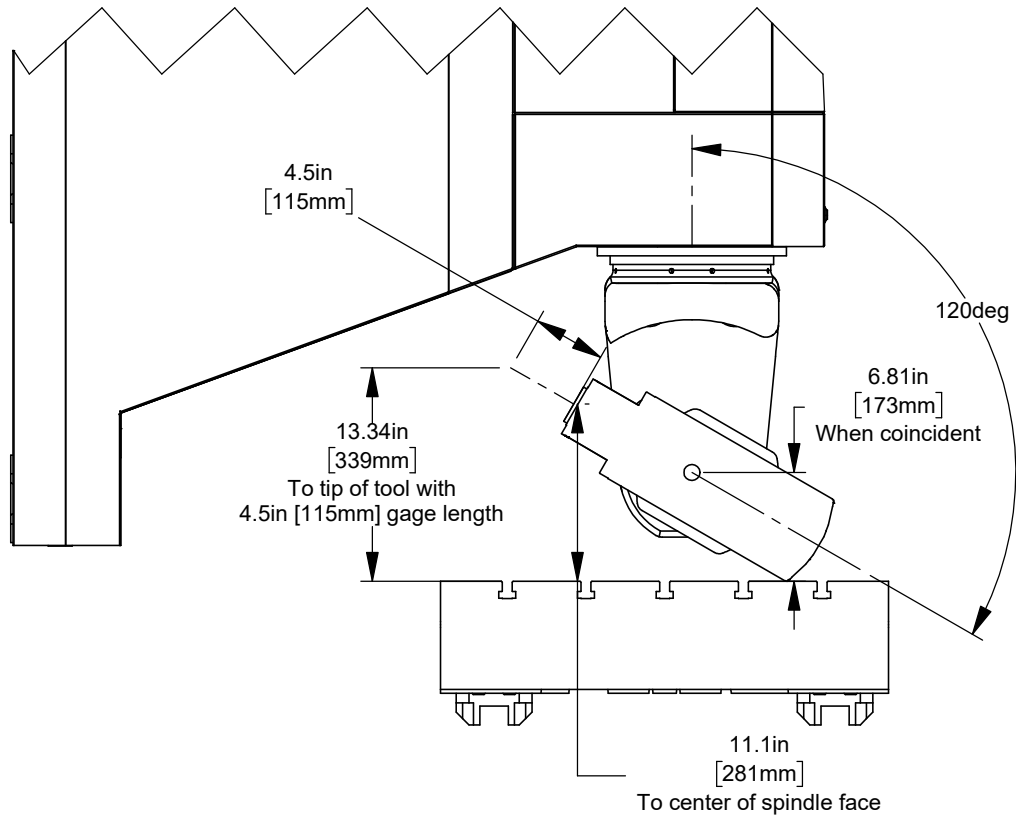

Gimbal Head Detail

