

Haas Automation

Installation Instructions

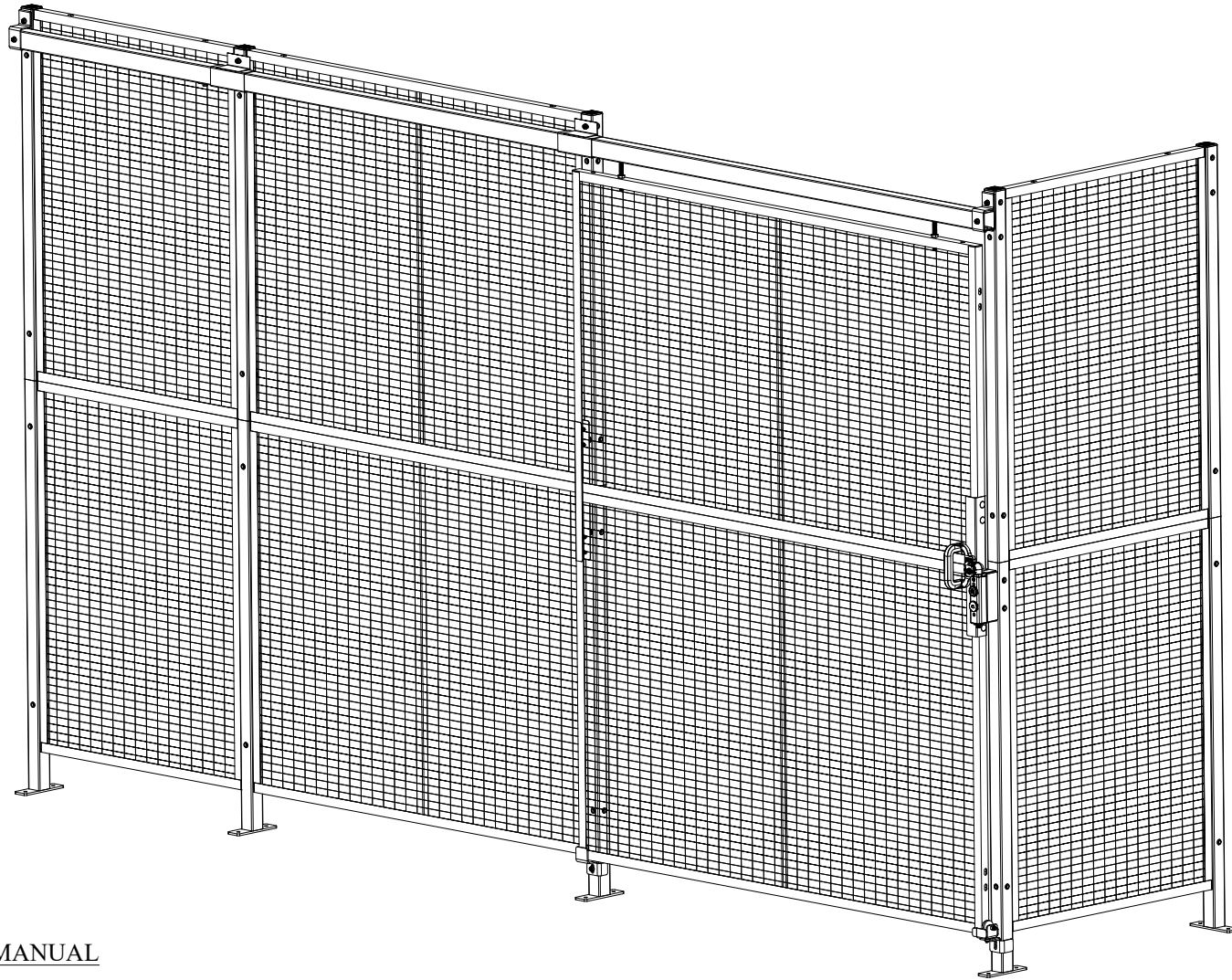

INCLUDED IN THIS MANUAL

<u>Description</u>	<u>Page</u>
Panels and Posts	2
Door Assembly	3
Door Assembly Figures	4-5

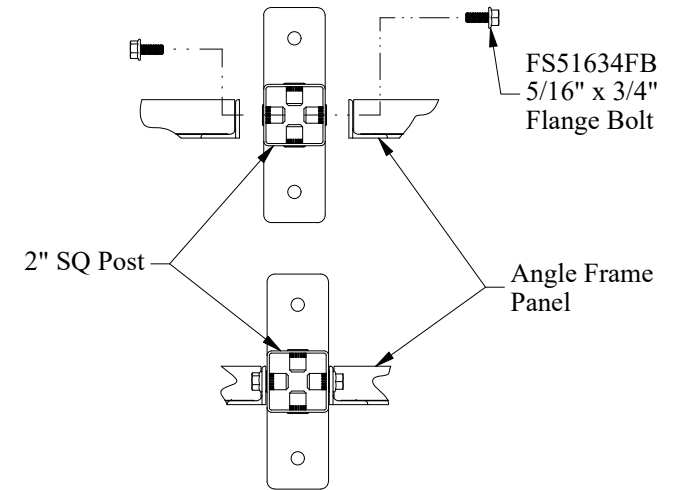
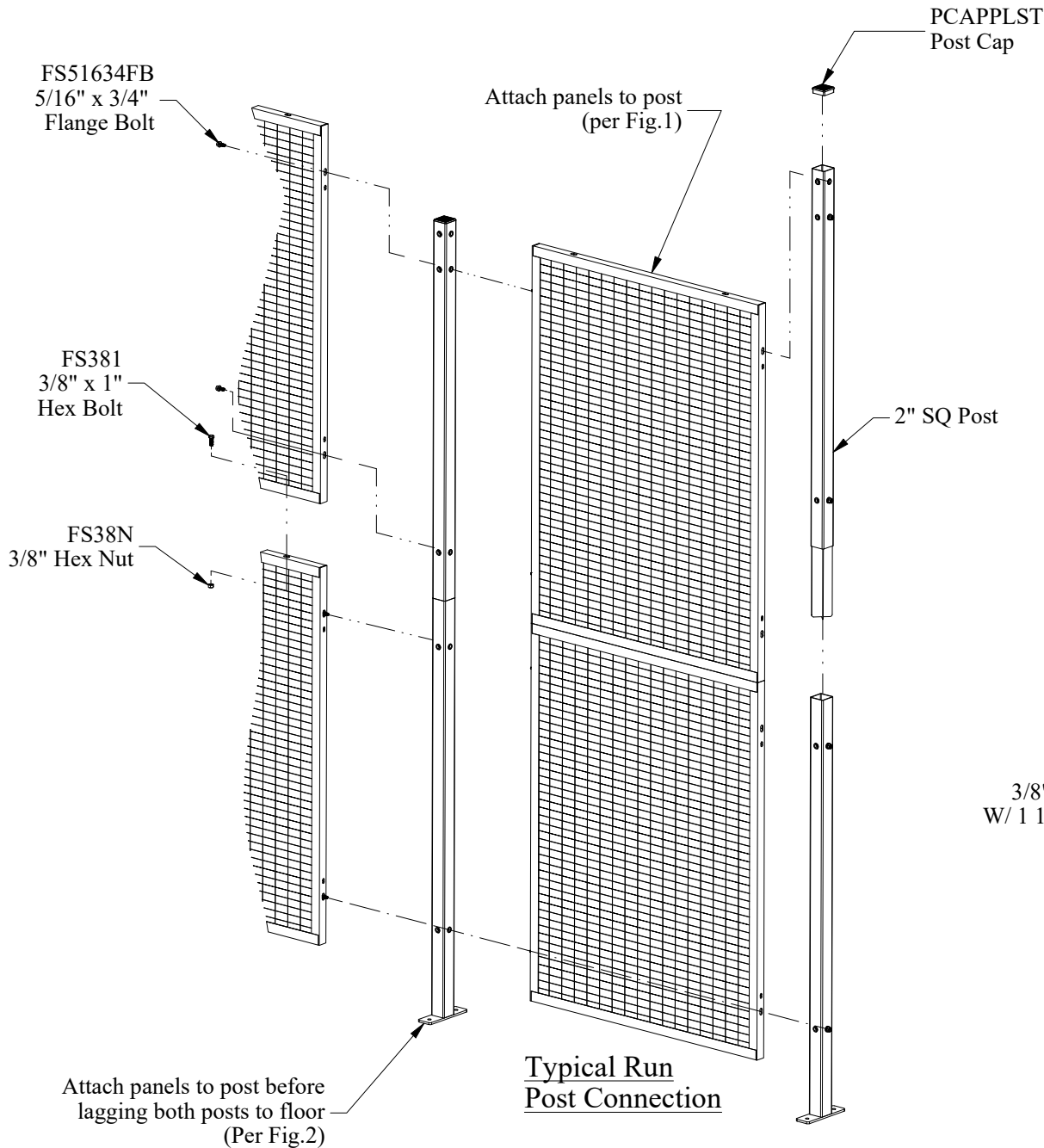

Fig. 1

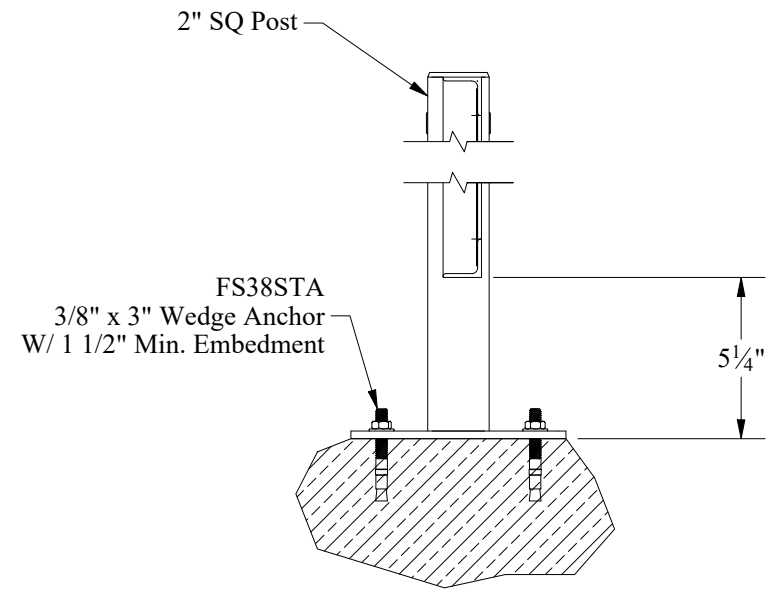
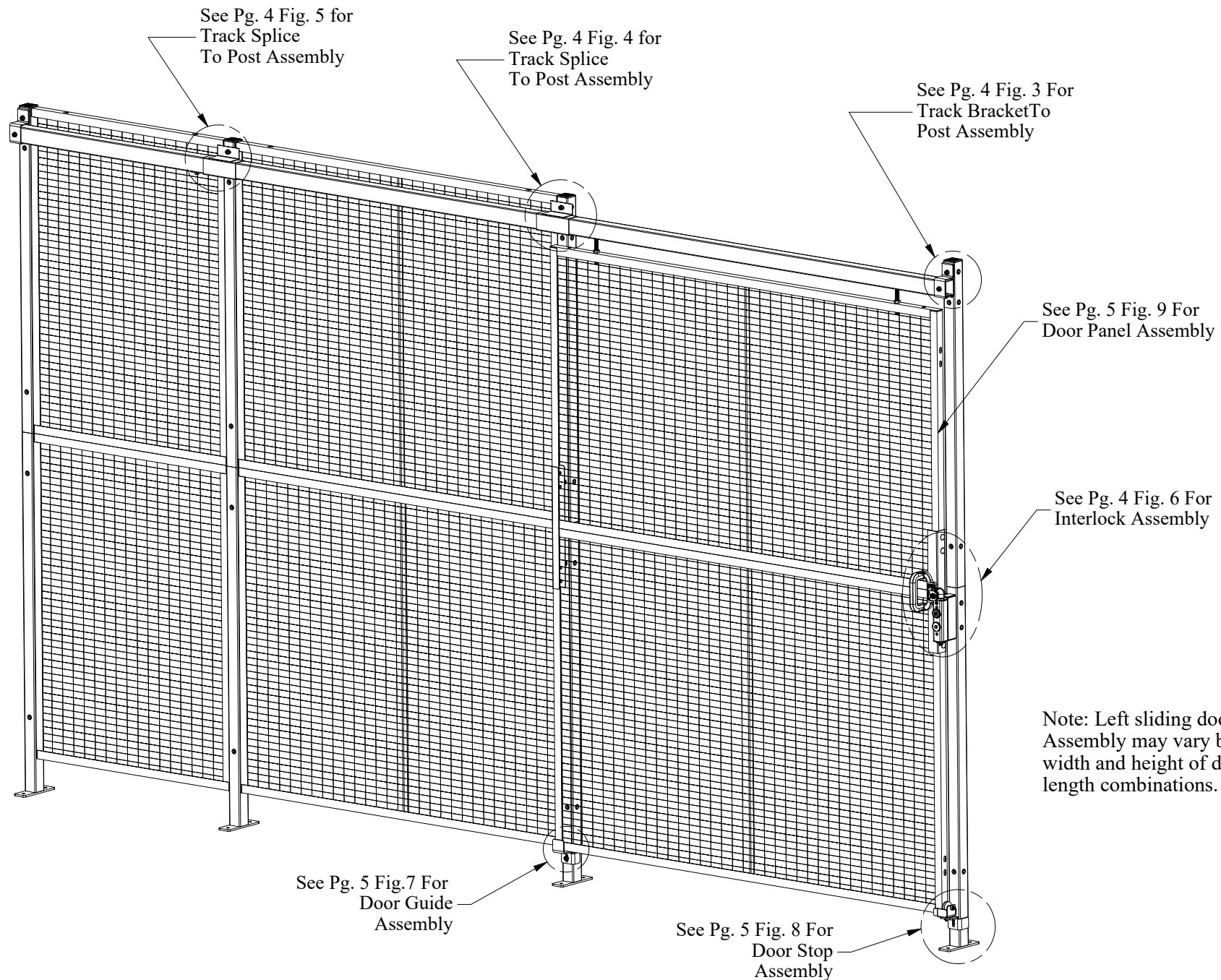
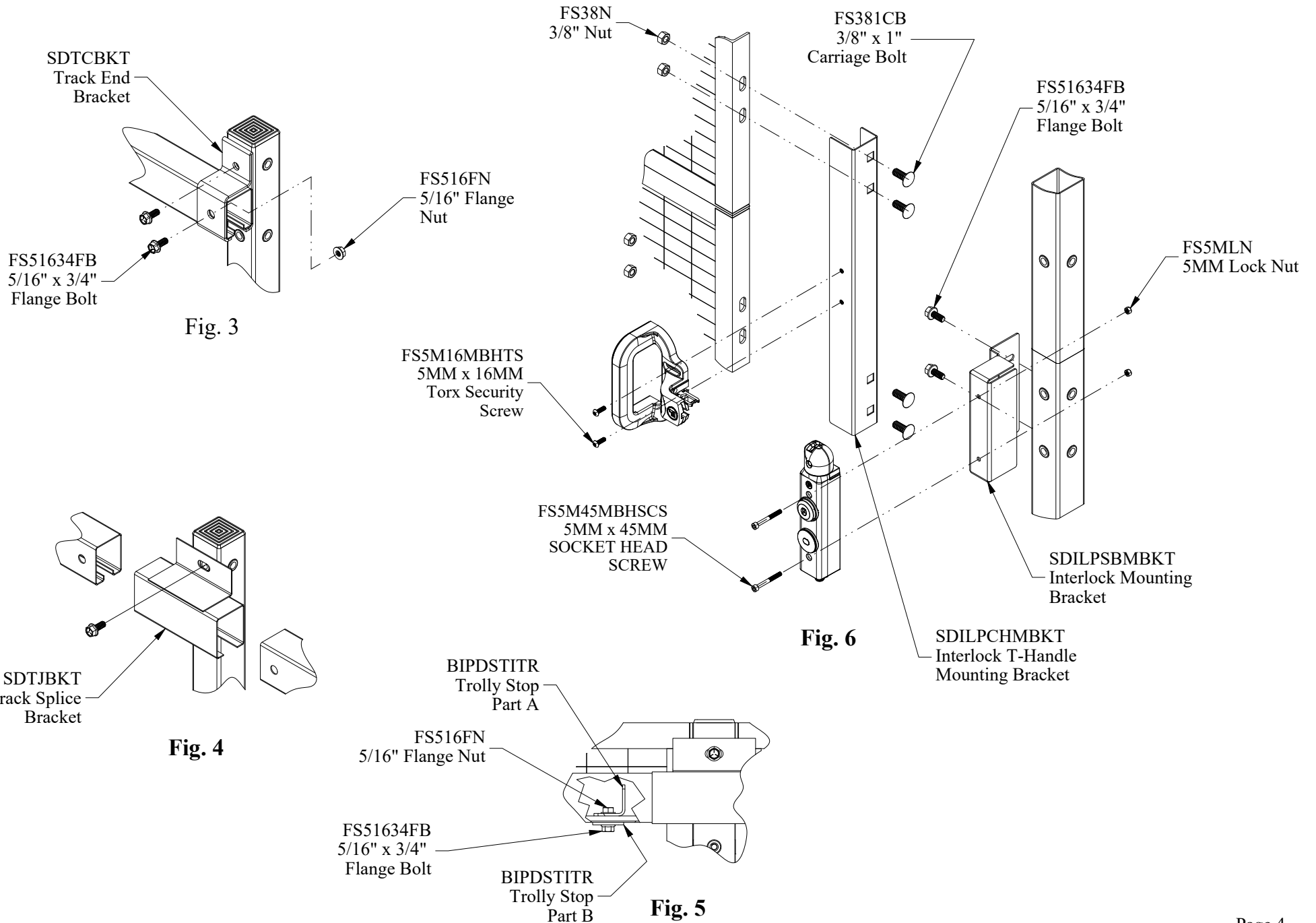

Fig.2





Note:
See plan and elevation
views for "stack"
dimensions
of door panels

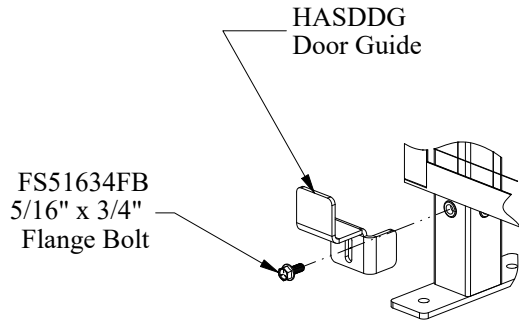

Fig. 7

FS381
3/8" x 1"
Carriage Bolt

FS38N
3/8" Nut

SDDEPCH
Splice Channel

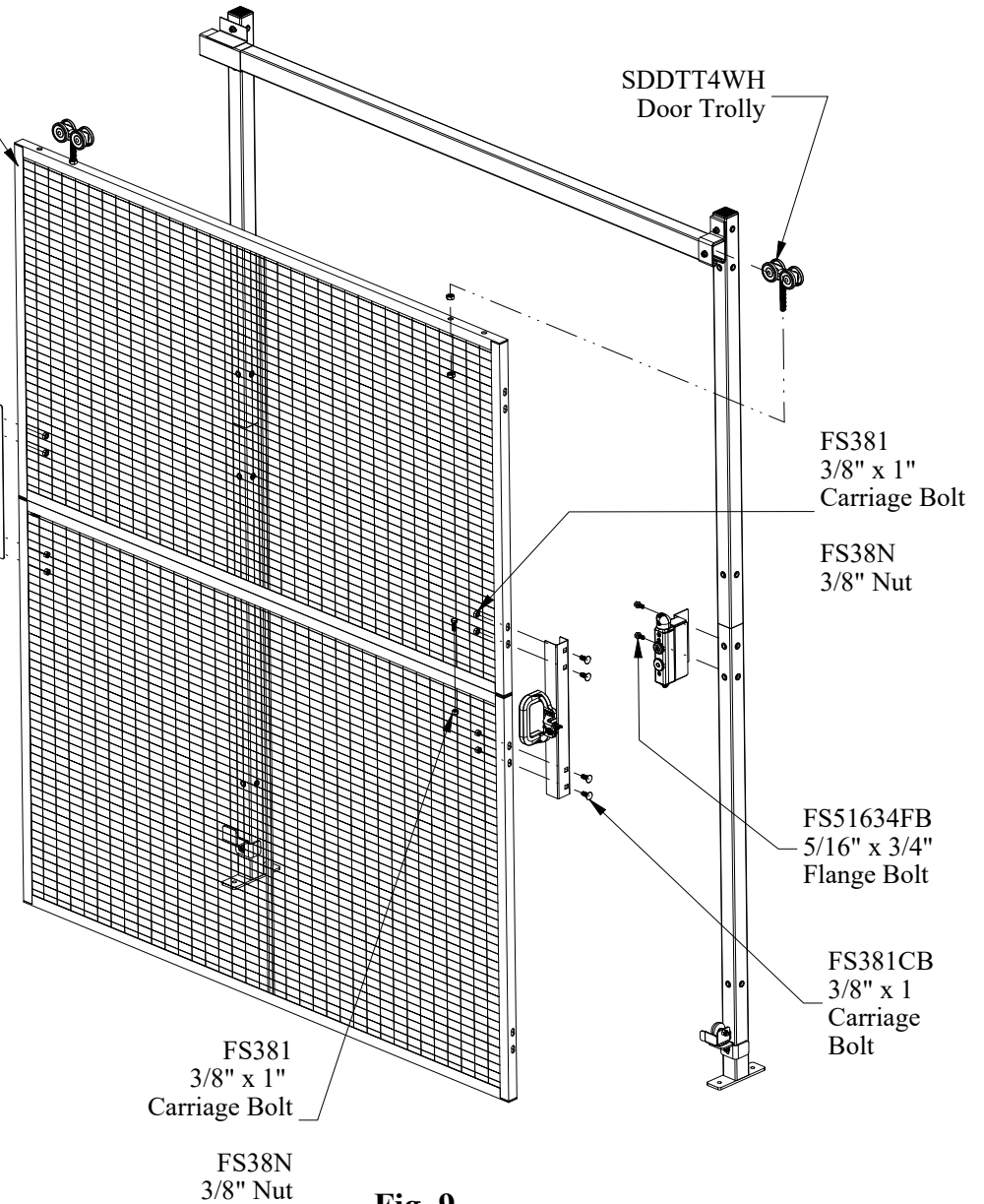

Fig. 9

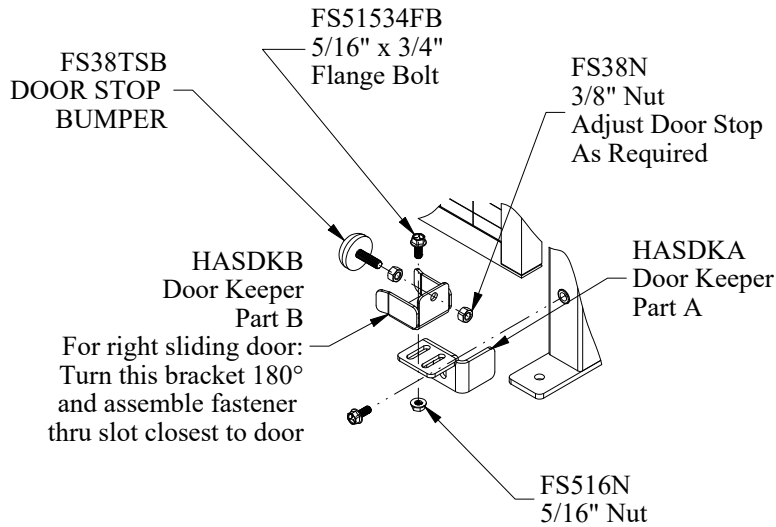

Fig. 8
Left Sliding Door shown

Thanks for using

WireCrafters

Machine Guarding

For more information on WireCrafters products please visit our website at www.machineguarding.com