

UMC-1 000 INSPECTION REPORT

1

INSPECTOR	
DATE	
SERIAL #	

1. MACHINE LEVEL (NTE 0.0005" / 10" [0.013 mm / 250 mm])

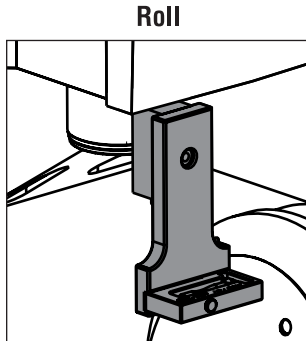
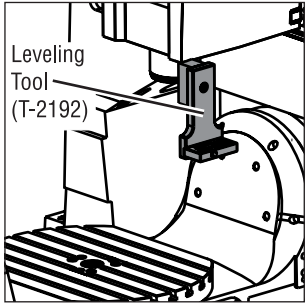

READ THE LEVEL AT RIGHT, CENTER, AND LEFT IN THE X-AXIS DIRECTION.

RECORD THE LARGEST READING.

MEASURED VALUE FOR THE X-AXIS:

Draw the bubble level indication for each position.

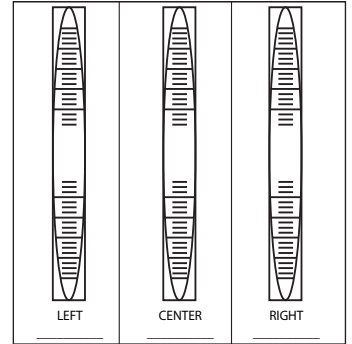

2. B-AXIS PARALLELISM TO Y-AXIS (NTE 0.0008" / 10" [0.025 mm / 250 mm] ; 0.0015" / 20" [0.05 mm / 500 mm])

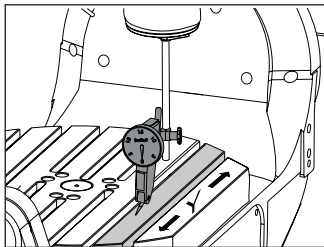

INDICATE THE TOP OF THE PLATTER IN THE Y-AXIS.

PARALLELISM IN Y/Z PLANE:

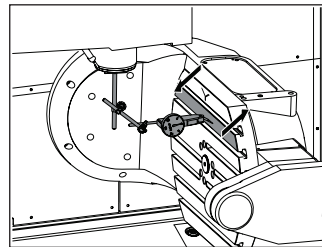

ROTATE B 90°. INDICATE THE SAME SURFACE IN THE Y-AXIS.

PARALLELISM IN X/Y PLANE:

3. SQUARENESS OF X/Y AXIS (NTE 0.0005" / 10" [0.013 mm / 250 mm])

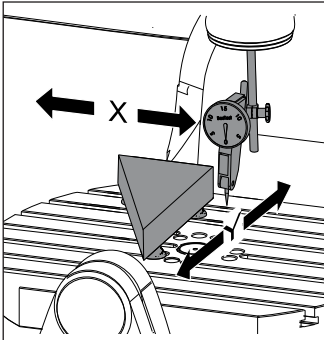

SET GRANITE FLAT TO X/Y PLANE NTE 0.0002"

SQUARENESS: _____

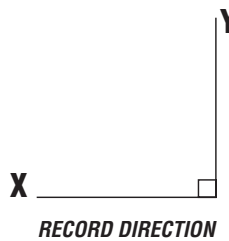

4. SQUARENESS OF X-AXIS TO Z-AXIS (NTE 0.0005" / 10" [0.013 mm / 250 mm])

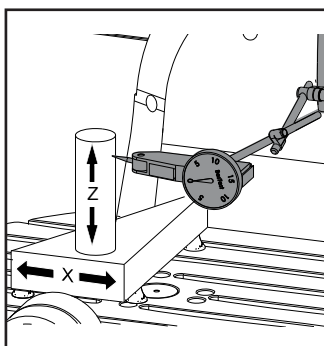

TOP OF CYLINDER FLAT TO X/Z PLANE NTE 0.0002"

SQUARENESS: _____

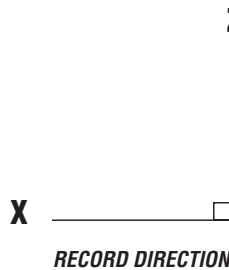

5. SQUARENESS OF Y-AXIS TO Z-AXIS (NTE 0.0005" / 10" [0.013 mm / 250 mm])

TOP OF CYLINDER FLAT TO X/Y NTE 0.0002"

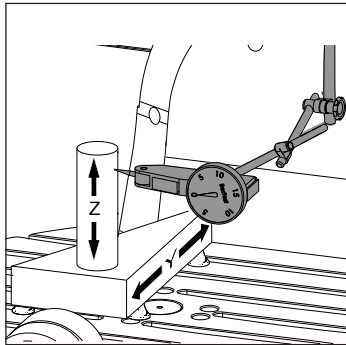

SQUARENESS: _____

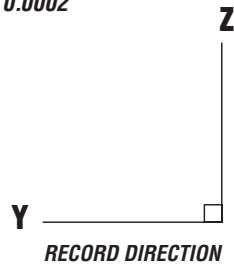

6. C-AXIS PERPENDICULARITY TO X/Y PLANE

CHECK SINGLE POINT AT 4 POSITIONS, 90 DEGREES APART AT EDGE OF PALLET AS SHOWN: (ROTATE PLATTER 90 DEG CW THEN JOG AXIS TO INDICATE POINT, RECORD READING & REPEAT EVERY 90 DEG)

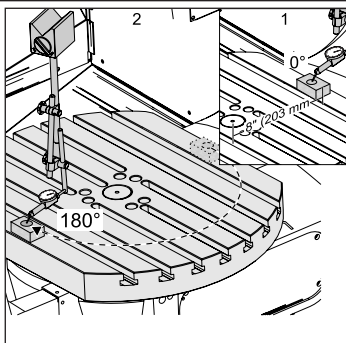

0° _____ C/X ⊥ = _____ (NTE 0.0005" [0.013 mm])

90° _____

180° _____ C/Y ⊥ = _____ (NTE 0.0005" [0.013 mm])

270° _____

7. PLATTER FACE RUNOUT (NTE 0.001" [0.025 mm] TIR)

CHECK 4 POINTS, 90° APART ON FACE OF PLATTER AND APPROXIMATELY 1/2" (13 mm) FROM THE PLATTER EDGE. INDICATE RUNOUT AT 0° POSITION (JOG AXIS TO LOCATE INDICATOR AT 0° POSITION AND ZERO OUT INDICATOR; ROTATE PLATTER AT 90° INCREMENTS AND RECORD READINGS).

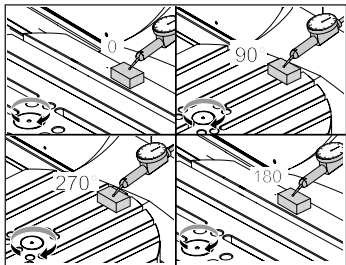

TIR: _____

8. FLATNESS OF PLATTER SURFACE (NTE 0.001" / 10" [0.025 mm / 250 mm] ; 0.002" / 20" [0.05 mm / 500 mm])

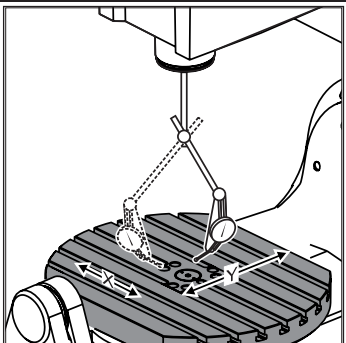

X-AXIS (+/-) _____

Y-AXIS (+/-) _____

9. CHECK SPINDLE RUNOUT

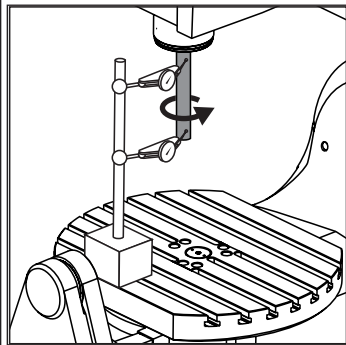

USE TEST BAR T-0050.

AT BASE OF BAR:
NTE 0.0005" TIR _____
(0.013 mm)

AT 6 INCHES FROM BASE:
NTE 0.001" TIR _____
(0.03 mm)

10. PARALLELISM OF SPINDLE CENTER LINE TO Z-AXIS MOVEMENT (NTE 0.0005"/10" [0.013 mm / 250 mm])

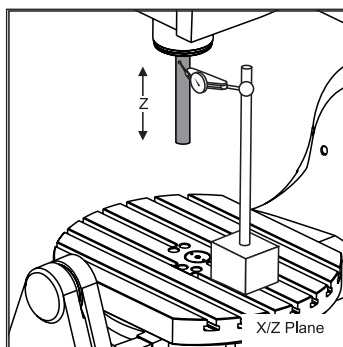
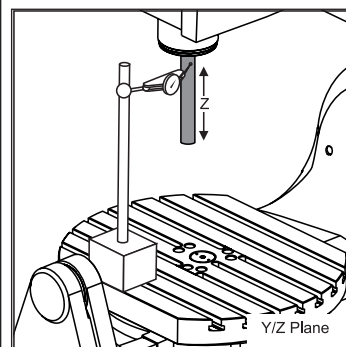

SPINDLE SWEEP

Y/Z _____

X/Z _____

11. CONCENTRICITY OF LOWER CENTER BORE (PLATTER)

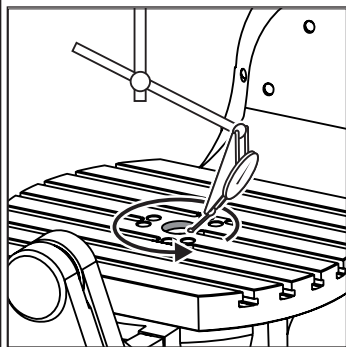

(NTE 0.005" TIR) _____
0.125 mm

12. MACHINE ROTARY ZERO POINT SETTINGS

USE THE VQC MACRO PROGRAM AND PROBE SYSTEM TO SET THE VALUES FOR THE COLDFIRE PARAMETERS OR THE NGC SETTINGS SHOWN IN THE TABLE.
(MACHINE ROTARY ZERO POINT X,Y,Z AXES AND 5 AXIS ROTARY CENTER POINT DISTANCE)

RECORD THE PARAMETER OR SETTING VALUES BELOW:

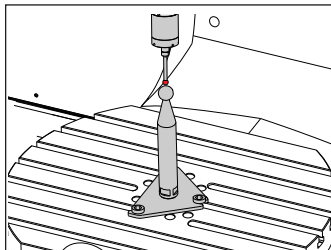

NGC SETTING	VALUE
255 - MRZP X OFFSET	
256 - MRZP Y OFFSET	
257 - MRZP Z OFFSET	
254 - 5 AXIS ROTARY CENTER POINT DISTANCE	