

TOOLING BLOCK 40 TAPER

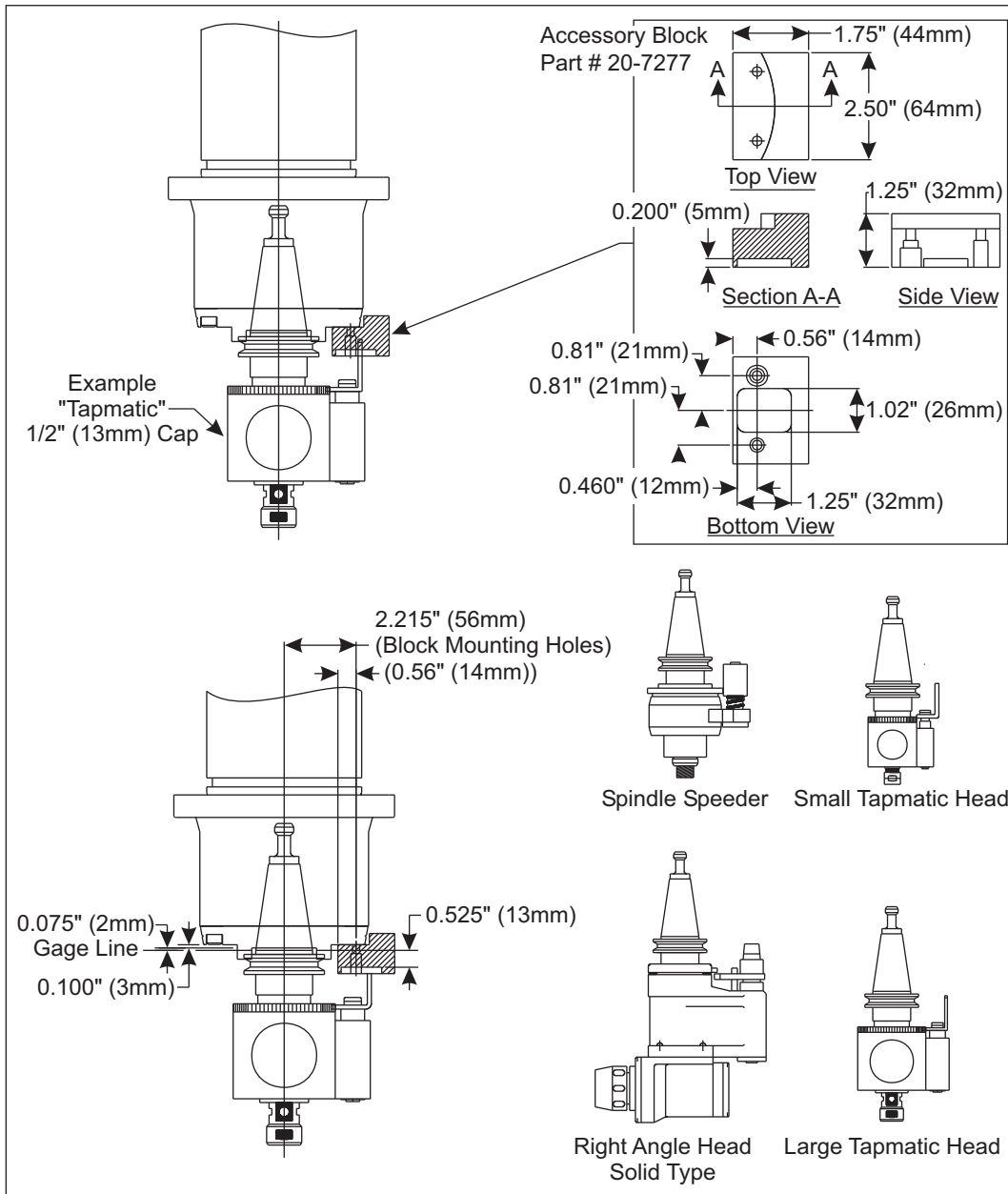

TOOLING BLOCK - SERPENTINE HEAD

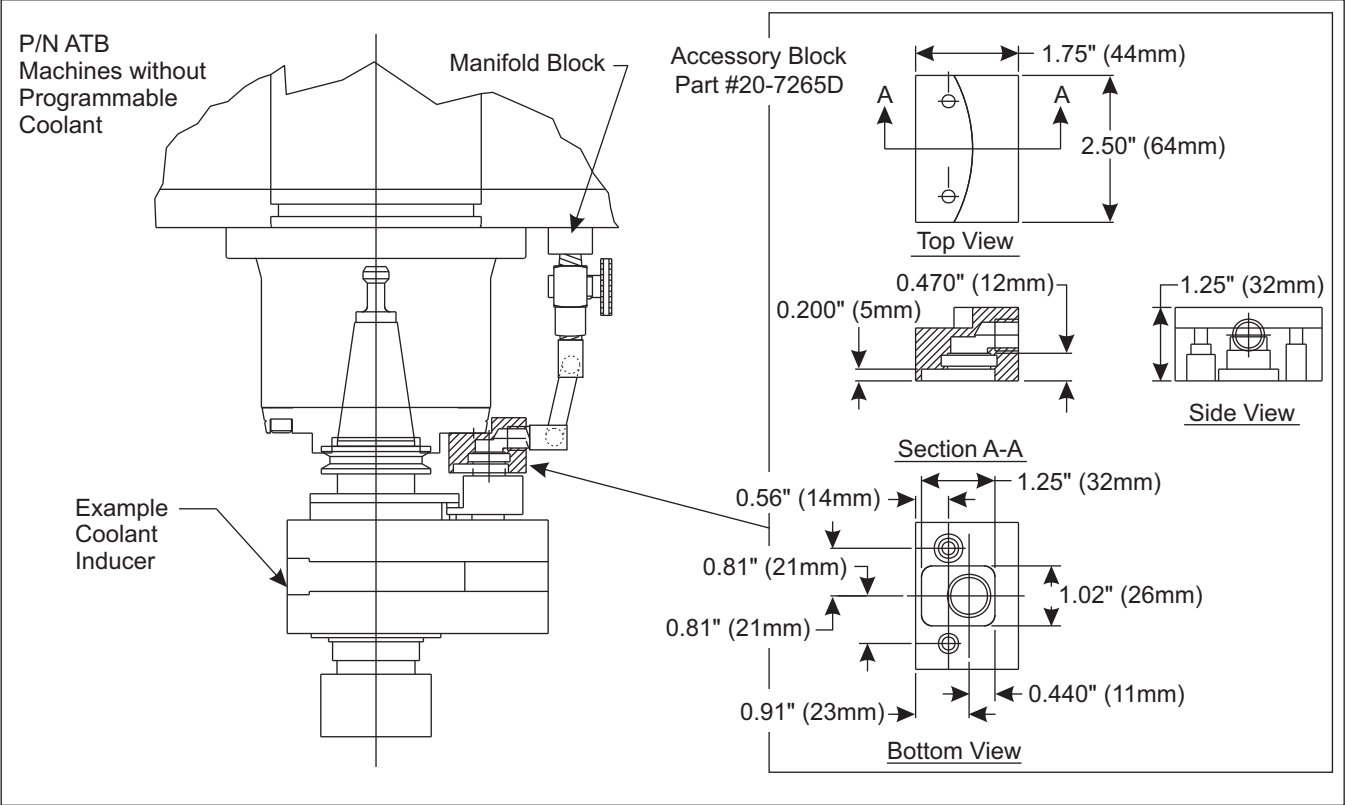

TOOLING BLOCK - 50TAPER

