

NOTES:
 G47 P1 ENGRAVES VALUE
 IN MACRO VARIABLE #599.
 INCREMENTS VARIABLE BY
 ONE EACH TIME G47 P1 IS RUN

%
 O01878 (ENGRAVE SN)
 (ENGRAVES SERIAL NUMBER AND TEXT)

M06 T8 (ENGRAVING TOOL)
 M03 S12000
 (ENGRAVE)
 G55 G00 G90 X-0.15 Y0.98
 G43 H08 Z0.1
 G01 Z0.1 F100.
 G187 P3

(ENGRAVE TEXT: S/N)
 G47 P0 (S/N) X-0.15 Y0.98 I324.22 J0.125 R.1 Z-.004 F80. E40.
 (ENGRAVE 4 DIGIT SERIAL NUMBER)
 G47 P1 (####) I-35.78 J0.125 R.1 Z-.004 F80. E40.

G00 G90 Z4.
 G53 G00 G90 Y0
 G187
 M30

O01879 (ENGRAVE S/N ####)
 (SERIAL NUMBER AND TEXT, ONE LINE)
 (MUST USE #S WITH G47 P1)

M06 T8
 M03 S12000
 (ENGRAVE)
 G55 G00 G90 X-0.15 Y0.98
 G43 H08 Z0.1
 G01 Z0.1 F100.
 G187 P3

(ENGRAVE 4 DIGIT SN, ONE LINE)
 G47 P1 (S/N ####) X-0.15 Y0.98 I324.22 J0.125 R0.1 Z-0.004 F80. E40.

G00 G90 Z4.
 G53 G00 G90 Y0
 G187
 M30
 %

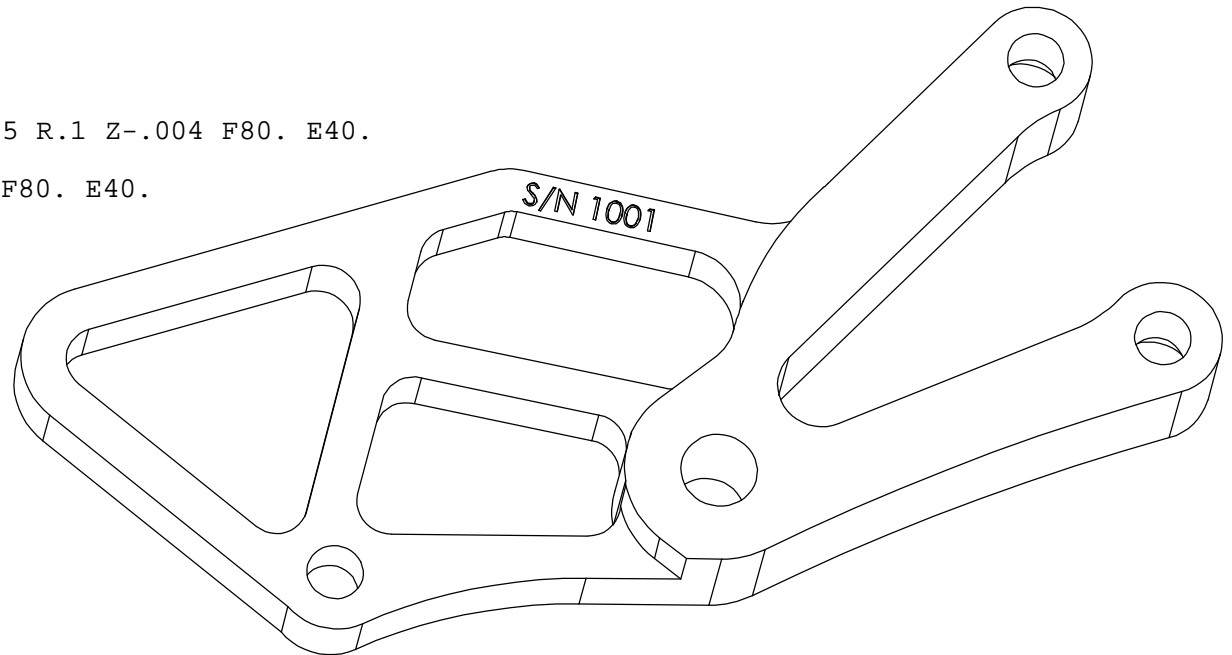

TITLE: G47 P1, SERIAL NUMBER ENGRAVING		
SIZE A	DWG. NO.	REV X1
SCALE: 1:2	WEIGHT:	